



BD DODGE CUMMINS 03-09
COOL-IT INTERCOOLER
Installation Instructions



Application List		
2003 - 2009	Dodge 24V	1042525



PLEASE READ ALL INSTRUCTIONS BEFORE INSTALLATION



UNLESS AN EO# IS LISTED, THIS PRODUCT IS LEGAL IN CALIFORNIA FOR RACING VEHICLES ONLY, WHICH MAY NEVER BE USED UPON A HIGHWAY.

KIT CONTENTS:

Please check to make sure that you have all the parts listed in this kit **before** you start the disassembly of your truck.

1402525	1402512	1405213
		
<i>Intercooler</i>	<i>Bolt</i>	<i>Washer</i>
Qty: 1	Qty: 2	Qty: 2

1405212	1405211	1453320
		
<i>3.5" Clamp</i>	<i>3" Clamp</i>	<i>Intercooler Boot</i>
Qty: 2	Qty: 2	Qty: 2

1100110	1100111	1100112
		
<i>1/4 x 3/4 Bolt</i>	<i>Flat Washer</i>	<i>Lock Washer</i>
Qty: 4	Qty: 4	Qty: 4

BD Engine Brake Inc.

Plant Address: 33541 MacLure Rd. Abbotsford, BC, Canada V2S 7W2

U.S. Shipping Address: 88-446 Harrison St, Sumas, WA 98295 U.S. Mailing Address: P.O. Box 231, Sumas, WA 98295

Phone: 604-853-6096 | Fax: 604-853-8749 | Internet: www.bd-power.com

Options

Description	Part #
Super B Turbo Kit 2003-04	1045230
Super B Turbo Kit 2004.5-2006	1045235
Twin Turbo Kit 2003-06	1045330

UNLESS AN EO# IS LISTED, THIS PRODUCT IS LEGAL IN CALIFORNIA FOR RACING VEHICLES ONLY, WHICH MAY NEVER BE USED UPON A HIGHWAY

Removal

Disconnect the battery negative cables.

Remove the plastic A/C line shield located on the passenger side of the A/C condenser.

Remove the four bolts securing the A/C condenser to the intercooler.

Once the four bolts are removed rotate the A/C condenser up and towards the passenger side of the vehicle. Be sure not to break or crack the A/C lines. Once the A/C condenser has been rotated 90°, secure the condenser to the vehicle's lifted hood by a coat hanger or steel wire.

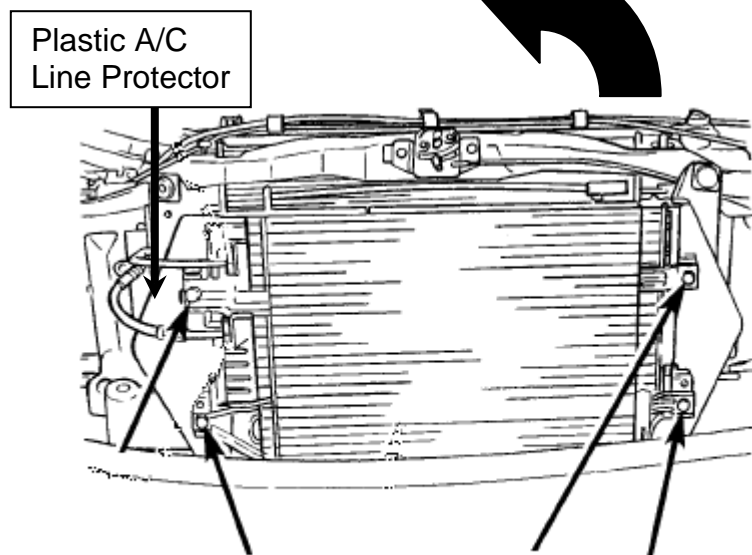

With A/C condenser rotated out of the way, you should be able to access the factory intercooler.

Remove the two bolts securing the top of the intercooler.

Loosen and remove the two intercooler boots and four clamps securing the intercooler to the intercooler tubes.

Pivot the intercooler forwards and then lift directly up to remove the intercooler.

BD Engine Brake Inc.

Plant Address: 33541 MacLure Rd. Abbotsford, BC, Canada V2S 7W2

U.S. Shipping Address: 88-446 Harrison St, Sumas, WA 98295 U.S. Mailing Address: P.O. Box 231, Sumas, WA 98295

Phone: 604-853-6096 | Fax: 604-853-8749 | Internet: www.bd-power.com

Installation

Remove the two upper rubber isolators from the stock intercooler and install them on the Cool-It intercooler.

Remove the two lower rubber U shaped isolators from the back of the stock intercooler and insert them into the U supports on the back of the Cool-It intercooler.

Loosely install the 3-3.5" intercooler boots on both intercooler tubes along with the 3.0" spring loaded hose clamps.

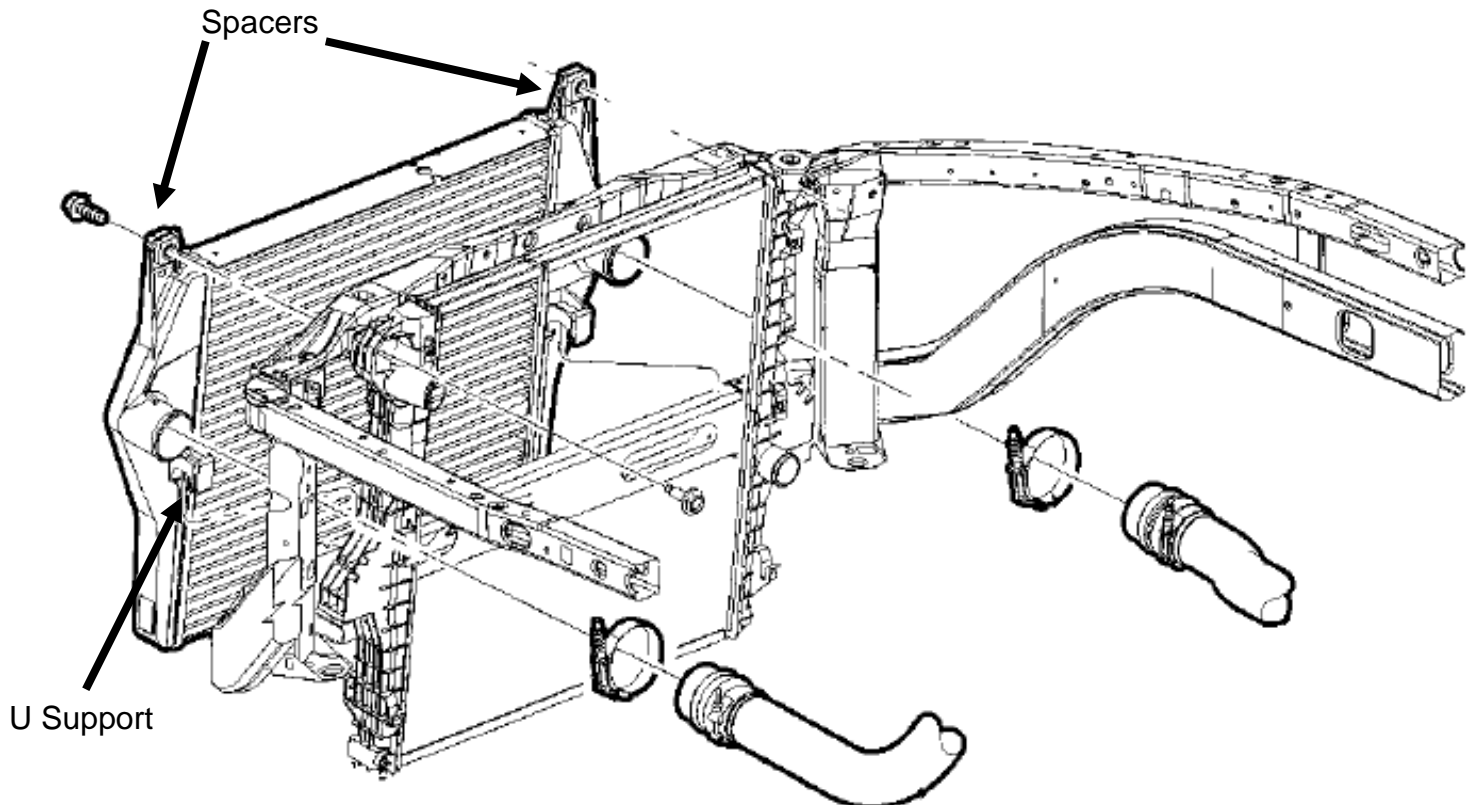

Carefully lift the Cool-It intercooler into place ensuring that the "U" supports on the rear of the intercooler sit squarely on the cross member. Also ensure that the "U" shaped rubber isolators have maintained their shaped and not folded during installation.

BD Engine Brake Inc.

Plant Address: 33541 MacLure Rd. Abbotsford, BC, Canada V2S 7W2

U.S. Shipping Address: 88-446 Harrison St, Sumas, WA 98295 U.S. Mailing Address: P.O. Box 231, Sumas, WA 98295

Phone: 604-853-6096 | Fax: 604-853-8749 | Internet: www.bd-power.com

2008 6.7L Installation Note

On 2008 6.7L vehicles you will notice that the factory silicone intercooler boots are permanently connected to the CAC inlet and outlet tubes. You will need to cut off the swedged pinch ring with a cut off wheel. Be sure not to damage the inlet and outlet pipe in the process.

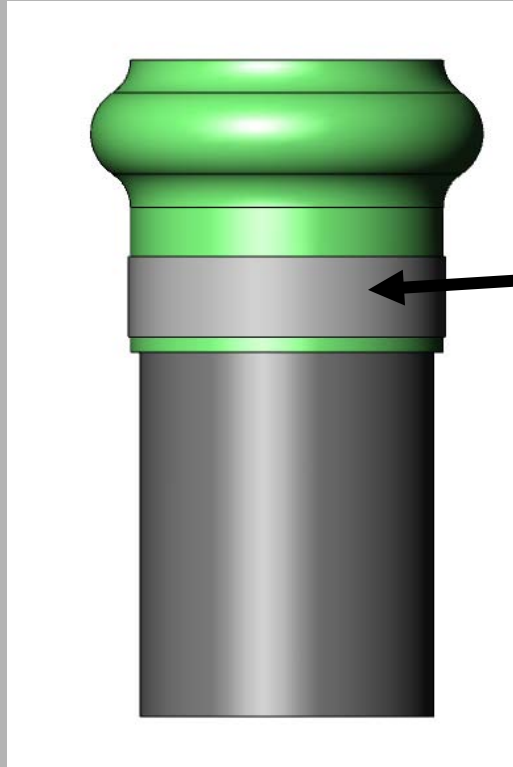

Cut swedged pinch ring to release silicone boot. Do not damage pipe in the process.

Once the pinch ring has been cut you can slide off the silicone boot and inserted the new provided silicone boot and clamp. **DO NOT OVER TIGHTEN NEW CLAMP.**

Center the intercooler and install the intercooler boots on both sides. Use the provided spring clamps to secure the boots to the pipes/intercooler. Note that the intercooler end takes have a diameter of 3.5" and will use the larger of the two spring clamps.

BD Engine Brake Inc.

Plant Address: 33541 MacLure Rd. Abbotsford, BC, Canada V2S 7W2

U.S. Shipping Address: 88-446 Harrison St, Sumas, WA 98295 U.S. Mailing Address: P.O. Box 231, Sumas, WA 98295

Phone: 604-853-6096 | Fax: 604-853-8749 | Internet: www.bd-power.com

You can now secure the top of the intercooler using the provided bolts, washers and spacers. Be sure to install the 2 factory rubber isolators onto the top of the intercooler.

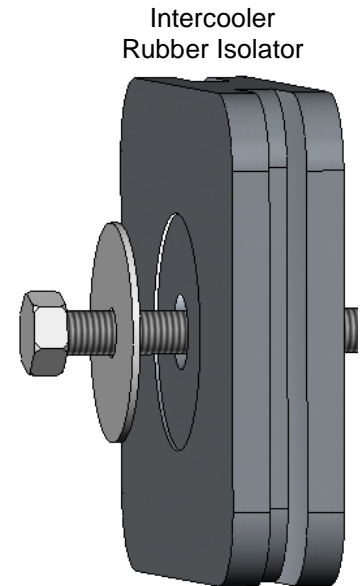

NOTE: SOME VEHICLES YOU WILL NEED TO CUT OFF THE ENDS OF THE 4 (2 ON EACH SIDE) BUMPER SUPPORT BRACKET BOLTS.

You can now release the A/C condenser and rotate it back into place. Again be very careful to discharge A/C gas.

The Cool-It intercooler has two different mounting arrangements that you can utilize depending on if you had a plastic factory intercooler or an aluminum one. Use the provided bolts and washers to secure A/C condenser in place.

Re-install the plastic A/C line shield.

Re-install battery cables.

You can now take the vehicle for a road test ensuring that there are no boost leaks. Once the road test is successful re-check all bolts.