



BD *TowLoc*

Transmission and Converter Control Strategy

Instruction Manual

1067500	Dodge	1994-2003
1067501	Dodge	2004
1067502	Dodge	2005
1067700	Ford	1995-2003

***** READ THIS MANUAL COMPLETELY BEFORE INSTALLING THIS PRODUCT *****

Installation Manual P/N#: 11067500

******* FORD INSTALLATION WARNING *******

IT IS POSSIBLE THAT THIS TOWLOC MAY NOT BE COMPATIBLE WITH YOUR POWERSTROKE TRUCK. PLEASE TURN TO PAGE 3 FOR ADDITIONAL INFORMATION.

BD Engine Brake Inc.

Plant Address: 33541 MacLure Rd. Abbotsford, BC, Canada V2S 7W2

U.S. Shipping Address: 88-446 Harrison St, Sumas, WA 98295 U.S. Mailing Address: P.O. Box 231, Sumas, WA 98295

Phone: 604-853-6096 | Fax: 604-853-8749 | Internet: www.bd-power.com

TABLE OF CONTENTS

Kit Contents	3
Welcome.....	3
Special Tools Required.....	3
TowLoc Notes.....	3
Ford Installation Warning	3
Programming Notes	4
Notes On Electrical Connectors	4
TowLoc Modes	5
TOWLOC INSTALLATION – DODGE.....	6
Wire Connections.....	8
1994-95 Dodge Pinouts	8
1996-03 Dodge Pinouts	8
2004 Dodge Pinouts	9
2005 Dodge Pinouts	9
TowLoc Wire Harness Pin Layouts	10
Wiring Schematic.....	11
Grey Wiring Harness Connections.....	12
Black Wiring Harness Connections.....	14
Toggle Switch Installation	17
TOWLOC INSTALLATION – FORD.....	18
Wire Harness Pin Layouts	19
Ford Engine Control Schematic	20
Gray Wiring Harness Connections.....	20
Black Wiring Harness Connections.....	22
Toggle Switch Installation	24
Wiring Schematic (With PressureLoc Installed)	25
Wiring Schematic (Without PressureLoc Installed).....	26
Programming the TowLoc.....	27
Configuring a PC Laptop with Hyper Terminal.....	27
Configuring a Palm Pilot.....	31
Programming Procedure	33
TPS Calibration.....	33
TowLoc Calibration	34
Menu Item Descriptions	37
Speed Calibration	39
Questions?.....	42
Troubleshooting	43

Kit Contents

1674510 (2003 Dodge) **or**
1674511 (2004 Dodge) **or**
1674512 (2005 Dodge) **or**
1674710 (Ford) - Control Module
1672000 - Switch Kit
1607150 - Black Plug Wiring Harness
1607160 - Gray Plug Wiring Harness
1607190 - Installation Kit

Welcome

Thank you for purchasing a BD Power TowLoc Transmission and Converter Control Strategy System. Your kit should have the above-mentioned items for your installation. This manual is divided into different sections to assist you with your installation and configuration of your kit. We strongly suggest that you read this manual completely before beginning installation.

Special Tools Required

- Drill with 1/16" bit or Unibit
- Crimping pliers
- Self-powered test light or multimeter
- Assorted screwdrivers
- PC laptop with a serial port, or a Palm OS handheld device
- Compatible 9-pin serial cable for laptop/palm.

➤ *Note: If your PC laptop does not have a serial port and has USB only, a USB->Serial adapter is available for purchase (P/N: 1607080)*

TowLoc Notes

- Module is weather resistant and mounted under the hood
- Programmable automatic 4th to 3rd downshift
- Automatically commands converter lock-up after disengagement without having to feather throttle
- Programmable speed to which exhaust brake will disengage
- Controls activation of PressureLoc
- Versatile switching options
- Programmable parameters can be set with laptop or Palm Pilot

Ford Installation Warning

** A small number of Ford Powerstrokes have no wire lead coming out from Pin 19 (Aux Tachometer Feed). If this is the case, the TowLoc is not compatible with the signal on these trucks.

BD Engine Brake Inc.

Plant Address: 33541 MacLure Rd. Abbotsford, BC, Canada V2S 7W2

U.S. Shipping Address: 88-446 Harrison St, Sumas, WA 98295 U.S. Mailing Address: P.O. Box 231, Sumas, WA 98295

Phone: 604-853-6096 | Fax: 604-853-8749 | Internet: www.bd-power.com

Programming Notes

The module you have received with this kit has been preprogrammed with **default** settings for either Dodge (1067500-2) or Ford (1067700) pick-ups. These settings have been put in place to allow for a basic installation where a laptop PC or Palm Pilot are not available and in most cases will probably be sufficient for the operation of the TowLoc.

It is recommended with each installation that the module be setup with a laptop PC or Palm Pilot.

There will be some instances where the TowLoc will not function properly due to the throttle position sensor (TPS/APPS) and/or vehicle speed sensor (VSS) not sending an output in the parameters the default settings are calibrated to. In these cases, the TowLoc module will have to be connected to a laptop PC or Palm Pilot so the module can be calibrated to match the TPS/APPS and/or VSS.

Some of the default settings for the different options are in place to give basic operation of the TowLoc, but may not give the function ability the customer is looking for. Therefore, a laptop PC or Palm Pilot must be connected to the TowLoc to change these options. (Settings are explained in the "**Programming the TowLoc**" section)

If the TowLoc is not operating correctly or not achieving the functions the customer is requiring, leave the TowLoc switch in the Stock Operation position or disconnect the power from the module until such time as the module can be connected to a laptop PC or Palm Pilot.

NOTE: The default speed settings are measured in miles per hour (MPH).

Notes On Electrical Connectors

Included in the installation kit are a number of gray and black electrical connectors ("Posi-Taps") that are to be used on various sized wires. The TowLoc kit harness wire is 20GA and most of the OEM wires are 20GA as well, which would require the use of the Red connectors.

OEM Wire	Posi-Tap™ Color
18-22ga	Gray or Red
12-18ga	Black
10-12ga	Green or Yellow

In some cases (i.e. 12v switch power source), some wires may be 14GA or 16GA and will require the use of the black Posi-Taps.

BD Engine Brake Inc.

Plant Address: 33541 MacLure Rd. Abbotsford, BC, Canada V2S 7W2

U.S. Shipping Address: 88-446 Harrison St, Sumas, WA 98295 U.S. Mailing Address: P.O. Box 231, Sumas, WA 98295

Phone: 604-853-6096 | Fax: 604-853-8749 | Internet: www.bd-power.com

Using of the wrong sized connector may result in a poor connection or wires being broken. The supplied connectors should be sufficient for most installations. If more connectors are required they are available from most automotive parts stores.

BD recommends soldering the wires and covering the connections with heat shrink, which will give the best connection possible. Care must be taken when soldering wires that are connected to PCM and other sensitive items.

NOTE: Always check the connections with a self-powered test light or multimeter to confirm good continuity.

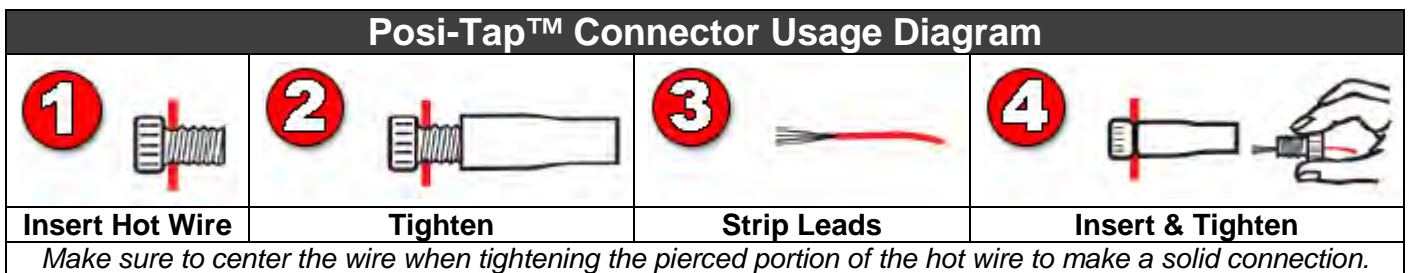

TowLoc Modes

The lighted toggle switch kit that currently comes in the kit allows for a combination of 3 of the following modes:

1067500-2 or 1067700						
Mode	Switch Pos.	Color	Or	Mode	Switch Pos.	Color
TorqLoc	Up	Red		TorqLoc	Up	Red
Stock	Middle	None		AutoLoc	Middle	White
AutoLoc	Down	Green		UnLoc	Down	Green

<u>AutoLoc</u>	Engages clutch lock-up and brake on deceleration until RPM and/or speed has dropped below set parameters
<u>TorqLoc</u>	Commands clutch lock-up
<u>UnLoc</u>	Prevents clutch lock-up
<u>Stock</u>	Operation of clutch lock-up, transmission circuit, and exhaust brake are turned off

TOWLOC INSTALLATION – DODGE

- 1) Identify all the parts in the kit to confirm that you have the correct kit for your application.
- 2) Locate a position to mount the TowLoc module – a likely spot is the firewall, just in front of the driver. Drill a hole with a 1/16" drill bit.
- 3) The grounding screw located on the firewall (as shown in diagram to the right) can be used to attach the ground connections.
- 4) On 2003+ Dodges, there is no room on the driver's side firewall, so a likely place to mount the TowLoc module is on the top of the Power Distribution Box (fuse/relay box). Use Velcro strips or two-sided tape to mount the module.
- 5) Disconnect both negative battery cables from the batteries.
- 6) Remove the air cleaner assembly. **This step is not necessary on 2003-2004 model year Dodges.**

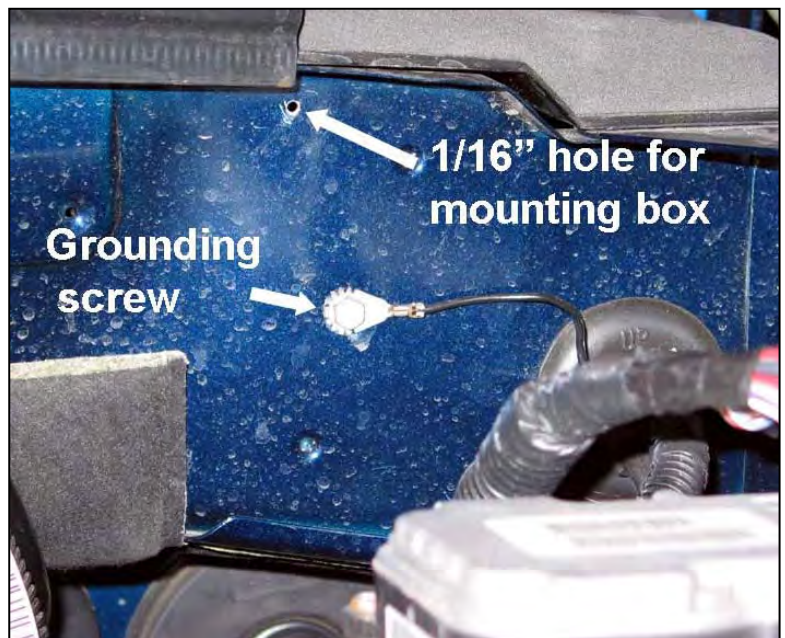

HINT: If you wish you can make a note of the radio stations set in memory so you can reprogram the radio when the batteries are hooked back up.

BD Engine Brake Inc.

Plant Address: 33541 MacLure Rd. Abbotsford, BC, Canada V2S 7W2

U.S. Shipping Address: 88-446 Harrison St, Sumas, WA 98295 U.S. Mailing Address: P.O. Box 231, Sumas, WA 98295

Phone: 604-853-6096 | Fax: 604-853-8749 | Internet: www.bd-power.com

7) Locate the PCM connectors and identify them as C3, C2, and C1 as seen in the photo to the right.



On 2003 Dodge's, the PCM is mounted vertically on the firewall so the connectors will be (from top to bottom):

- C3** – top
- C2** – middle
- C1** – bottom

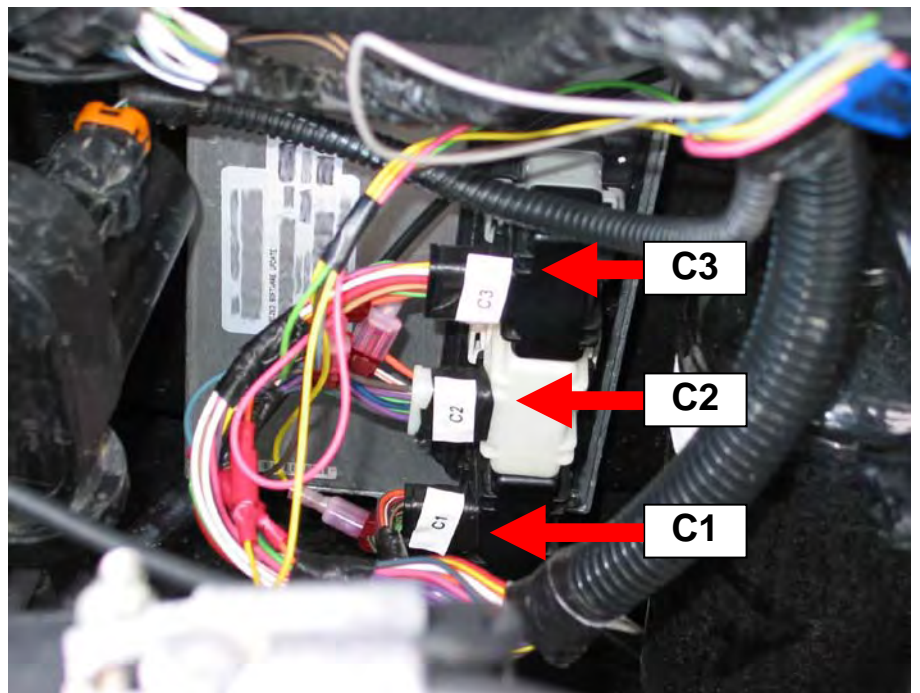

NOTE: On 2004-up Dodge's there is no PCM, so hook-ups must be done at the ECM located on the driver side of the engine block. There are 2 connectors - a 60-pin (C1) and a 50-pin (C2) connector.

8) Check the following wiring harness pin-out diagrams and start by separating the wire to go into the cab, and the wires to go over to the PCM/ECM.

**** IMPORTANT: THE FOLLOWING WIRING DIAGRAMS AND HOOK UP INSTRUCTIONS SHOULD BE CORRECT FOR MOST MODELS BUT TO ENSURE ACCURACY YOU SHOULD CHECK WITH THE PROPER TECHNICAL MANUAL FOR YOUR SPECIFIC MODEL TRUCK. ****

Wire Connections

1994-95 Dodge Pinouts

<p>VIEWED FROM TERMINAL END</p>	Pin	Wire Color	Function
	10	OR/WT	Overdrive Switch Sensor
	22	OR/DB	Throttle Position Sensor
	43	GY/LB	Crankshaft Position Sensor
	47	WT/OR	Vehicle Speed Sensor
	54	OR/BK	Torque Converter L/U Ctrl
55	BR	3-4 Shift Solenoid	

1996-03 Dodge Pinouts

	POWERTRAIN CONTROL MODULE (C1)		
	Pin	Wire	Function
	8	GY/BK	Crankshaft Position Sensor Signal
	23	OR/DB	Accelerator Pedal Position Sensor Signal

	POWERTRAIN CONTROL MODULE (C2)		
	Pin	Wire	Function
	11	OR/BK	Torque Converter Clutch Solenoid Control
	21	BR	3-4 Shift Solenoid Control
27	WT/OR	Vehicle Speed Sensor Signal	

	POWERTRAIN CONTROL MODULE (C3)		
	Pin	Wire	Function
	13	OR/WT	Overdrive Off Switch Sensor

2004 Dodge Pinouts

ENGINE CONTROL MODULE (C1)		
Pin	Wire	Function
11	TN/BK	ECT Signal
14	BR/WT	TP Signal
24	DB/GY	CMP Signal

ENGINE CONTROL MODULE (C2)		
Pin	Wire	Function
11	DG/YL	VSS Sensor Signal #1
13	DG	Tow/Haul Mode Switch
15	DG/TN	3-4 Solenoid Ctrl
25	YL/LB	Torque Converter Clutch Solenoid Ctrl

2005 Dodge Pinouts

ENGINE CONTROL MODULE (C1)		
Pin	Wire	Function
11	TN/BK	ECT Signal
18	BR/WT	APPS Signal
24	DB/GR	CMP Signal

ENGINE CONTROL MODULE (C2)		
Pin	Wire	Function
11	DG/YL	VSS Sensor Signal #1
13	DG	Tow/Haul Mode Switch
15	DG/TN	3-4 Solenoid Ctrl
24	DB/GR	Cruise Control
25	YL/LB	Torque Converter Clutch Solenoid Ctrl
46	VT	Cruise Control

BD Engine Brake Inc.

Plant Address: 33541 MacLure Rd. Abbotsford, BC, Canada V2S 7W2

U.S. Shipping Address: 88-446 Harrison St, Sumas, WA 98295 U.S. Mailing Address: P.O. Box 231, Sumas, WA 98295

Phone: 604-853-6096 | Fax: 604-853-8749 | Internet: www.bd-power.com

TowLoc Wire Harness Pin Layouts

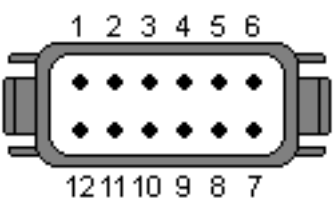
BLACK PLUG				
	1	Switch Module Green	7	Cruise I/O
	2	Switch Module Yellow	8	Shift I/O
	3	PressureLoc Output	9	TCC Input from PCM
	4	TCC Output	10	Brake Spool Valve Output
	5	Shift I/O	11	Switch Module (Black)
	6	Cruise I/O	12	Switch Module (Red)

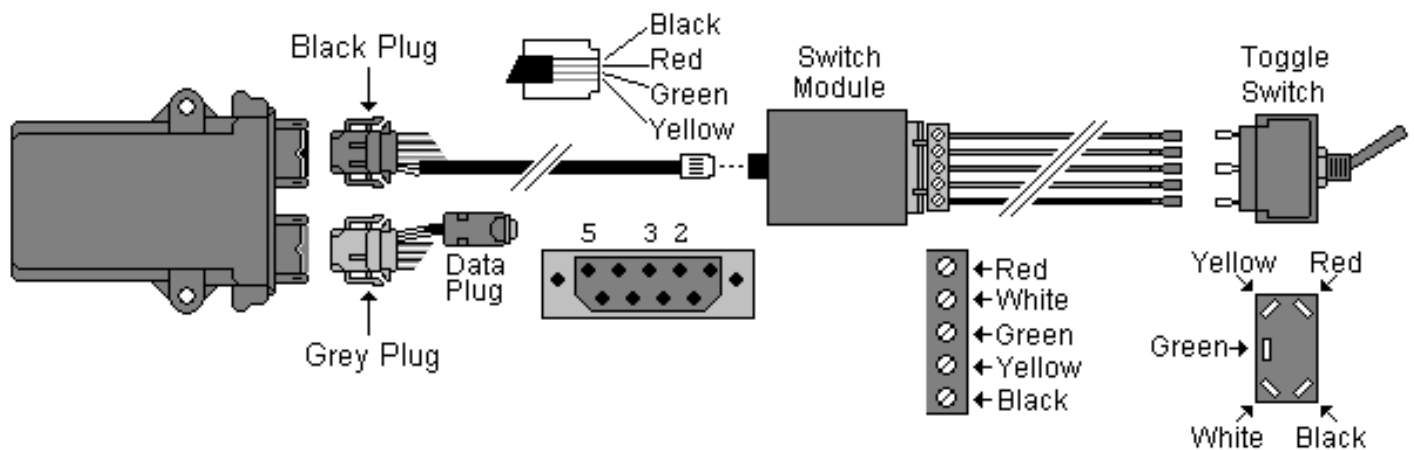

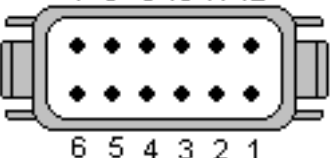
GRAY PLUG				
	1	12V Power	7	RPM Input
	2	Ground	8	TPS Input
	3	No Connection	9	Water Temp Input
	4	Shift Solenoid	10	Data Plug Pin 3
	5	Shift Sol 2 (Ford)	11	Data Plug Pin 2
	6	VSS Input	12	Data Plug Pin 5

Wiring Schematic

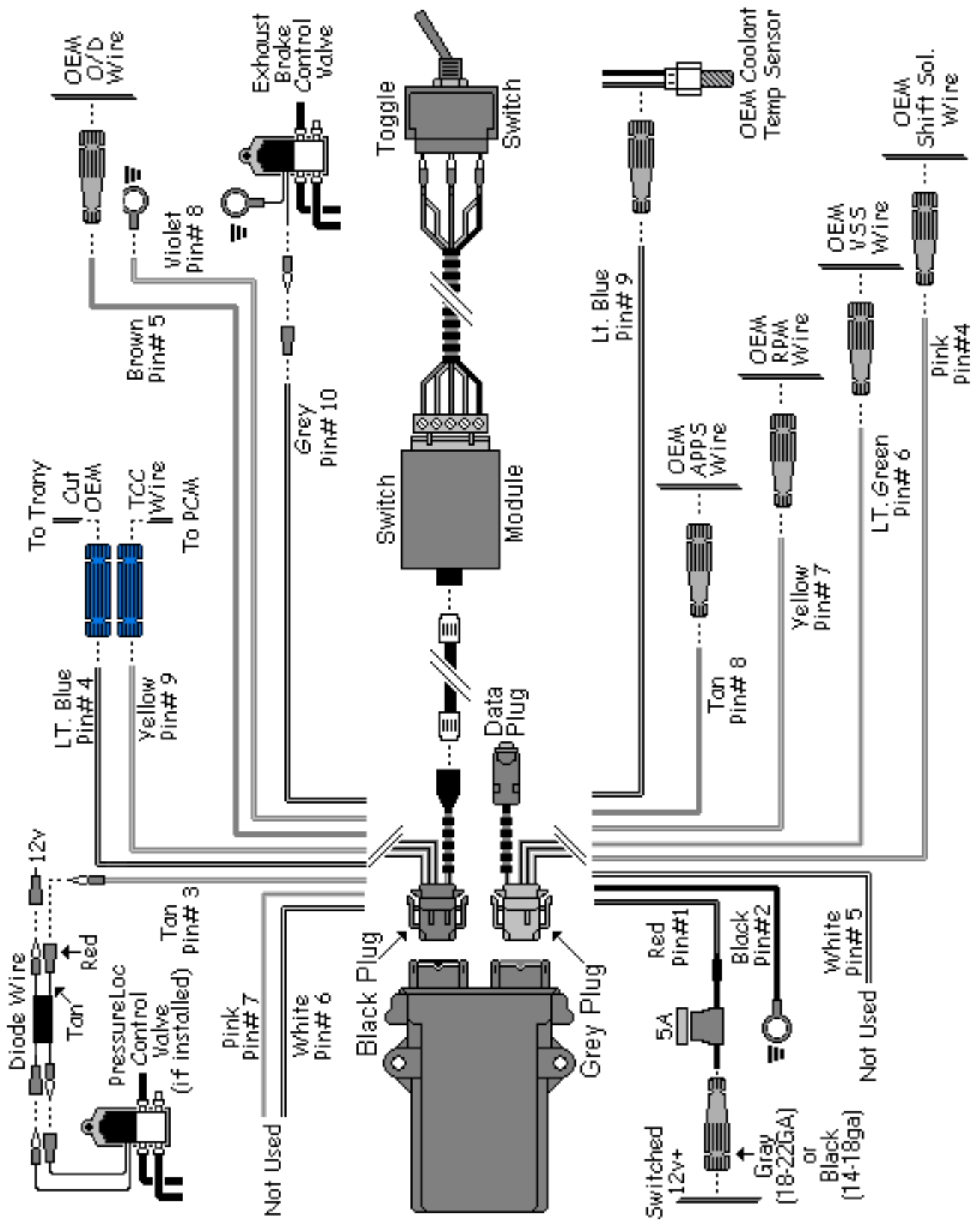

BD Engine Brake Inc.

Plant Address: 33541 MacLure Rd. Abbotsford, BC, Canada V2S 7W2

U.S. Shipping Address: 88-446 Harrison St, Sumas, WA 98295 U.S. Mailing Address: P.O. Box 231, Sumas, WA 98295

Phone: 604-853-6096 | Fax: 604-853-8749 | Internet: www.bd-power.com

Grey Wiring Harness Connections

Lay the wires out from the grey plug harness for hook up. Leave enough slack to allow for attaching and removing the Gray plug from the control module when the module is mounted. **NOTE:** DO NOT secure the control module yet. For more details see the wiring charts on page 10.

Pin	Function	Wire Color	Instructions												
1	12V Switched Power	Red	Pass through the firewall and under the steering column by piercing the rubber grommet below the master cylinder and connect to a 12V switched power source.												
2	Ground	Black	Install on the ground screw behind the TowLoc control box or a good vehicle ground.												
3	N/C	N/C	N/C												
4	Shift Solenoid 1	Pink	Connect with a Posi-Tap at the "3-4 Solenoid Control" wire.												
<table border="1"> <thead> <tr> <th>Year</th> <th>Location</th> <th>Color Wire</th> </tr> </thead> <tbody> <tr> <td>1994-95</td> <td>JTEC Pin 55</td> <td>Brown</td> </tr> <tr> <td>1996-03</td> <td>PCM C2 Pin 21</td> <td>Brown</td> </tr> <tr> <td>2004-05</td> <td>ECM C2 Pin 15</td> <td>Dark Green/ Tan</td> </tr> </tbody> </table>				Year	Location	Color Wire	1994-95	JTEC Pin 55	Brown	1996-03	PCM C2 Pin 21	Brown	2004-05	ECM C2 Pin 15	Dark Green/ Tan
Year	Location	Color Wire													
1994-95	JTEC Pin 55	Brown													
1996-03	PCM C2 Pin 21	Brown													
2004-05	ECM C2 Pin 15	Dark Green/ Tan													
5	Shift Solenoid 2	White	For Ford installations only.												
6	VSS Input	Green	Connect with a Posi-Tap at "Vehicle Speed Sensor Signal" wire.												
<table border="1"> <thead> <tr> <th>Year</th> <th>Location</th> <th>Color Wire</th> </tr> </thead> <tbody> <tr> <td>1994-95</td> <td>JTEC Pin 47</td> <td>White/Orange</td> </tr> <tr> <td>1996-03</td> <td>PCM C2 Pin 27</td> <td>White/Orange</td> </tr> <tr> <td>2004-05</td> <td>ECM C2 Pin 11</td> <td>Dark Green/Yellow</td> </tr> </tbody> </table>				Year	Location	Color Wire	1994-95	JTEC Pin 47	White/Orange	1996-03	PCM C2 Pin 27	White/Orange	2004-05	ECM C2 Pin 11	Dark Green/Yellow
Year	Location	Color Wire													
1994-95	JTEC Pin 47	White/Orange													
1996-03	PCM C2 Pin 27	White/Orange													
2004-05	ECM C2 Pin 11	Dark Green/Yellow													
7	RPM Input	Yellow	Connect with a Posi-Tap at the "Camshaft Position (CMP)" (1994-2003) or Crankshaft Position Sensor (CKP)" (2004+) signal wire.												
<table border="1"> <thead> <tr> <th>Year</th> <th>Location</th> <th>Color Wire</th> </tr> </thead> <tbody> <tr> <td>1994-95</td> <td>JTEC Pin 43 CMP</td> <td>Grey/Light Blue</td> </tr> <tr> <td>1996-03</td> <td>PCM C1 Pin 8 CMP</td> <td>Grey/Black</td> </tr> <tr> <td>2004-05</td> <td>ECM C1 Pin 24 CKP</td> <td>Dark Blue/Grey</td> </tr> </tbody> </table>				Year	Location	Color Wire	1994-95	JTEC Pin 43 CMP	Grey/Light Blue	1996-03	PCM C1 Pin 8 CMP	Grey/Black	2004-05	ECM C1 Pin 24 CKP	Dark Blue/Grey
Year	Location	Color Wire													
1994-95	JTEC Pin 43 CMP	Grey/Light Blue													
1996-03	PCM C1 Pin 8 CMP	Grey/Black													
2004-05	ECM C1 Pin 24 CKP	Dark Blue/Grey													
8	TPS Input	Tan	Connect with a Posi-Tap at the "Accelerator Pedal Position Sensor (TP)" wire.												
<table border="1"> <thead> <tr> <th>Year</th> <th>Location</th> <th>Color Wire</th> </tr> </thead> <tbody> <tr> <td>1994-95</td> <td>JTEC Pin 22</td> <td>Orange/Dark Blue</td> </tr> <tr> <td>1996-03</td> <td>PCM C1 Pin 23</td> <td>Orange/Dark Blue</td> </tr> </tbody> </table>				Year	Location	Color Wire	1994-95	JTEC Pin 22	Orange/Dark Blue	1996-03	PCM C1 Pin 23	Orange/Dark Blue			
Year	Location	Color Wire													
1994-95	JTEC Pin 22	Orange/Dark Blue													
1996-03	PCM C1 Pin 23	Orange/Dark Blue													

BD Engine Brake Inc.

Plant Address: 33541 MacLure Rd. Abbotsford, BC, Canada V2S 7W2

U.S. Shipping Address: 88-446 Harrison St, Sumas, WA 98295 U.S. Mailing Address: P.O. Box 231, Sumas, WA 98295

Phone: 604-853-6096 | Fax: 604-853-8749 | Internet: www.bd-power.com

		2004	ECM C1 Pin 14	Brown/White
		2005	ECM C1 Pin 18	Brown/White
9	Water Temp Input		Blue	<p>Connect with a Posi-Tap at the “Engine Coolant Temp Sensor” located by the thermostat housing on the front of the engine on the Tan w/ black tracer wire. On 12 Valve Dodges (1994-1998), ground this wire with pin 2 (ground) on the grey wiring harness.</p> <p>2004 & 2005 Dodges can connect to Pin 11 of C1 (ECT Signal).</p>

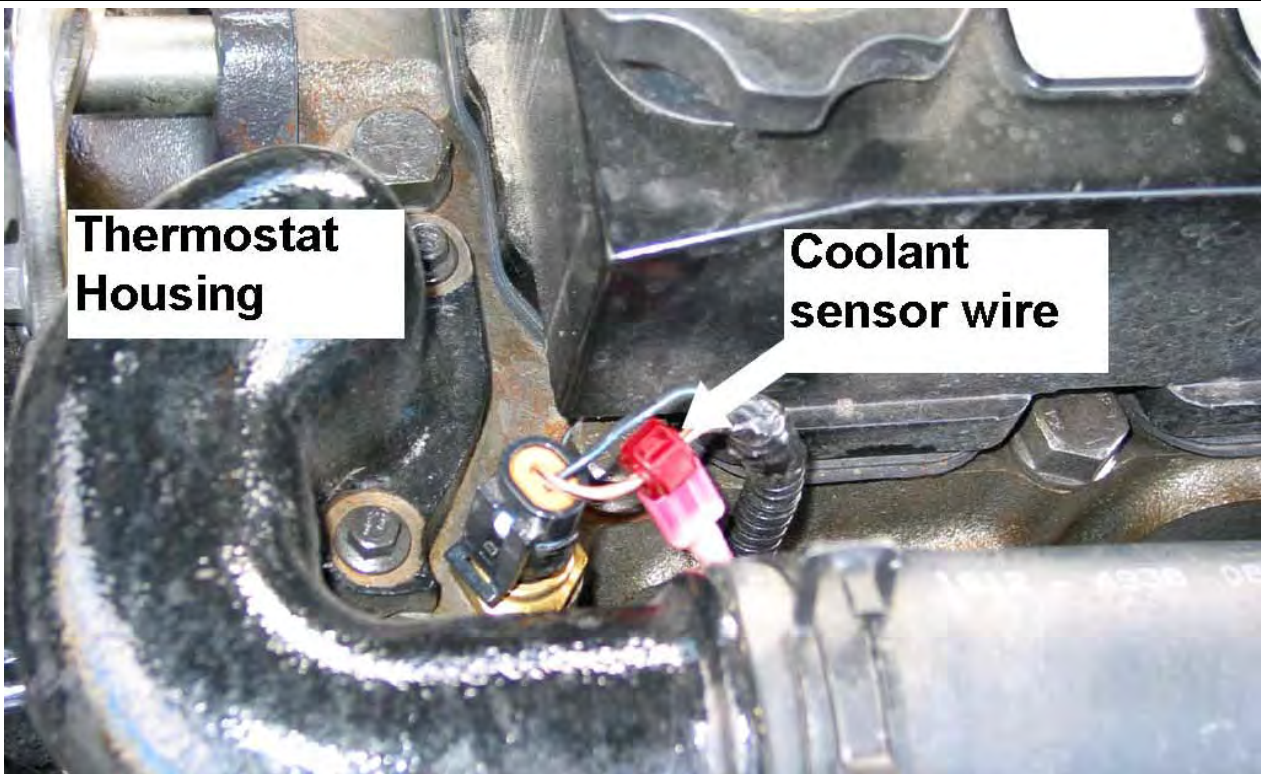

10	Data Plug		Serial Connector for setup.
11	Data Plug		Serial Connector for setup.
12	Data Plug		Serial Connector for setup.

Black Wiring Harness Connections

Lay out the wires for hook up from the black plug harness. Leave enough slack to allow for attaching and removing the Black plug from the control module when the module is mounted. **NOTE: DO NOT** secure the control module just yet.

Pin	Function	Towloc Wire Color	Instructions
1	Switch Module	Green	Pass the telephone style wire through the firewall and under the steering column by piercing the rubber grommet below the master cylinder. Plug one end into the connector by the main black plug and plug the other end into the switch control box.
2	Switch Module	Yellow	
11	Switch Module	Black	
12	Switch Module	Red	
3	PressureLoc Output (if equipped)	Tan	Connect the tan wire to the PressureLoc spool valve using the supplied diode wiring harness. (Remove the 4 wire signal modifier if the PressureLoc was previously installed).

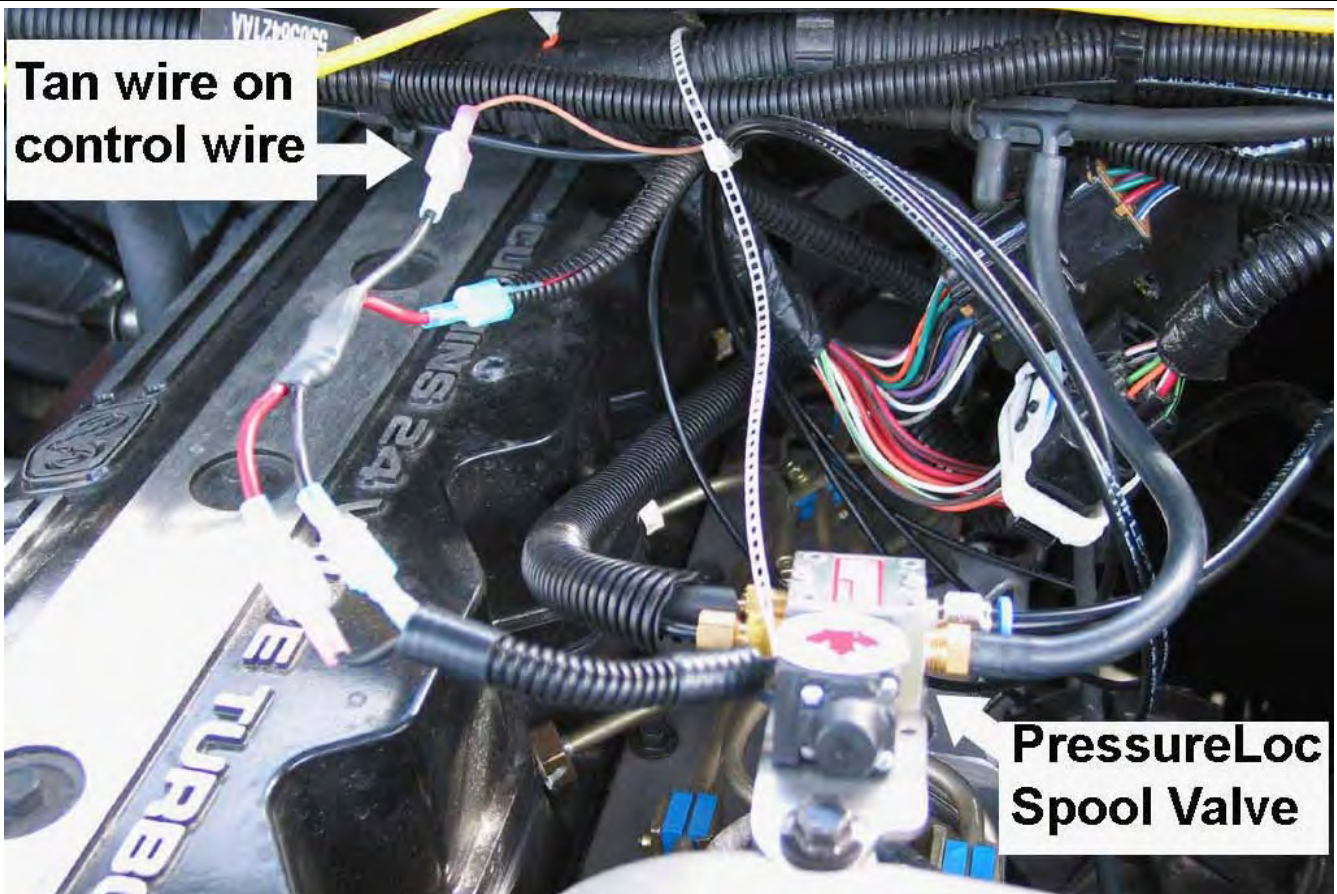

Locate the “Torque Converter Clutch Solenoid Control” wire. Refer to the table below for application, location and wire color for your model of truck.

Year	Location	Color Wire
1994-95	JTEC Pin 54	Orange/Black

BD Engine Brake Inc.

Plant Address: 33541 MacLure Rd. Abbotsford, BC, Canada V2S 7W2

U.S. Shipping Address: 88-446 Harrison St, Sumas, WA 98295 U.S. Mailing Address: P.O. Box 231, Sumas, WA 98295

Phone: 604-853-6096 | Fax: 604-853-8749 | Internet: www.bd-power.com

1996-03	PCM C2 Pin 11	Orange/Black
2004-05	ECM C2 Pin 25	Yellow/Light Blue

You will have to cut this wire about 4-6" from the connector. This will allow a good length of wire to work with.

4	TCC Output to Transmission	Blue	Connect with a blue Posi-Lock connector to the cut end of the "Torque Converter Clutch Solenoid Control" wire that goes to the transmission. See picture on next page.
9	TCC Input from PCM	Yellow	Connect with a blue Posi-Lock connector to the "Torque Converter Clutch Solenoid Control" wire that goes to the PCM (2003) or ECM (2004-05). See picture on next page.

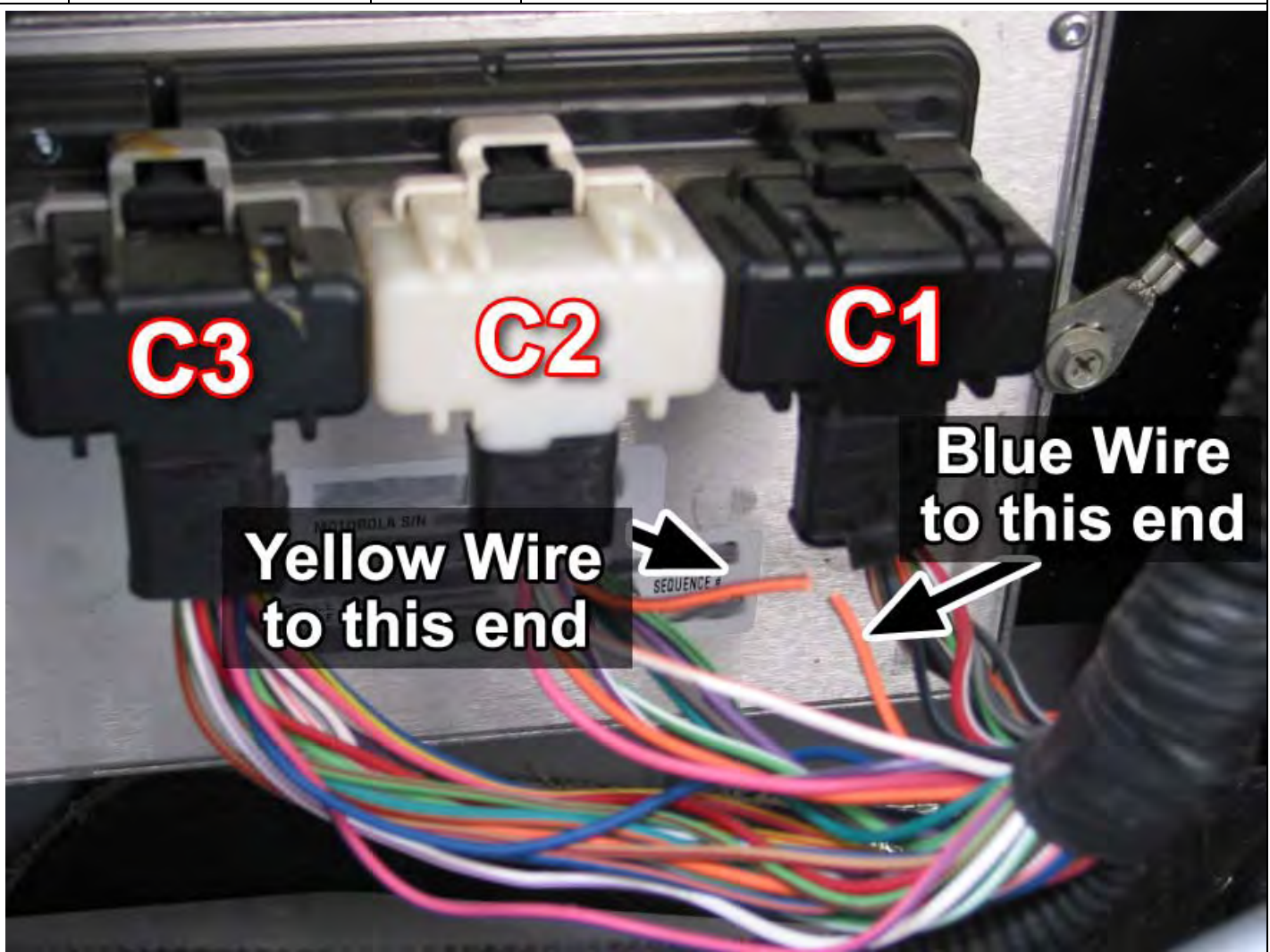

5	Overdrive In/Out	Brown	Connect with a Posi-Tap to the "Overdrive Off Switch Sense" wire.
---	-------------------------	--------------	---

Year	Location	Color Wire
1994-95	JTEC Pin 10	Orange/White
1996-03	PCM C3 Pin 13	Orange/White
2004-05	ECM C2 Pin 13	Dark Green

BD Engine Brake Inc.

Plant Address: 33541 MacLure Rd. Abbotsford, BC, Canada V2S 7W2

U.S. Shipping Address: 88-446 Harrison St, Sumas, WA 98295 U.S. Mailing Address: P.O. Box 231, Sumas, WA 98295

Phone: 604-853-6096 | Fax: 604-853-8749 | Internet: www.bd-power.com

On 2005 trucks, the automatic downshift feature needs to be disabled, however the connection must still be made.

6	Cruise In/Out	White	2005 Dodge ONLY. Connect the white wire to the ECM C2 Pin 46 Violet wire.
7	Cruise In/Out	Pink	2005 Dodge ONLY. Connect the pink wire to the ECM C2 Pin 24 Dark blue/dark green wire.
8	Shift In/Out	Violet	Connect to a good ground such as the ground screw behind the TowLoc control box mounting location. Refer to the picture on the next page for location.



Ground screw behind module

10	Exhaust Brake Control Valve	Gray	Connect to the power feed wire from the control valve of the exhaust brake.
----	------------------------------------	-------------	---

Attach the TowLoc control module to the firewall using the #8 sheet metal screw (supplied). **Do not over-tighten screw or the case will break.**

Plug in the Black Connector and Gray Connector to the TowLoc control module and clean up the install by Tie wrapping the wiring in place away from hot or moving components. **CAUTION:** When plugging and unplugging these connectors, handle by the connector and not the wires or the wires may break.

Toggle Switch Installation

NOTE: If an exhaust brake is previously installed, you cannot use the existing switch. You must use the provided TowLoc switch, although you can use the switch location.

- 1) Locate a convenient spot for the Toggle Switch on the dash or kick panel. Drill a pilot hole with a 1/8" drill bit and then finish drilling the hole with a 1/2" drill bit.
- 2) Mount the switch in the hole, making sure that the notch in the neck of the switch is facing down. Secure with the lock ring. This will align the switch so that when it is in the "UP" position, the light on the end of the switch is red, and when it is in the "DOWN" position, the light is green.
- 3) Ensure the telephone-style cable is plugged into the switch module and that the green connector that holds the wires is attached the module securely.
- 4) Secure the switch module and any loose wires up under the dash and replace any panels or dash components previously removed.
- 5) Re-connect all battery connections.

The installation for DODGE VEHICLES is now complete. Please proceed directly to the '**PROGRAMMING THE TOWLOC**' section.

Note: For non-ECM controlled PacBrake exhaust brakes. You can connect the brake in the same manner as a BD brake. For ECM controlled Pac Brakes, you need to remove the black wire from Pin 85 on the relay. This wire will need to be connected to the gray wire on the TowLoc.

TOWLOC INSTALLATION - FORD

1) Identify all the parts in the kit to confirm that you have the correct kit for your application.

2) Locate a position to mount the TowLoc control module. A recommended spot is the firewall, just in front of the driver.

3) Position the TowLoc control module in place and mark a spot to drill a hole for the mounting screw.

4) Drill a hole with a 1/16" drill bit.

5) Locate the grounding screw on the firewall as you will be attaching the ground connections to this screw.

6) Disconnect both negative battery cables from the batteries. If you choose, you can make note of the radio stations set in memory so that you can reprogram the radio when the batteries are hooked back up.

7) Locate the PCM connector inside the engine compartment on the drivers side firewall (see picture to the right).

8) Check the wiring harness pin-out diagrams on the following pages and then start by separating the wires to go into the cab and wires to the PCM.



BD Engine Brake Inc.

Plant Address: 33541 MacLure Rd. Abbotsford, BC, Canada V2S 7W2

U.S. Shipping Address: 88-446 Harrison St, Sumas, WA 98295 U.S. Mailing Address: P.O. Box 231, Sumas, WA 98295

Phone: 604-853-6096 | Fax: 604-853-8749 | Internet: www.bd-power.com

**** IMPORTANT: THE FOLLOWING WIRING DIAGRAMS AND HOOK UP INSTRUCTIONS SHOULD BE CORRECT FOR MOST MODELS BUT TO ENSURE ACCURACY YOU SHOULD CHECK WITH THE PROPER TECHNICAL MANUAL FOR YOUR SPECIFIC MODEL TRUCK. ****

Wire Harness Pin Layouts

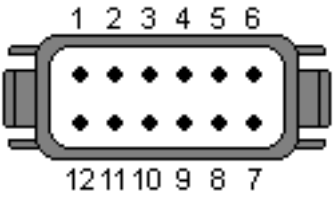
BLACK PLUG				
	1	Switch Module Green	7	Cruise I/O
	2	Switch Module Yellow	8	Shift I/O
	3	PressureLoc Output	9	TCC Input from PCM
	4	TCC Output	10	Brake Spool Valve Output
	5	Shift I/O	11	Switch Module (Black)
	6	Cruise I/O	12	Switch Module (Red)

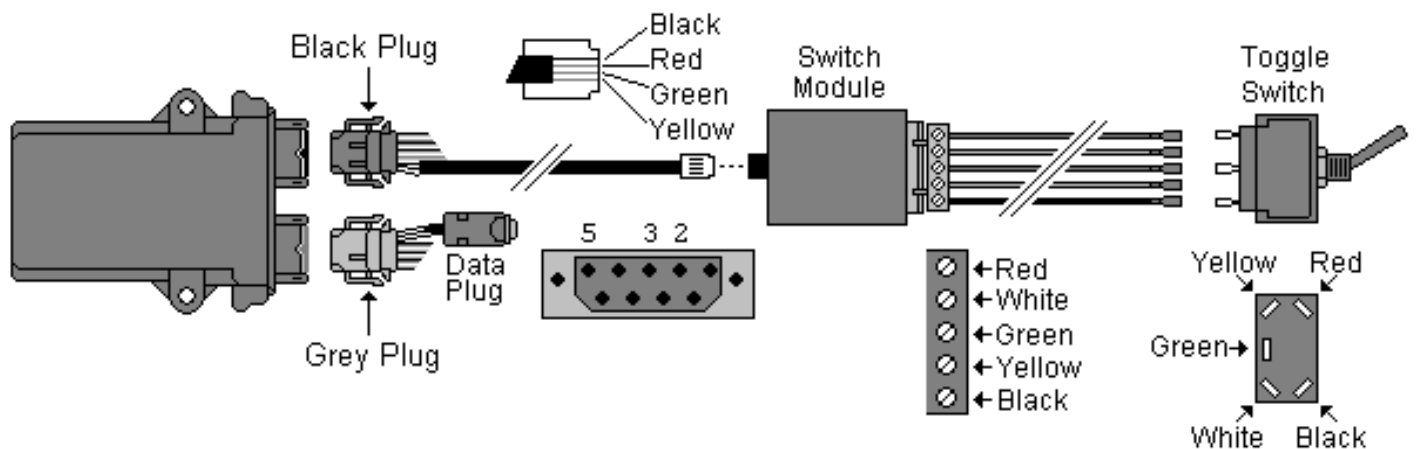

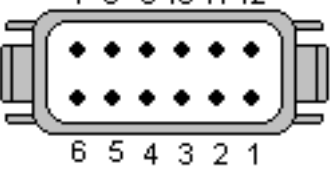
GRAY PLUG				
	1	12V Power	7	RPM Input
	2	Ground	8	TPS Input
	3	No Connection	9	Water Temp Input
	4	Shift Solenoid	10	Data Plug Pin 3
	5	Shift Sol 2 (Ford)	11	Data Plug Pin 2
	6	VSS Input	12	Data Plug Pin 5

Ford Engine Control Schematic

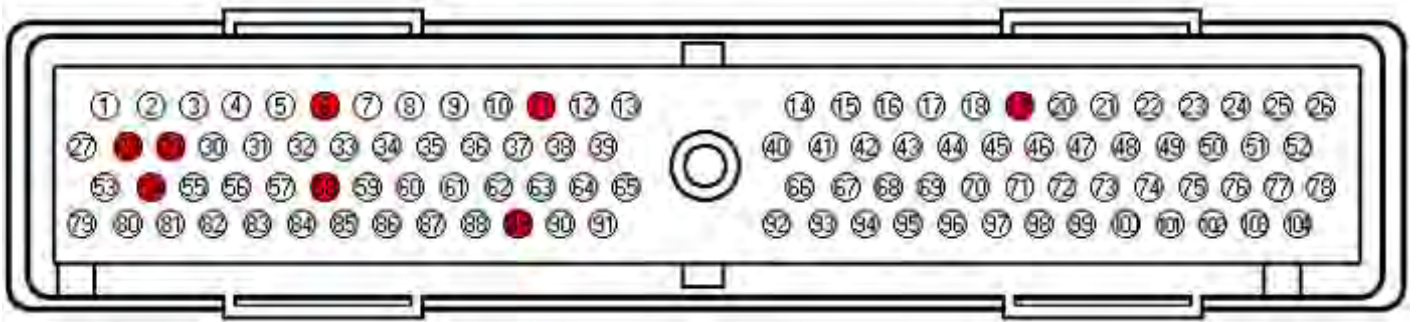

Pin	Circuit	OEM Wire	Function
6	237	OR/YL	Shift Solenoid #1
11	315	VT/OR	Shift Solenoid #2
19	648	WT/PK or DG/WT (2002-03)	Auxiliary Tachometer Feed **
28	643	RD	Water In Fuel Indicator (1994-1997 Models)
29	224	TN/WT	Transmission Overdrive Cancel Switch
54	480	VT/YL	Torque Converter Clutch Solenoid (1999-03 Models)
58	679	GR/BK	Vehicle Speed Sensor
89	355	GY/WT	Accelerator Pedal Position (APP)

** Some trucks have no lead coming out from Pin 19 (Aux Tach Feed). If this is the case, the TowLoc is not compatible with the signal on these trucks.

Gray Wiring Harness Connections

Identify and separate the wiring harness with the Gray Plug from the TowLoc kit and lay out the wires for hook up. Leave enough slack to allow to attach and remove the Gray plug from the control module when the module is mounted. **NOTE: DO NOT** secure the control module just yet.

Pin	Function	Towloc Wire Color	Instructions
1	12V Switched Power	Red	Pass through the firewall and under the steering column by piercing the rubber grommet on the drivers side firewall and connect to a 12V switched power source with a Posi-Tap.
2	Ground	Black	Install on the ground screw behind the TowLoc control box or a good vehicle ground.
3	N/C	N/C	N/C
4	Shift Solenoid 1	Pink	Connect with a Posi-Tap to the orange w/yellow tracer wire located at Pin 6 of the PCM Connector.

BD Engine Brake Inc.

Plant Address: 33541 MacLure Rd. Abbotsford, BC, Canada V2S 7W2

U.S. Shipping Address: 88-446 Harrison St, Sumas, WA 98295 U.S. Mailing Address: P.O. Box 231, Sumas, WA 98295

Phone: 604-853-6096 | Fax: 604-853-8749 | Internet: www.bd-power.com

5	Shift Solenoid 2	White	Connect with a Posi-Tap to the purple w/ orange tracer wire located at Pin 11 of the PCM Connector .
6	VSS Input	Green	Connect with a Posi-Tap to the gray w/ black tracer wire located at Pin 58 of the PCM Connector .
7	RPM Input	Yellow	Connect with a Posi-Tap to the white w/ pink tracer wire (2002-2003 trucks are a light green w/ white tracer wire) located at Pin 19 of the PCM Connector .
8	TPS Input	Tan	Connect with a Posi-Tap to the gray w/ white tracer wire located at Pin 89 of the PCM Connector .
9	Water Temp Input	Blue	Connect with a Posi-Tap at the red w/ white tracer wire at the "Engine Coolant Temperature Sensor" wiring harness located by the thermostat housing at the front of the engine. See the picture below for clarification.



10	Data Plug		Serial Connector for setup.
11	Data Plug		Serial Connector for setup.
12	Data Plug		Serial Connector for setup.

BD Engine Brake Inc.

Plant Address: 33541 MacLure Rd. Abbotsford, BC, Canada V2S 7W2

U.S. Shipping Address: 88-446 Harrison St, Sumas, WA 98295 U.S. Mailing Address: P.O. Box 231, Sumas, WA 98295

Phone: 604-853-6096 | Fax: 604-853-8749 | Internet: www.bd-power.com

Black Wiring Harness Connections

Using the wiring harness with the Black Plug from the TowLoc kit lay out the wires for hook up. Leave enough slack to allow to attach and remove the Black plug from the control module when the module is mounted. **NOTE:** DO NOT secure the control module just yet.

Pin	Function	Towloc Wire Color	Instructions
1	Switch Module	Green	Pass the telephone style wire through the firewall and under the steering column by piercing the rubber grommet below the master cylinder. Plug one end into the connector by the main black plug and plug the other end into the switch control box.
2	Switch Module	Yellow	
11	Switch Module	Black	
12	Switch Module	Red	
3	PressureLoc Output (if equipped)	Tan	Pass through the firewall and connect with a female blade connector to the TCC Terminal on the PressureLoc control module under the dash. Follow the directions below that are applicable to your vehicle.

IF A BD PRESSURELOC IS INSTALLED (see diagram on page 26):

4	TCC Output to Transmission	Blue	Connect a female blade connector to this wire and connect to the blue wire from the BD PressureLoc wiring harness.
9	TCC Input from PCM	Yellow	Connect a female blade connector to this wire and connect to the yellow wire from the BD PressureLoc wiring harness.

IMPORTANT: The **purple w/ yellow tracer** wire **DOES NOT** have to be cut if a PressureLoc has been, or is being installed. Utilize the harness that comes in the PressureLoc kit for connections.

IF THERE IS NO BD PRESSURELOC PRESENT (see diagram on page 27):

Cut the purple w/ yellow wire about 4-6" from the connector. This will allow for a good length to work with.

4	TCC Output to Transmission	Blue	Locate the violet w/ yellow tracer wire at Pin #54 (1999-2003 models) located at the PCM Connector. (Pin #28 on 1994-1997 models) . Connect a blue Posi-Lock connector to this wire and attach the other end to the wire that goes to the transmission.
9	TCC Input from PCM	Yellow	Connect a blue Posi-Lock connector to this wire and attach the other end to the wire that

BD Engine Brake Inc.

Plant Address: 33541 MacLure Rd. Abbotsford, BC, Canada V2S 7W2

U.S. Shipping Address: 88-446 Harrison St, Sumas, WA 98295 U.S. Mailing Address: P.O. Box 231, Sumas, WA 98295

Phone: 604-853-6096 | Fax: 604-853-8749 | Internet: www.bd-power.com

			goes to the PCM.
5	Shift In/Out	Brown	Connect with a Posi-Tap to the tan w/ white tracer wire located at Pin #29 of the PCM Connector .
Locate the black w/ yellow tracer wire at the Cruise Control Disable (Brake Applied) Switch located on the brake master cylinder. Cut the black w/ yellow tracer wire about 4-6" from the switch to allow a good length to work with.			
6	Cruise In/Out	White	Connect a blue Posi-Lock connector to one end of the cut black w/ yellow tracer wire and the other end to the white wire from the TowLoc.
7	Cruise In/Out	Pink	Connect a blue Posi-Lock connector to the other end of the cut black w/ yellow tracer wire and the other end to the pink wire from the TowLoc.
8	Shift In/Out	Violet	Connect a Posi-Tap to the red wire at Pin #1 (12V Switched Power) on the Gray TowLoc plug harness.
10	Exhaust Brake Control Valve	Gray	Connect to the wire from the control valve of the exhaust brake.

Attach the TowLoc control module to the firewall using a #8 sheet metal screw. **DO NOT OVER-TIGHTEN THIS SCREW OR THE CASE WILL BREAK.** Plug in the black and gray connector to the TowLoc control module and clean up the installation by tie wrapping the wiring in place, away from hot or moving components.

CAUTION: When plugging and unplugging the black & gray connectors, pull back on the connectors themselves **NOT** the wires connected them, otherwise the wires may break.

Toggle Switch Installation

NOTE: If an exhaust brake is previously installed, you can use the existing switch location.

- 1) Locate a convenient spot for the toggle switch on the dash or kick panel. Drill a pilot hole with a 1/8" drill bit, and then finish drilling the hole with a 1/2" drill bit.
- 2) Mount the switch in the hole, making sure that the notch in the neck of the switch is facing down, then secure with the lock ring. This will align the switch so that when it is in the "**UP**" position, the light on the end of the switch is red, and when it is in the "**DOWN**" position, it is green.
- 3) Ensure the telephone-style cable is plugged into the switch module and that the green connector holding the switch wires is attached securely.
- 4) Secure the switch module and any loose wires up under the dash and replace any panels or dash components that were previously removed.
- 5) Re-connect and battery connections.

The installation is for FORD VEHICLES is now complete. Please proceed directly to page 28 and continue with the 'PROGRAMMING THE TOWLOC' section.

Wiring Schematic (With PressureLoc Installed)

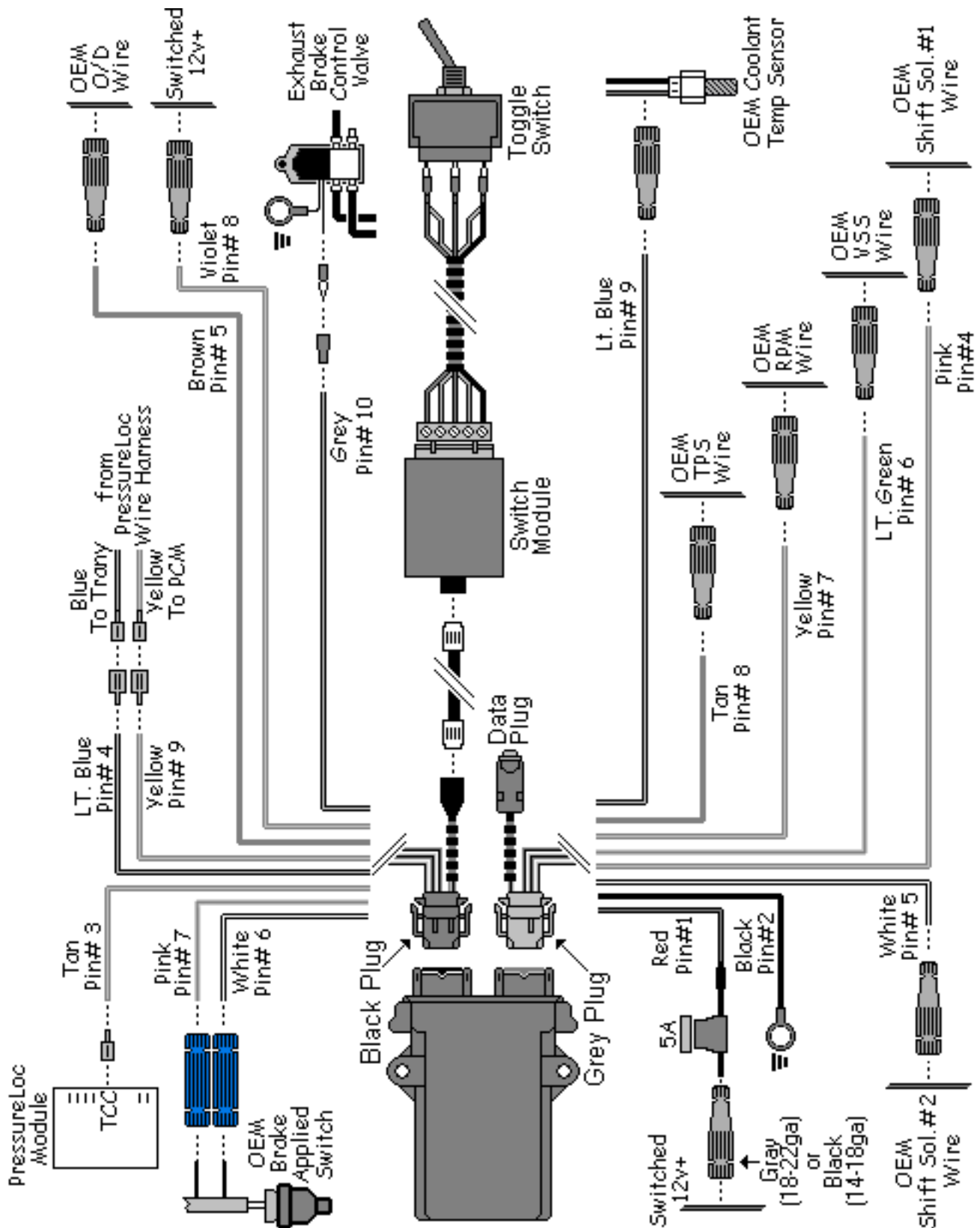

BD Engine Brake Inc.

Plant Address: 33541 MacLure Rd. Abbotsford, BC, Canada V2S 7W2

U.S. Shipping Address: 88-446 Harrison St, Sumas, WA 98295 U.S. Mailing Address: P.O. Box 231, Sumas, WA 98295

Phone: 604-853-6096 | Fax: 604-853-8749 | Internet: www.bd-power.com

Wiring Schematic (Without PressureLoc Installed)

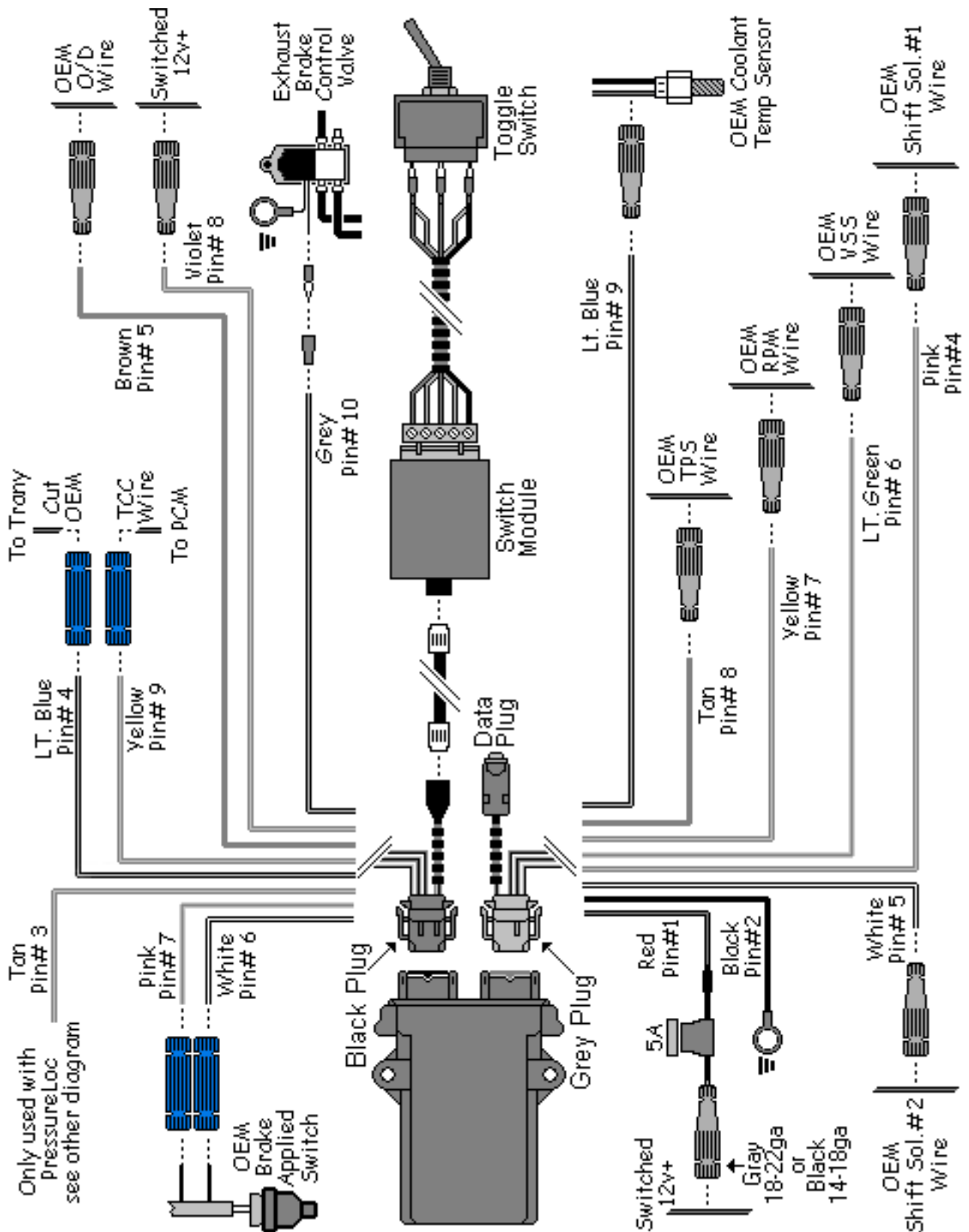

BD Engine Brake Inc.

Plant Address: 33541 MacLure Rd. Abbotsford, BC, Canada V2S 7W2

U.S. Shipping Address: 88-446 Harrison St, Sumas, WA 98295 U.S. Mailing Address: P.O. Box 231, Sumas, WA 98295

Phone: 604-853-6096 | Fax: 604-853-8749 | Internet: www.bd-power.com

Programming the TowLoc

The programming functions of the TowLoc module can be accessed with a laptop PC or Palm Pilot using a serial cable (If your computer does not have a serial cable connection but has USB, a USB -> Serial adapter cable can be purchased separately – P/N 1607080). To communicate with the TowLoc, use the “Hyper Terminal” program, which comes standard with Windows 98/2000/XP.

Configuring a PC Laptop with Hyper Terminal

To Load HyperTerminal:

- Click Start > Run
- In the box which appears type in: **HYPERTRM**
- Click OK.

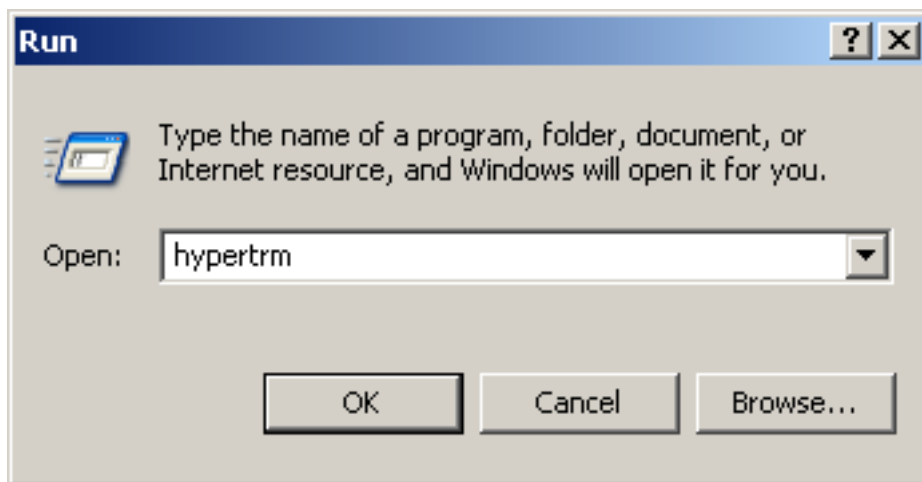

If you see the error message 'Cannot find HYPERTRM' then HyperTerminal is not installed. You will need this program to configure the TowLoc. To install HyperTerminal:

- Click Start > Settings > Control Panel > Add / Remove Programs.
- In Add / Remove Programs select Properties and then click the Windows Setup tab.
- Double-click Communications
- Check the box for HyperTerminal
- Click OK, and then OK again to install.
- **Note:** You may be asked for your Windows installation disk for this procedure.

Or,

Click Start > Programs > Accessories > Communications > HyperTerminal

BD Engine Brake Inc.

Plant Address: 33541 MacLure Rd. Abbotsford, BC, Canada V2S 7W2

U.S. Shipping Address: 88-446 Harrison St, Sumas, WA 98295 U.S. Mailing Address: P.O. Box 231, Sumas, WA 98295

Phone: 604-853-6096 | Fax: 604-853-8749 | Internet: www.bd-power.com

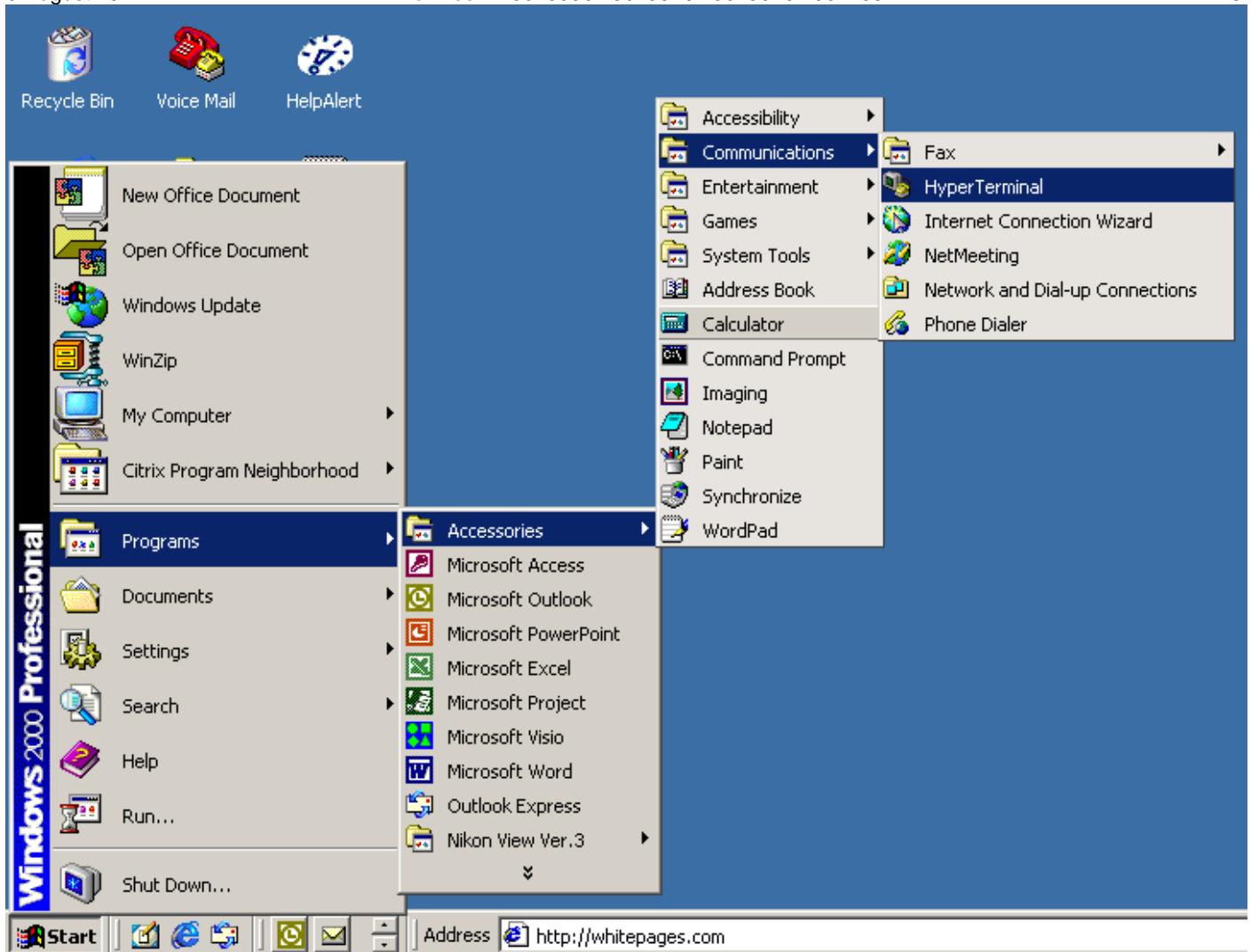

When HyperTerminal starts, you will be presented with a '**Connection Description**' dialogue box.

Type in a name for your connection like '**TowLoc**' then pick an icon of your choice and click '**OK**'



You will then be asked how you wish the connection to be made.

Ensure that the serial cable is plugged into the computer and that you choose either COM port (usually COM2).



You will then be asked how to set the Port Settings.

Ensure the settings are as follows:

- ✓ Bits per second '19200'
- ✓ Data bits '8'
- ✓ Parity 'None'
- ✓ Stop bits '1'
- ✓ Flow Control 'None'

Then click 'OK'.

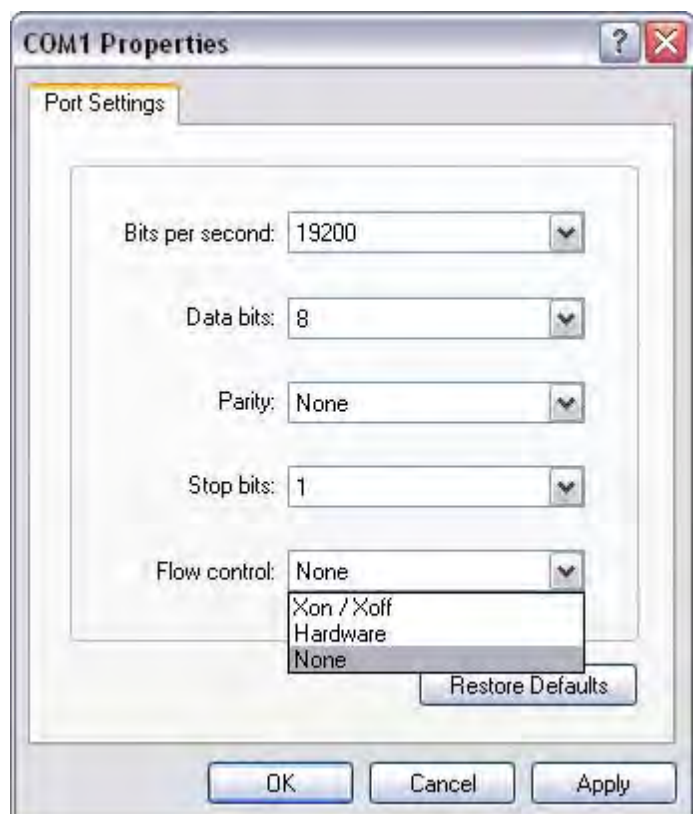

Once you are at the main screen of HyperTerminal, click on the "File" pull-down menu on the top left-hand side of the window and select "Properties". This will bring up the Settings screen. The settings should be as follows:

Function, arrow, and ctrl keys act as: "Terminal keys"

Emulation: "Auto detect"

Telnet terminal ID: "ANSI"

Backscroll buffer lines: "500"

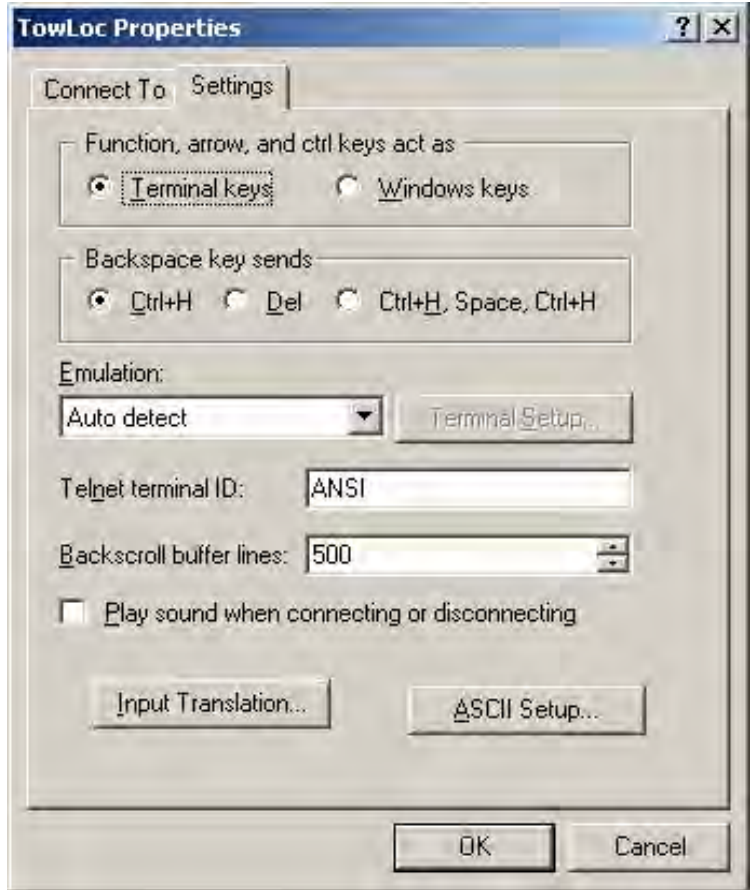

On the top of the properties window there are two tab options: "Connect To" and "Settings". Click on the "Connect To" tab. Click "Configure" under the COM port you selected to use with the TowLoc. This should bring up a screen similar to the one displayed on the right. The settings for the terminal should be as follows:

- BPS** 19200
- Data Bits** 8
- Parity** None
- Stop Bits** 1
- Flow Control** None

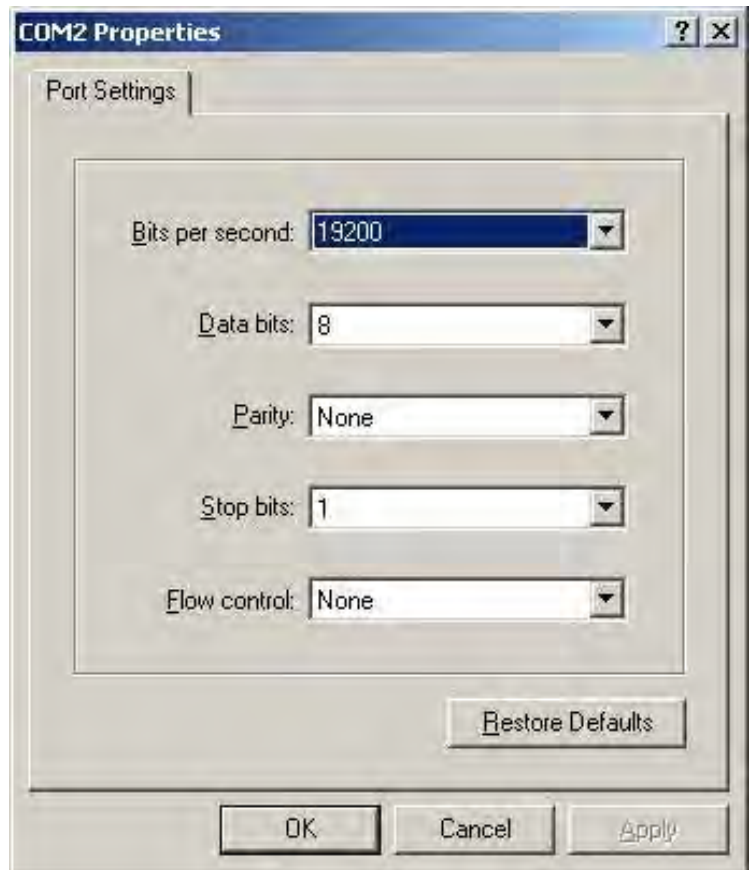

Configuring a Palm Pilot

The programming functions of the TowLoc module can be accessed with a laptop PC or Palm Pilot using a serial cable (If your computer does not have a serial cable connection but has USB, a USB-to-serial adapter cable can be purchased separately – **P/N 1607080**).

If you are using a Palm Pilot OS hand held device, you will have to download a third-party program to allow the Palm to communicate with the TowLoc module. We have chosen 'Mark Space' from www.markspace.com because of its ease of use.



Open the options menu and select the "Communications" option. This will bring up the configuration window.



The settings for the terminal are as follows:

Method	Serial
Port	Serial
Baud	19200
Data Bits	8
Parity	N
Stop Bits	1
Handshake	None

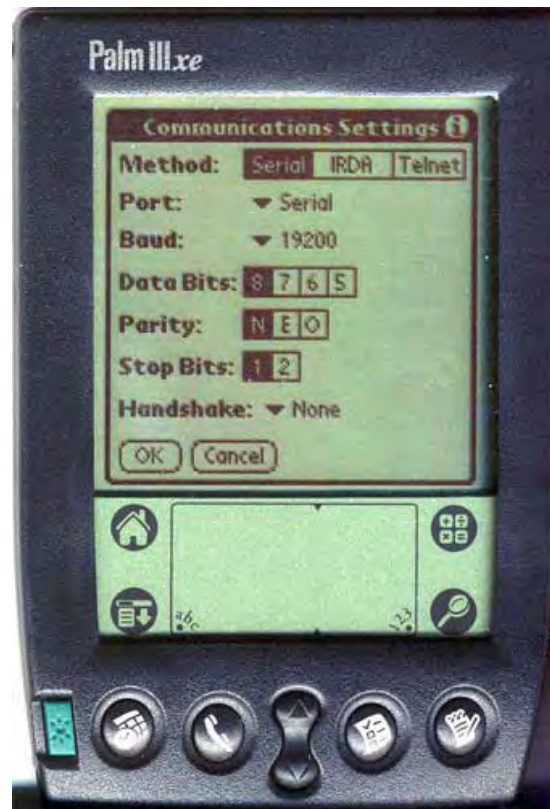

Programming Procedure

Upon successful connection to the TowLoc (provided the vehicle is on and the TowLoc is powered properly), the user will be greeted with a simple display structure:

Spd	RPM	TPS	Wtr	BW	NW	Md	Gr
0	290	0	250	00	00	ST	4

This display represents:

- Spd** Vehicle Speed
- RPM** Engine RPM
- TPS** Throttle Position (%)
- Wtr** Relative Coolant Temperature
- BW** Brake Warm Up (Diagnostic)
- NW** Needs Warm Up (Diagnostic)
- Md** TowLoc Mode:
St: Stock / TL: TorqLoc / AL: AutoLoc
- Gr** Current Transmission Gear

NOTE: If you do not see a line of numbers across the top of the Palm Pilot display, make sure that the 'ON' (Online) icon is black indicating the program is ON LINE with the TowLoc.

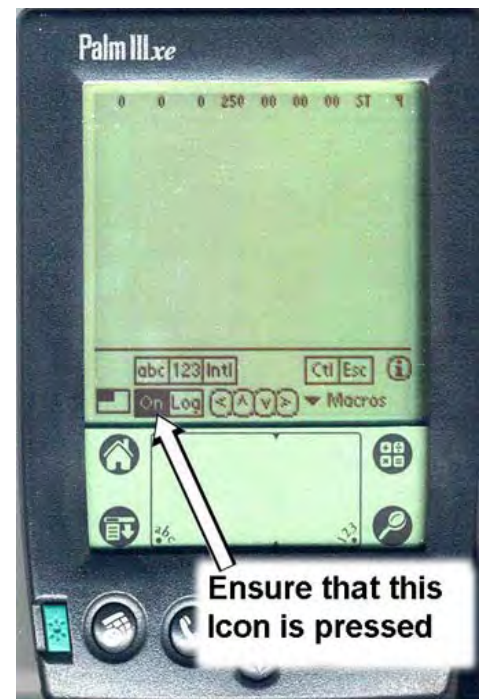

TPS Calibration

The first thing that must be done after installing the TowLoc is to calibrate the Throttle Position Sensor (TPS) with the TowLoc. This calibration must be done with the ignition **Key in the on** position and the **engine NOT running (KOEO)**.

Pressing Ctrl-T on the PC keyboard accesses the TPS calibration menu.

To access the TPS menu on the Palm Pilot, press the "CTL" key and draw a "T" in the workspace box.

The diagram on the next page should be displayed.

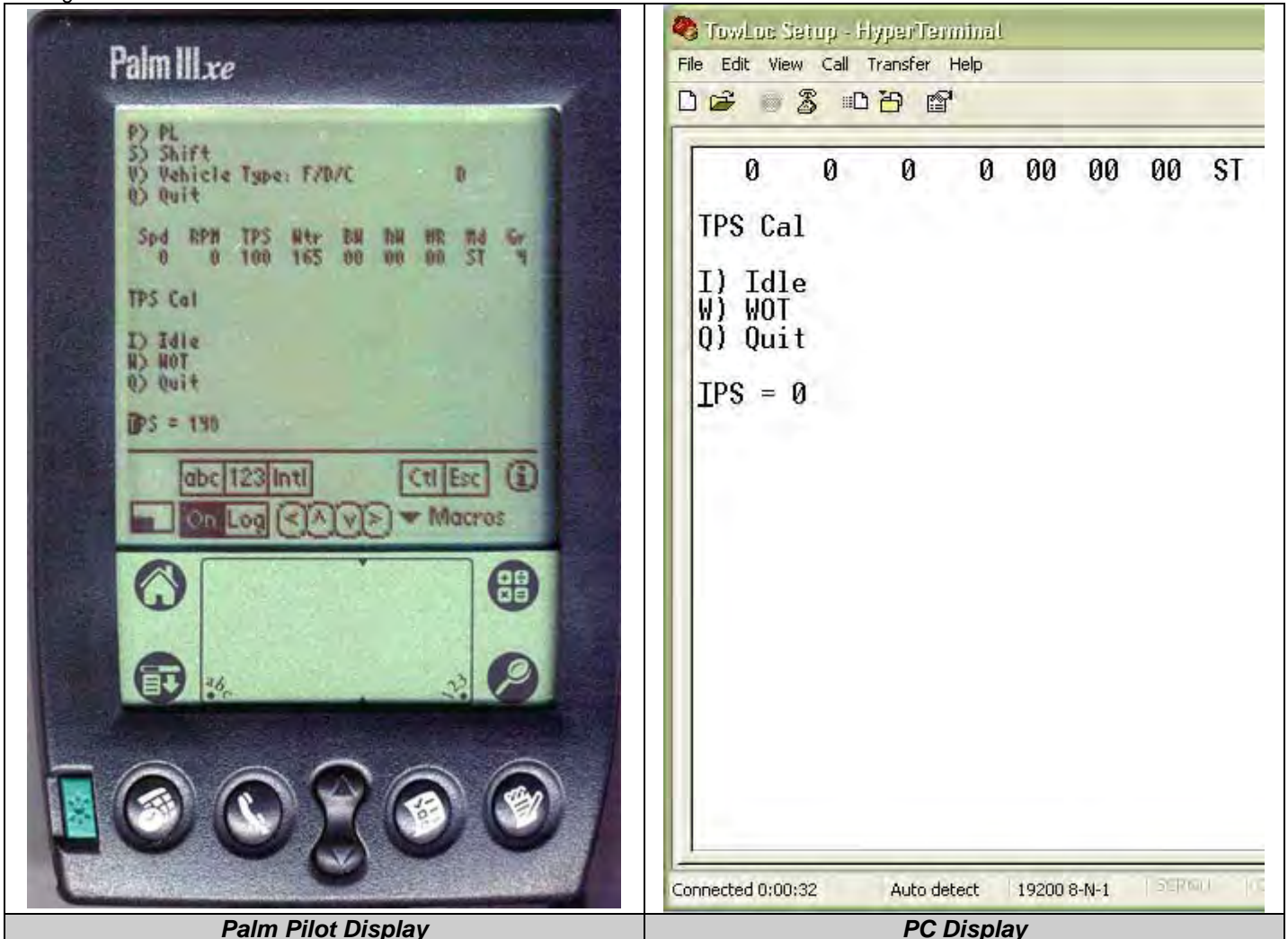
*Palm Pilot Display**PC Display*

DO NOT touch the throttle pedal with this menu displayed. Press the “I” key on the keyboard - this will record the value at idle.

Press and hold the throttle pedal to the floor (WOT) and once the TPS value on the display stabilizes, press the “W” key on the keyboard - this will record the WOT (wide-open throttle) value.

Release the throttle pedal and then press the “Q” key on the keyboard to quit.

That is all that is needed to set the TPS calibration. Press on the throttle and watch the terminal display to confirm the TPS setting changes from 0 to 100 as the pedal moves up and down.

TowLoc Calibration

The next calibration that must be done is to change the parameters of the TowLoc itself and customize the product. The main programming console can be accessed by pressing **Ctrl-C**.

BD Engine Brake Inc.

Plant Address: 33541 MacLure Rd. Abbotsford, BC, Canada V2S 7W2

U.S. Shipping Address: 88-446 Harrison St, Sumas, WA 98295 U.S. Mailing Address: P.O. Box 231, Sumas, WA 98295

Phone: 604-853-6096 | Fax: 604-853-8749 | Internet: www.bd-power.com

Upon entering the console, you will see:

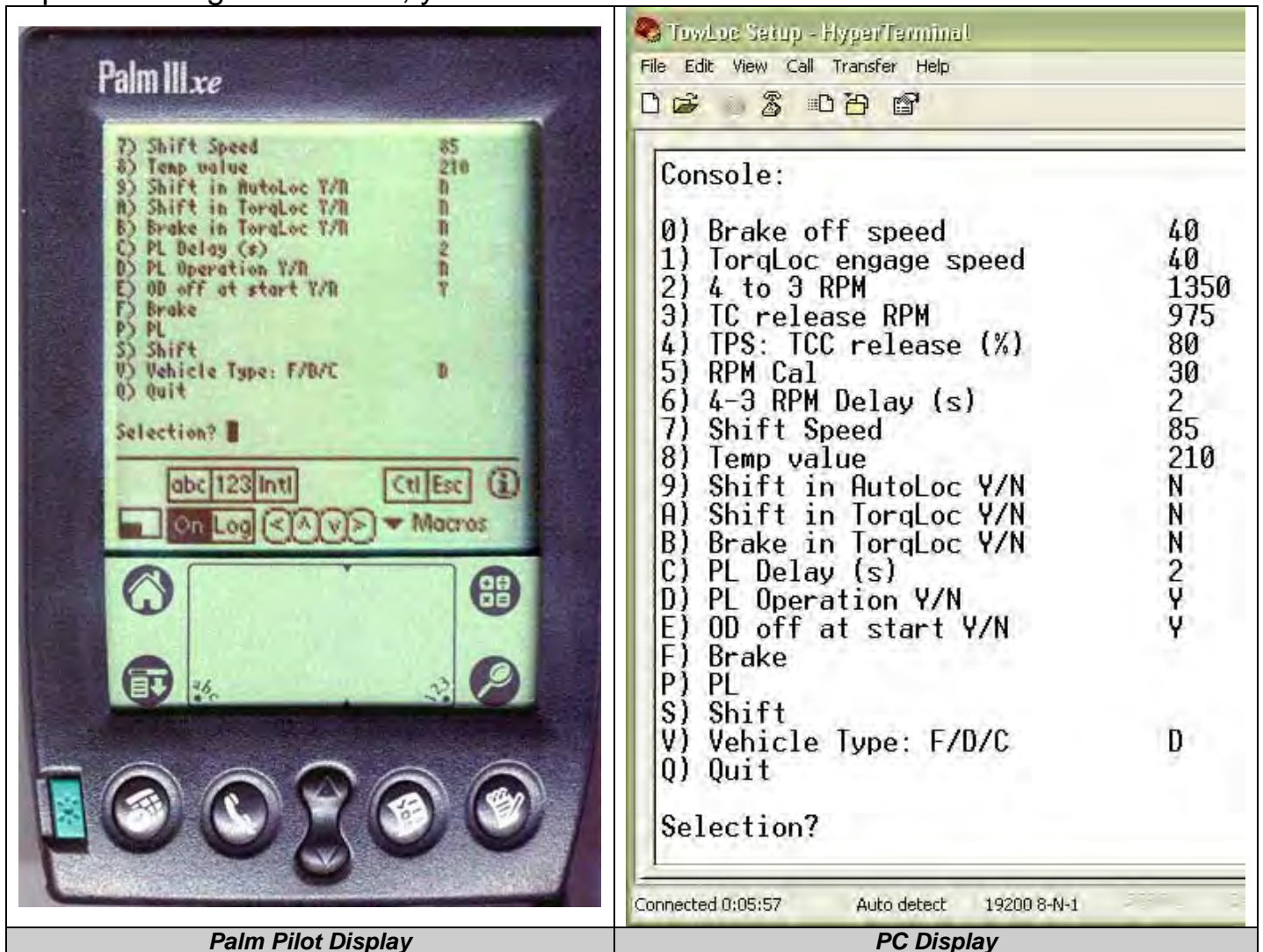

NOTE: If you do not see this part of the display on a Palm Pilot, try touching the square at the bottom left to move the display in order to view. See diagram on the next page.

0) Brake off speed	40	8) Temp value	210
1) TorqLoc engage speed	40	9) Shift in AutoLoc Y/N	N
2) 4 to 3 RPM	1350	A) Shift in TorqLoc Y/N	N
3) TC release RPM	975	B) Brake in TorqLoc Y/N	N
4) TPS: TCC release (%)	80	C) PL Delay (s)	2
5) RPM Cal	30	D) PL Operation Y/N	N
6) 4-3 RPM Delay (s)	2	E) OD off at start Y/N	Y
7) Shift Speed	85	F) Brake	
8) Temp value	210	P) PL	
9) Shift in AutoLoc Y/N	N	S) Shift	
A) Shift in TorqLoc Y/N	N	V) Vehicle Type: F/D/C	D
B) Brake in TorqLoc Y/N	N	Q) Quit	
C) PL Delay (s)	2		

Selection? █

Move the display around by touching this box with stylus

Console:

0) Brake Off speed	40
1) TorqLoc engage speed	40
2) 4 to 3 RPM	1350
3) TC release RPM	975
4) TPS: TCC release (%)	80
5) RPM Cal	30
6) 4-3 RPM Delay (s)	2
7) Shift Speed	85
8) Temp value	210
9) Shift in AutoLoc Y/N	N
A) Shift in TorqLoc Y/N	N
B) Brake in TorqLoc Y/N	N
C) PL Delay (s)	2
D) PL Operation Y/N	N
E) OD off at start Y/N	Y
F) Brake	
P) PL	
S) Shift	
V) Vehicle Type: F/D/C	D
Q) Quit	
Selection?	

BD Engine Brake Inc.

Plant Address: 33541 MacLure Rd. Abbotsford, BC, Canada V2S 7W2

U.S. Shipping Address: 88-446 Harrison St, Sumas, WA 98295 U.S. Mailing Address: P.O. Box 231, Sumas, WA 98295

Phone: 604-853-6096 | Fax: 604-853-8749 | Internet: www.bd-power.com

Menu Item Descriptions

Menu Option	Def.	Description
0) Brake Off Speed	40	This setting determines at what speed the engine brake will turn off. In all TowLoc modes, the engine brake will deactivate below this speed.
1) TorqLoc Engage Speed	40	In TorqLoc mode, the TC will not lock up until the vehicle speed is above set value.
2) 4 to 3 RPM	1350	This determines at what engine rpm the 4 th to 3 rd automatic downshift will occur, only when the shift feature #9 and/or #A is turned on.
3) TC Release RPM	975	This setting determines when the TCC will be unlocked regardless of TowLoc mode (other than stock) or gear. If the engine speed is less than setting, the TCC will not lock up. This is to protect the TCC and prevent TC shudder.
4) TPS: TCC Release (%)	80	This setting determines at what percentage of Throttle Position that the TCC will be released. This only occurs in TowLoc mode. NOTE: If the throttle position is over the set amount, the TCC will unlock into a fluid coupling and the switch light will flash.
5) RPM Cal	30	This is a calibration factor for the Engine RPM sensor. Typically on Dodge the setting is 30 and on Ford the setting is 15 . For 2004 and newer Dodges you will need to set this to 9 . This is because the Dodge has 4 pulses per crank revolution and the Ford has 2 pulses per revolution.
6) 4-3 RPM Delay (s)	2	This delay is in place to allow the engine RPM to come back up after a shift. If this delay was not here, the TowLoc would immediately release the TCC after a shift as a result of the rpm drop due to fluid coupling. Typically this should be delay of 1 or 2 seconds.
7) Shift Speed	85	The shift speed is for safety. The automatic shift will not allow a shift until the vehicle is going slower than the set speed. CAUTION: A potential problem exists if the

BD Engine Brake Inc.

Plant Address: 33541 MacLure Rd. Abbotsford, BC, Canada V2S 7W2

U.S. Shipping Address: 88-446 Harrison St, Sumas, WA 98295 U.S. Mailing Address: P.O. Box 231, Sumas, WA 98295

Phone: 604-853-6096 | Fax: 604-853-8749 | Internet: www.bd-power.com

		shift speed is set lower than the shift rpm, the vehicle will never downshift automatically. The suggested setting is 85(km) or 50(mph).
8) Temp Value	210	This setting is for the engine warm up feature of the unit. This value setting is NOT for temperature, it is a calibration setting. Dodge will be initially set at 210, and Ford will be set at 640. The lower the set value, the hotter the engine will be before the exhaust brake is shut off. NOTE: The warm up feature is only available in AutoLoc mode; if the customer does not want the engine warm up feature, switch to Stock, TorqLoc, or UnLoc mode.
9) Shift In AutoLoc (Y/N)	N	This will allow the transmission to downshift while in AutoLoc mode. This feature is turned off for safety reasons. The customer must request this feature turned on. On 2005 Dodge vehicles this option should be disabled. **SAFETY: This reasoning is based on what could happen when an unexpected downshift occurs. In icy or wet conditions if a downshift is unexpected, the vehicle could end up sideways. **
A) Shift In TorqLoc (Y/N)	N	This will allow the transmission to downshift while in TorqLoc mode. This feature is turned off for safety reasons. The customer must request this feature turned on. On 2005 Dodge vehicles this option should be disabled.
B) Brake In TorqLoc (Y/N)	N	This will allow for engine brake to be on in TorqLoc mode. NOTE: Some customers like the added braking and some don't.
C) PL Delay (S)	2	This is the amount of delay time between TCC lock up and PressureLoc engagement. This feature prevents both the TCC and PressureLoc from engaging at the same time providing a staged lock up and pressure increase. The PressureLoc operates based on the TCC signal from the ECM. When a TCC lockup is initiated by the ECM then the PressureLoc will engage after the time set.

D) PL Operation (Y/N)	N	This allows for PressureLoc operation depending on customer wishes or if a PressureLoc is installed.
E) OD off at start (Y/N)	Y	This feature cancels the OD when the vehicle is started and the VSS exceeds approximately 5 MPH. It's like hitting the OD button with your finger before you get very far after startup. On 2005 Dodge Vehicles this feature controls tow/haul mode.
F) Brake		This will perform a test of the exhaust brake to help determine if it is working. The test will be performed for 3 seconds.
P) PL		This will perform a test of the PressureLoc (provided one is installed) for 3 seconds. Using a gauge you can observe the pressure increase without the need for a road test.
S) Shift		This will perform a test of the transmission shift function. This will be just like hitting the OD button.
V) Vehicle Type (F/D/C)	D	This indicates what type of vehicle the TowLoc is connected to. This setting is necessary as Ford and Dodge indicate gearing differently. F = Ford, D = Dodge, and C = Chev. (The TowLoc is not yet available for Chev)
Q) Quit		This will exit out of the programming console.

Speed Calibration

The last calibration that needs to be done is Speed Calibration.

**** CAUTION: THIS PROCEDURE MUST BE COMPLETED AT DRIVING SPEEDS AND THEREFORE SHOULD NOT BE ATTEMPTED BY THE DRIVER ALONE AS SAFETY BECOMES A FACTOR. AN ASSISTANT SHOULD DO THE ACTUAL CALIBRATION WHILE THE DRIVER CONCENTRATES ON MAINTAINING THE SET SPEED. ****

- 1) To adjust the speed calibration, have a computer or Palm Pilot connected to the TowLoc.

BD Engine Brake Inc.

Plant Address: 33541 MacLure Rd. Abbotsford, BC, Canada V2S 7W2

U.S. Shipping Address: 88-446 Harrison St, Sumas, WA 98295 U.S. Mailing Address: P.O. Box 231, Sumas, WA 98295

Phone: 604-853-6096 | Fax: 604-853-8749 | Internet: www.bd-power.com

When you are reading:

SPD	RPM	TPS	Wtr	BW	NW	Md	Gr
72	2970	0	642	00	00	ST	4

2) Enter the speed calibration menu by pressing **CTRL-S**.

You will be presented with the following simple interface:

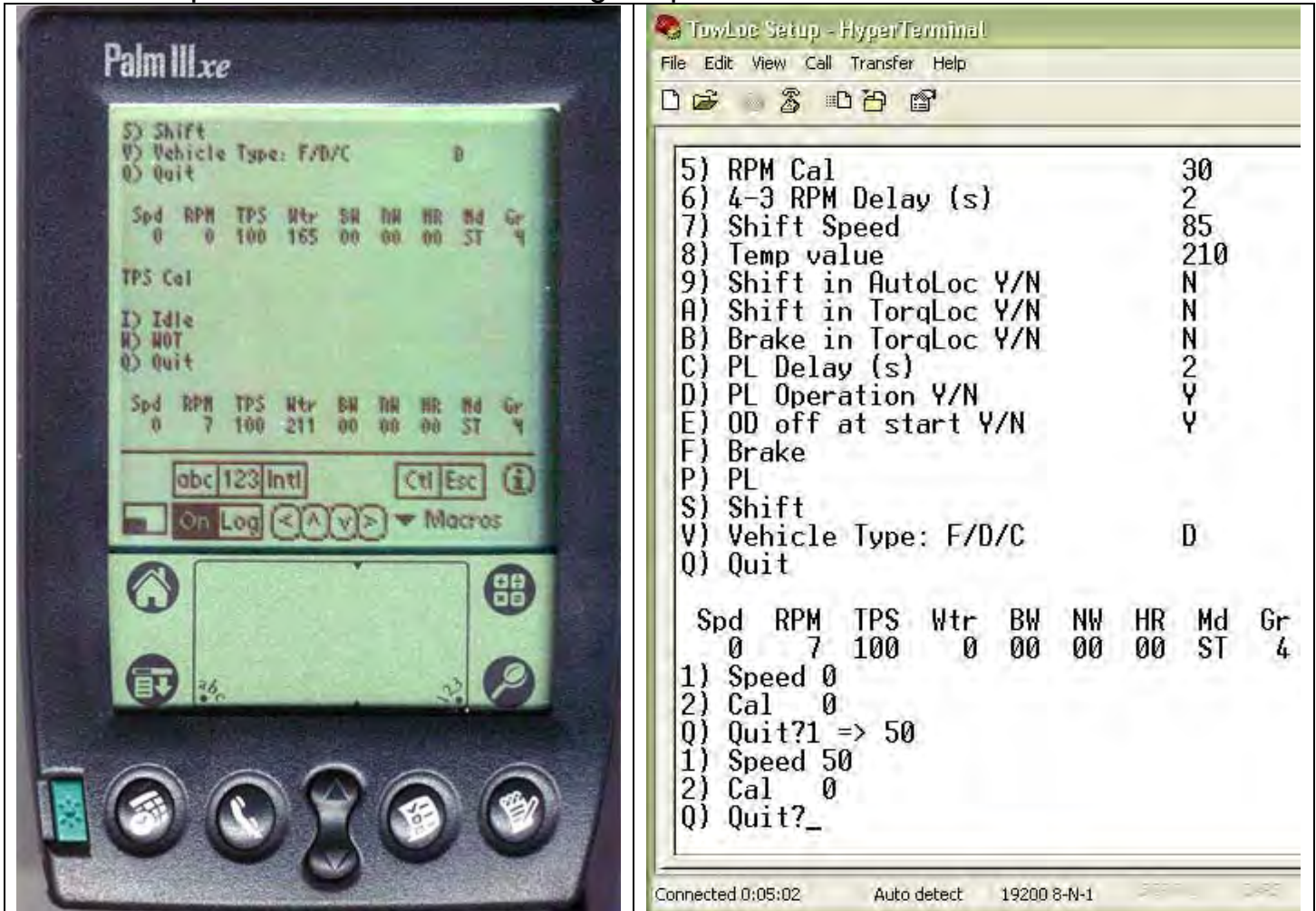

- 1 Speed 0
- 2 Cal 0
- Q Quit?

NOTE: This step can be done while the vehicle is at a stop.

3) You will need to enter a speed at which to do the calibration.

Note: It does not matter which unit you calibrate in, only that you drive to the speed you've set for calibration. Whichever unit of measure you used, all other TowLoc functions will be based on that unit of measure. For example, if you calibrate the

BD Engine Brake Inc.

Plant Address: 33541 MacLure Rd. Abbotsford, BC, Canada V2S 7W2

U.S. Shipping Address: 88-446 Harrison St, Sumas, WA 98295 U.S. Mailing Address: P.O. Box 231, Sumas, WA 98295

Phone: 604-853-6096 | Fax: 604-853-8749 | Internet: www.bd-power.com

option in km/H (kilometers per hour), the TowLoc works in km/H; if you calibrate in MPH (miles per hour), the TowLoc works in MPH.

- a) Press the **1** on the keyboard or Palm Pad.

The display will show:

```

1 Speed 0
2 Cal 0
Q Quit? 1=>

```

- b) Type or draw your calibration number (we have used 50), and press **Enter** (keyboard) or draw **Enter** (Palm).



NOTE: To draw the 'Enter' command on the Palm, place the stylus near the top right side of the pad and draw a line downwards, on an angle from right to left.

The Palm interprets this as an "Enter" command.

You should end up with this display:

```

1) Speed 0
2) Cal 0
Q) Quit?1=>50
1) Speed 50
2) Cal 0
Q) Quit?

```

- 4) Test drive the vehicle while keeping the speed up until you have reached your set speed, and then maintain it by keeping a steady speed.
- 5) Press the **2** on the keyboard or Palm pad to initiate the speed setting and confirm the calibration.

This is what you will see:

```

1) Speed 0

```

BD Engine Brake Inc.

Plant Address: 33541 MacLure Rd. Abbotsford, BC, Canada V2S 7W2

U.S. Shipping Address: 88-446 Harrison St, Sumas, WA 98295 U.S. Mailing Address: P.O. Box 231, Sumas, WA 98295

Phone: 604-853-6096 | Fax: 604-853-8749 | Internet: www.bd-power.com

2) Cal 0
Q) Quit?1=>50
1) Speed 50
2) Cal 0
Q) Quit?2=>
1) Speed 50
2) Cal 735
Q) Quit?

6) Next, enter “Q” to quit. The calibration value, in this case **735**, will be stored in the EEPROM memory of the TowLoc.

You are now ready to enjoy the Transmission and Torque Converter Control Strategy System by BD.

Road test the vehicle and then try some different settings to customize this system to your own driving habits.

Questions?

If you any questions about this product or have any interest in other performance products please visit our website at www.bd-power.com or contact the BD Customer or Technical Support at 1-800-887-5030. Support can also be attained by accessing the BD Power Technical Forums at <http://bd-power.com/forum/> .

Troubleshooting

Complaint	Query	Solution
I can't connect to the TowLoc!	Does the light on the switch flash when you turn the ignition on?	If Yes – The TowLoc's power and ground connections are good.
		If No – Check the fuses, power and ground connections first. If they look okay, then trace all wires to the switch module, and test the resistance (ohms) for continuity, and repair as needed.
Hyper Terminal says it's "Connected" but I get nothing on the screen!		<p>Check your cable for cuts and make sure the cable doesn't say <i>NULL</i> or <i>NULL MODEM</i> as they are incompatible. If the cable looks OK, then try the following steps:</p> <ul style="list-style-type: none"> • There may be a problem with the settings on your computer. Re-check them all and try all available COM ports. • If you are using a USB to serial convertor, make sure that the driver is installed, and if possible, test another device on it. • Disable any unnecessary serial port devices as there have been some cases where on-board devices (such as modems) have conflicted with the serial convertors.
I get all kinds of garbage on the screen when I'm connected to Hyper Terminal.		The cable is bad, or the terminal mode is wrong with Hyper Terminal. If the Auto-Detect option isn't working for you, then try the different terminal modes until you find one that works.

The biggest communication problem is with USB to Serial drivers. Be sure to install the supplied software before you plug in the USB-Serial Converter. To verify that you have the driver installed you will need to look in the device manger. To do this,

'Click' the Start menu
then Control Panel
then System
then Hardware
then Device Manager

Once in Device Manager, scroll to the PORTS (COM & LPT), expand the tree. You should see a port labeled something along the lines "USB to SERIAL (COM2)". You want to make sure this is a COM Port between 1 and 4. If it is not, consult your USB to Serial Driver software to see how to change this. Remember this port as you will use it to communicate with the towloc with it.

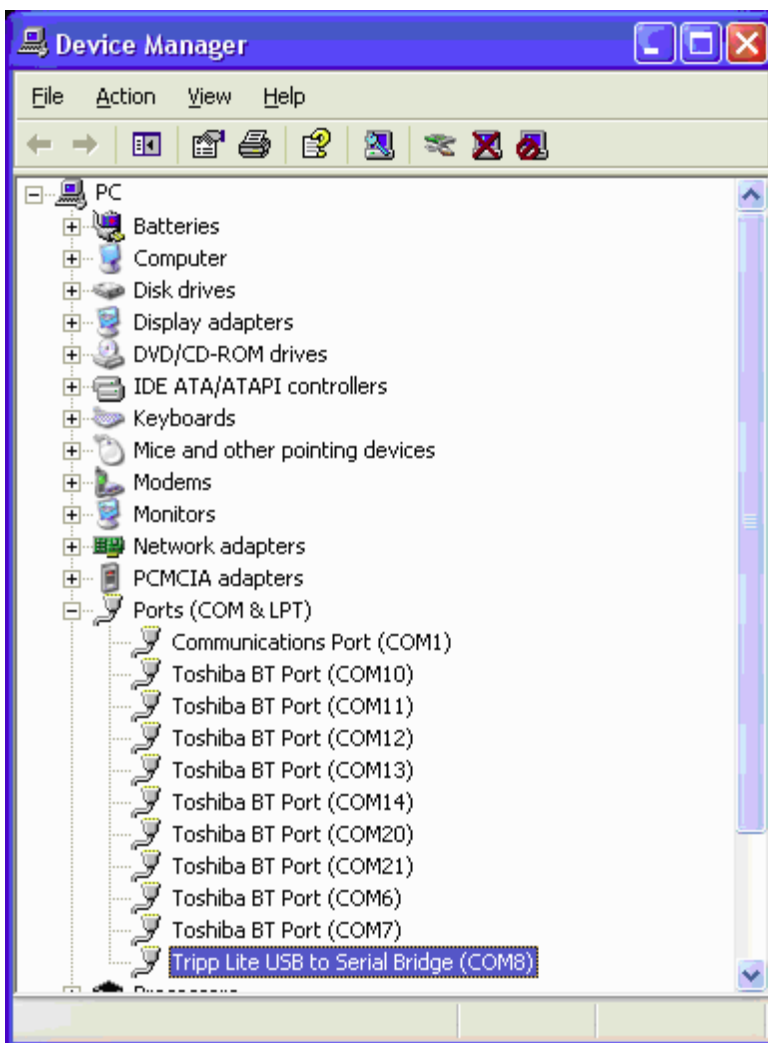

COM PORT Functional TEST

BD Engine Brake Inc.

Plant Address: 33541 MacLure Rd. Abbotsford, BC, Canada V2S 7W2

U.S. Shipping Address: 88-446 Harrison St, Sumas, WA 98295 U.S. Mailing Address: P.O. Box 231, Sumas, WA 98295

Phone: 604-853-6096 | Fax: 604-853-8749 | Internet: www.bd-power.com

Here is a little trick you can do to verify the driver is correctly, COM Port is working and cable is correct. It is called a serial loop back. What we will do is send out a serial signal and then receive it immediately back to the computer. This will prove out that the computer can receive and transmit data.

With the cable attached to the computer COM port, locate the DB9 end connector that will plug into the towloc.

Now locate pins 2 and 3, you will need to connect them together using an alligator clip. BE SURE NOT TO SHORT THESE CONNECTIONS WITH ANY OTHER PINS OR THE BODY OF THE CONNECTOR.

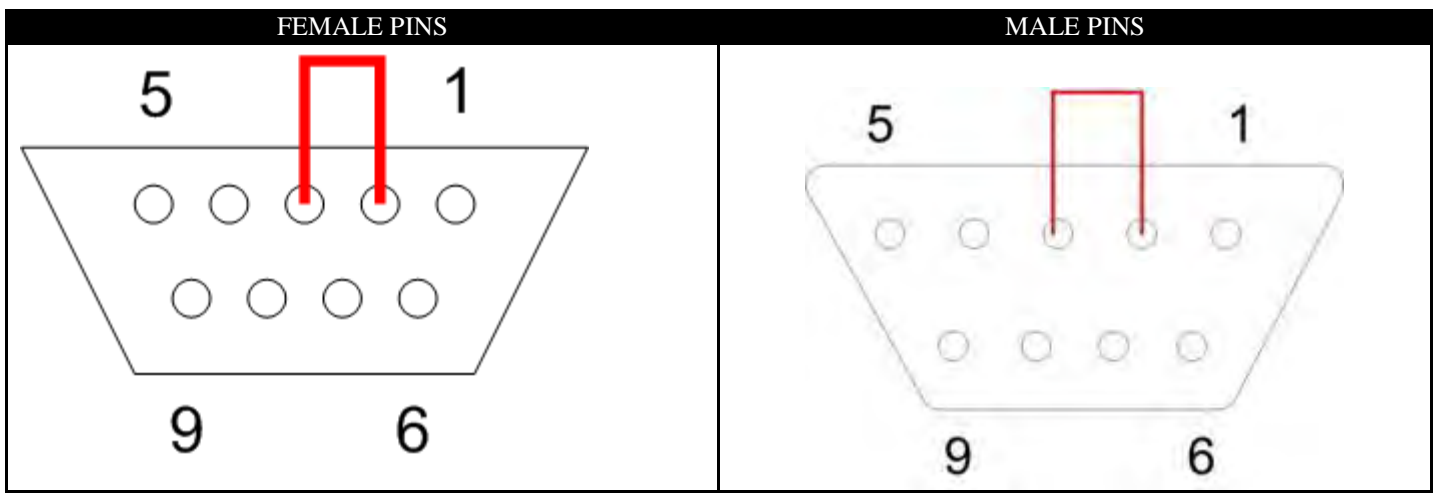

With this two pins connected that data that you send from the computer will go right back to it.

Now start up hyper terminal, and create a new connection called Loopback.

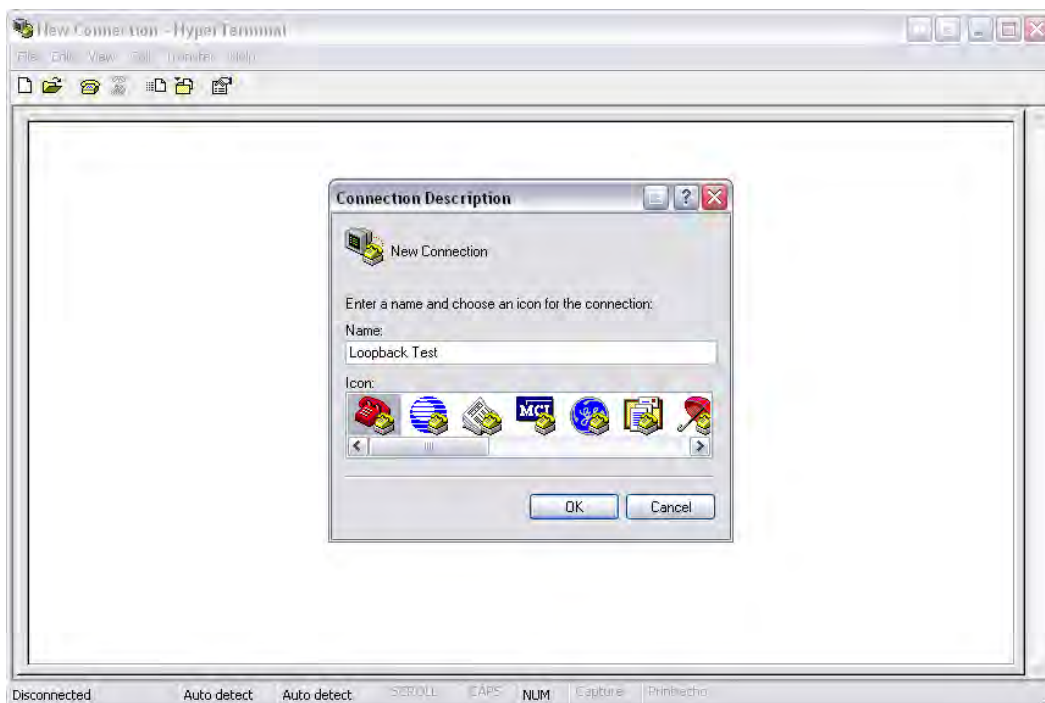

Now choose the correct port number (Between COM1 and COM4)

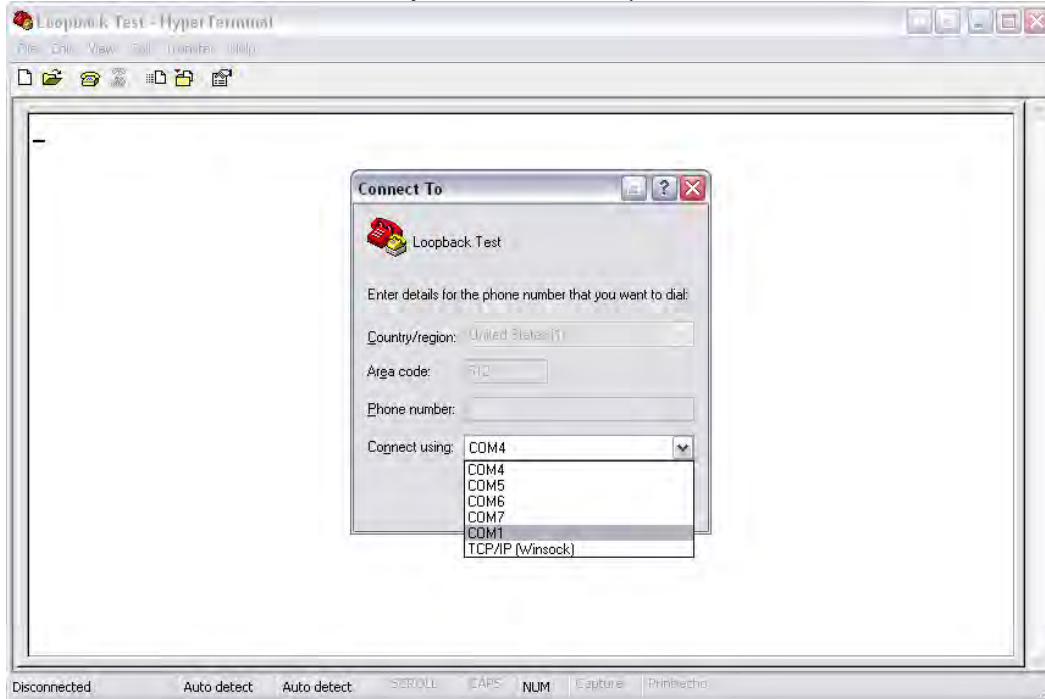

Choose the correct settings,
Baud Rate = 19200
Data bits = 8
Parity = None
Stop Bits = 1
Flow Control = None

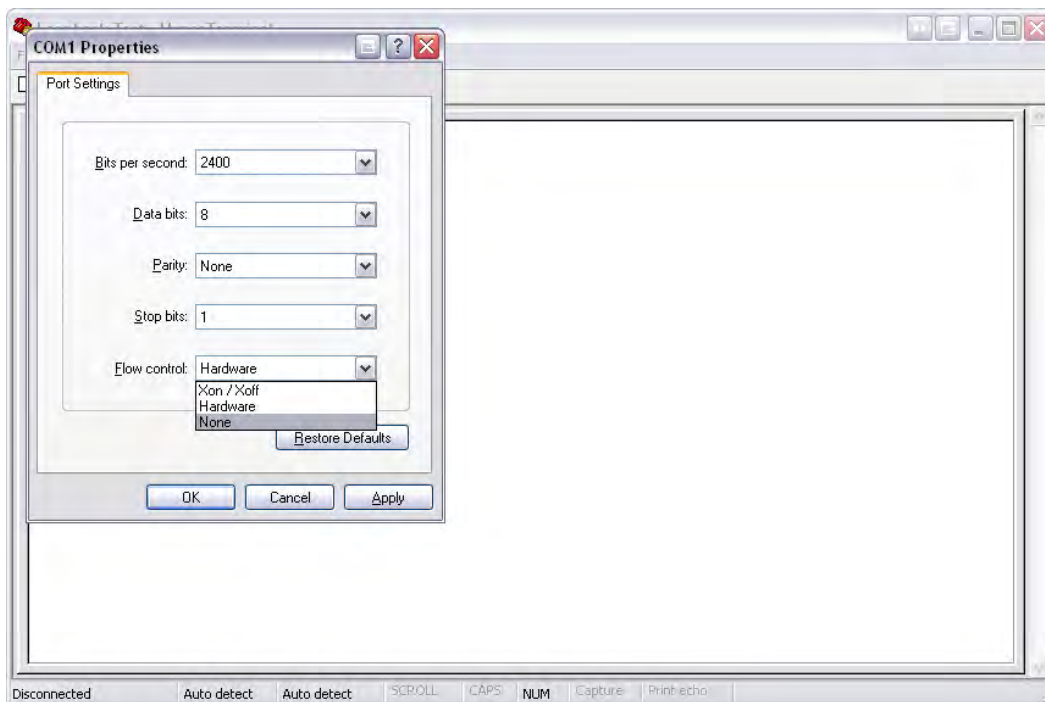

Starting type in the command window, if you see the same text appear as what you type, you have verified the connection.

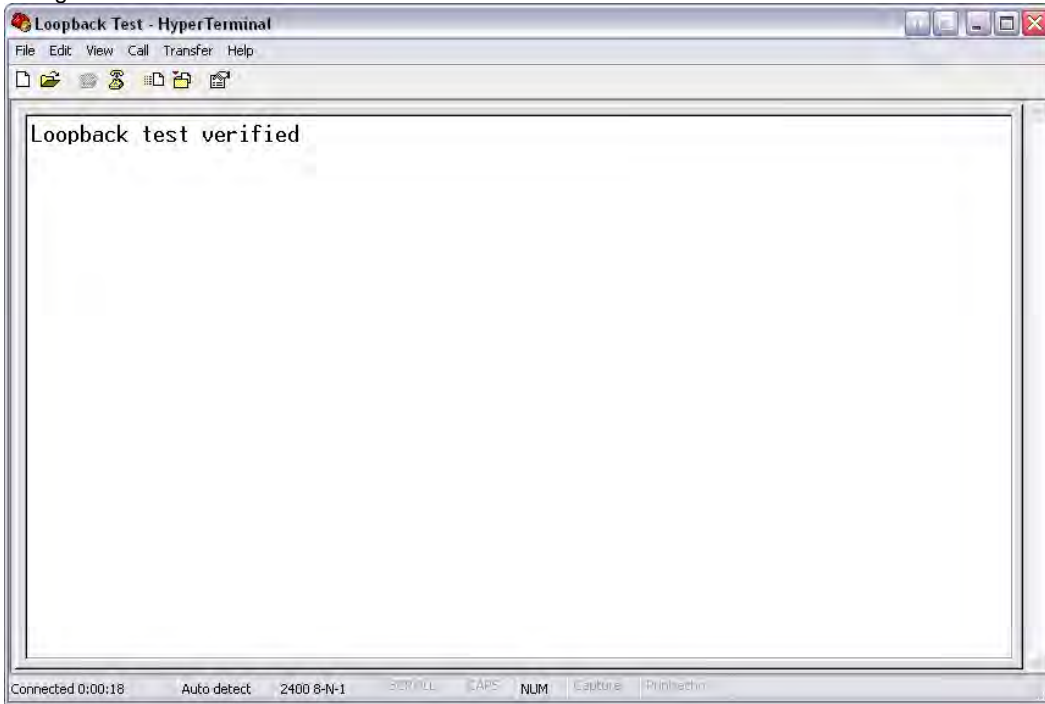

BD Engine Brake Inc.

Plant Address: 33541 MacLure Rd. Abbotsford, BC, Canada V2S 7W2

U.S. Shipping Address: 88-446 Harrison St, Sumas, WA 98295 U.S. Mailing Address: P.O. Box 231, Sumas, WA 98295

Phone: 604-853-6096 | Fax: 604-853-8749 | Internet: www.bd-power.com