



BD SPEED ELIMINATOR

Ford 6.0L Powerstroke Installation Instructions
For use on 2003-2007 Vehicles

PLEASE READ ALL INSTRUCTIONS BEFORE INSTALLATION.

This product will not work on the E-Series and F-450, F-550 vehicles.

Cautionary Note:

Please read the disclaimer before proceeding to install this unit. If you do not have the appropriate speed rated tires, then do not install this unit.

BD Engine Brake Inc.

Plant Address: 33541 MacLure Rd. Abbotsford, BC, Canada V2S 7W2

U.S. Shipping Address: 88-446 Harrison St, Sumas, WA 98295 U.S. Mailing Address: P.O. Box 231, Sumas, WA 98295

Phone: 604-853-6096 | Fax: 604-853-8749 | Internet: www.bd-power.com

Installation

1. Disconnect the negative battery terminals from both batteries.
2. If utilizing the tire size calibration options you will need to locate the ABS module and connector. To locate the ABS module you will need to remove or pull back the driver side front inner plastic fender well liner. You will need to remove all the mounting bolts and lining press inserts.

2003-2004 Vehicles - ABS Controller Location



When pulling back the fender well lining, be extra careful not to bend the steel fender lip in the process!!!

BD Engine Brake Inc.

Plant Address: 33541 MacLure Rd. Abbotsford, BC, Canada V2S 7W2

U.S. Shipping Address: 88-446 Harrison St, Sumas, WA 98295 U.S. Mailing Address: P.O. Box 231, Sumas, WA 98295

Phone: 604-853-6096 | Fax: 604-853-8749 | Internet: www.bd-power.com

2005-2007 Vehicles - ABS Controller Location

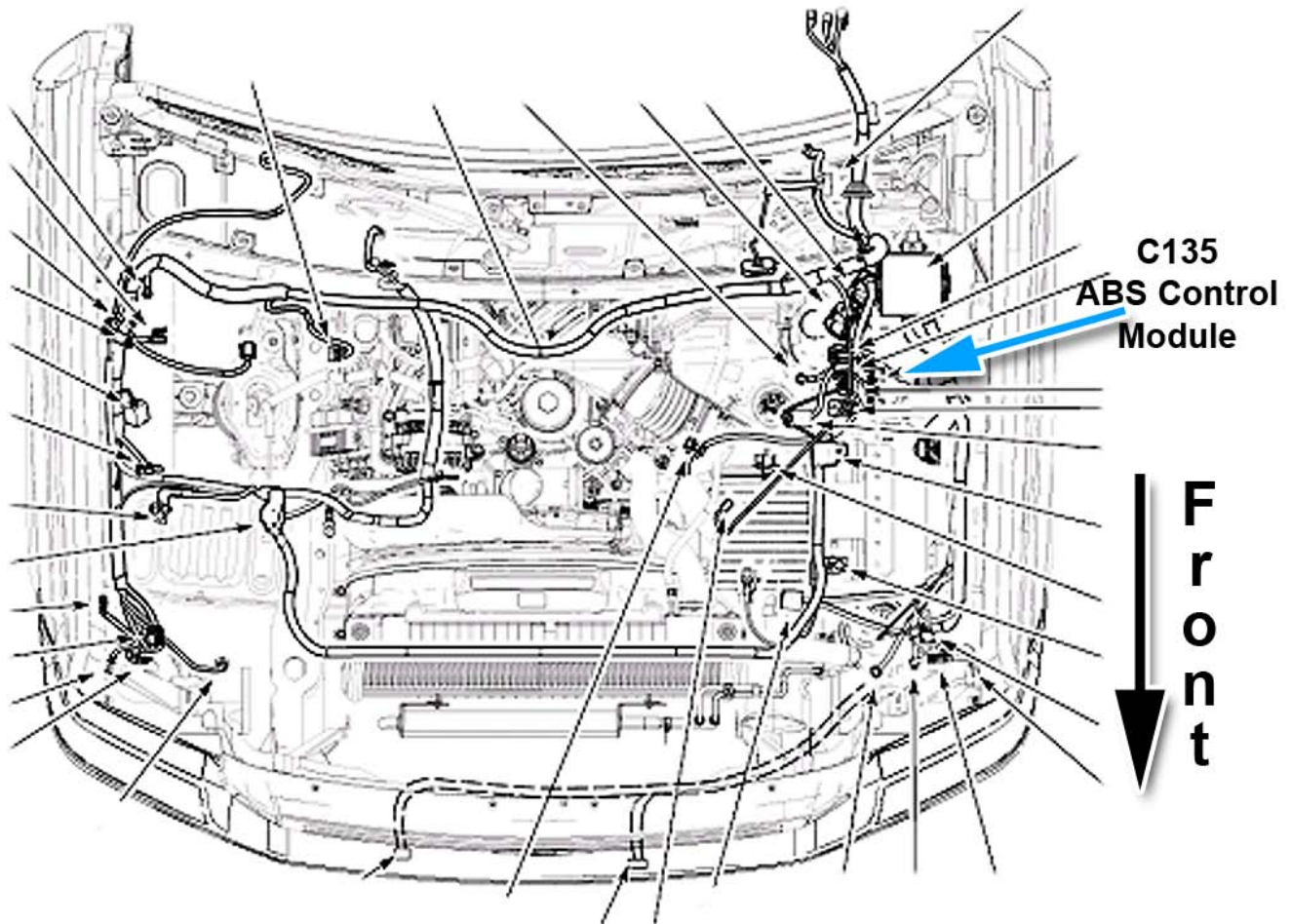

3. Locate the ABS module and quick release plug. Unlock the plug by pushing the locking mechanism towards the center of the vehicle. (The locking handle is located on the inner side of the plug)
4. Locate the Grey w/black tracer wire (2003-04 trucks Pin 11, 2005 trucks Pin #21). You will need to cut this wire and crimp the supplied female bullet connectors in place. You will then need to crimp the supplied wire into place.
5. Attach the supplied yellow wire so that it connects to the Grey w/black wire closest to the ABS connector. The light blue wire should be connected to the Grey w/black wire traveling into the factory loom. Coat the bullet connectors with either dielectric grease or another sealant to keep dirt and moisture out of the contacts.

BD Engine Brake Inc.

Plant Address: 33541 MacLure Rd. Abbotsford, BC, Canada V2S 7W2

U.S. Shipping Address: 88-446 Harrison St, Sumas, WA 98295 U.S. Mailing Address: P.O. Box 231, Sumas, WA 98295

Phone: 604-853-6096 | Fax: 604-853-8749 | Internet: www.bd-power.com

SE Wire Color	Factory Wire Color	Location
Yellow	Grey w/ Black stripe	Coming from ABS Module Harness
Light Blue	Grey w/ Black stripe	Factory Loom to PCM

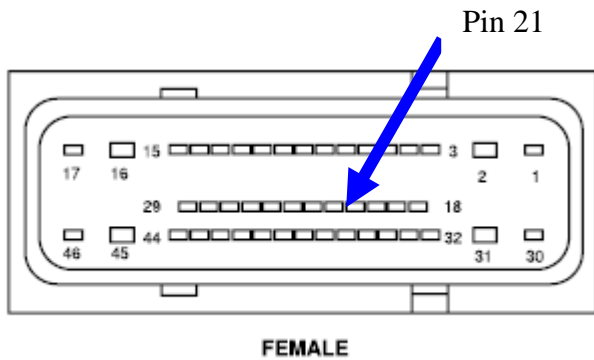
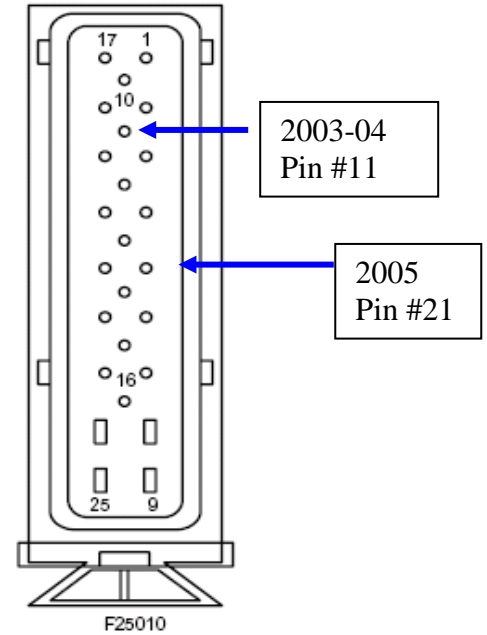

2006 Vehicles
Pin # 21

- Route the yellow and light blue wire straight up through the opening towards the PCM. From there continue on through the firewall.
- You should mount the Speed Eliminator electronic enclosure inside of the cab in a secure location. Route the yellow and light blue wires into the VSS Input and VSS Output green connectors respectively.

Wire	Wire Color
VSS Input	Yellow
VSS Output	Light Blue

8. A fuse tap has been provided for easy access to switched 12 volt power via the fuse panel. You can connect to fuse number 29 (10A) for sufficient keyed power.
9. Route the black ground wire to a clean ground point on the firewall. There are usually many different bolts heads that make excellent ground points. Secure your installation.
10. The Speed Eliminator now has the function to adjust for tire size. You'll notice a small hole on the enclosure with a small potentiometer in side. At the 12 o'clock position, no adjustment is made for tire size. This position is also called stock. Turn the potentiometer with a small blade or Philips screw drive to adjust to the proper vehicle speed. The Speed Eliminator has the ability to adjust the speed up or down +25% or -25%.

If you have stock tires or are not adjusting for tire size, you must ensure that the arrow is exactly vertical.

Note: With the Speed Eliminator installed, the speedometer will stop displaying any speeds over 85 mph, although the truck will continue to accelerate until the engine RPM will governor the vehicle speed.



WELCOME TO OUR CLUB!
BD DISCUSSION FORUMS



Visit our internet forums at <http://www.dieselpower.com> and share your comments or technical support questions with some of the industry's leading experts in the diesel field.

BD Engine Brake Inc.

Plant Address: 33541 MacLure Rd. Abbotsford, BC, Canada V2S 7W2

U.S. Shipping Address: 88-446 Harrison St, Sumas, WA 98295 U.S. Mailing Address: P.O. Box 231, Sumas, WA 98295

Phone: 604-853-6096 | Fax: 604-853-8749 | Internet: www.bd-power.com

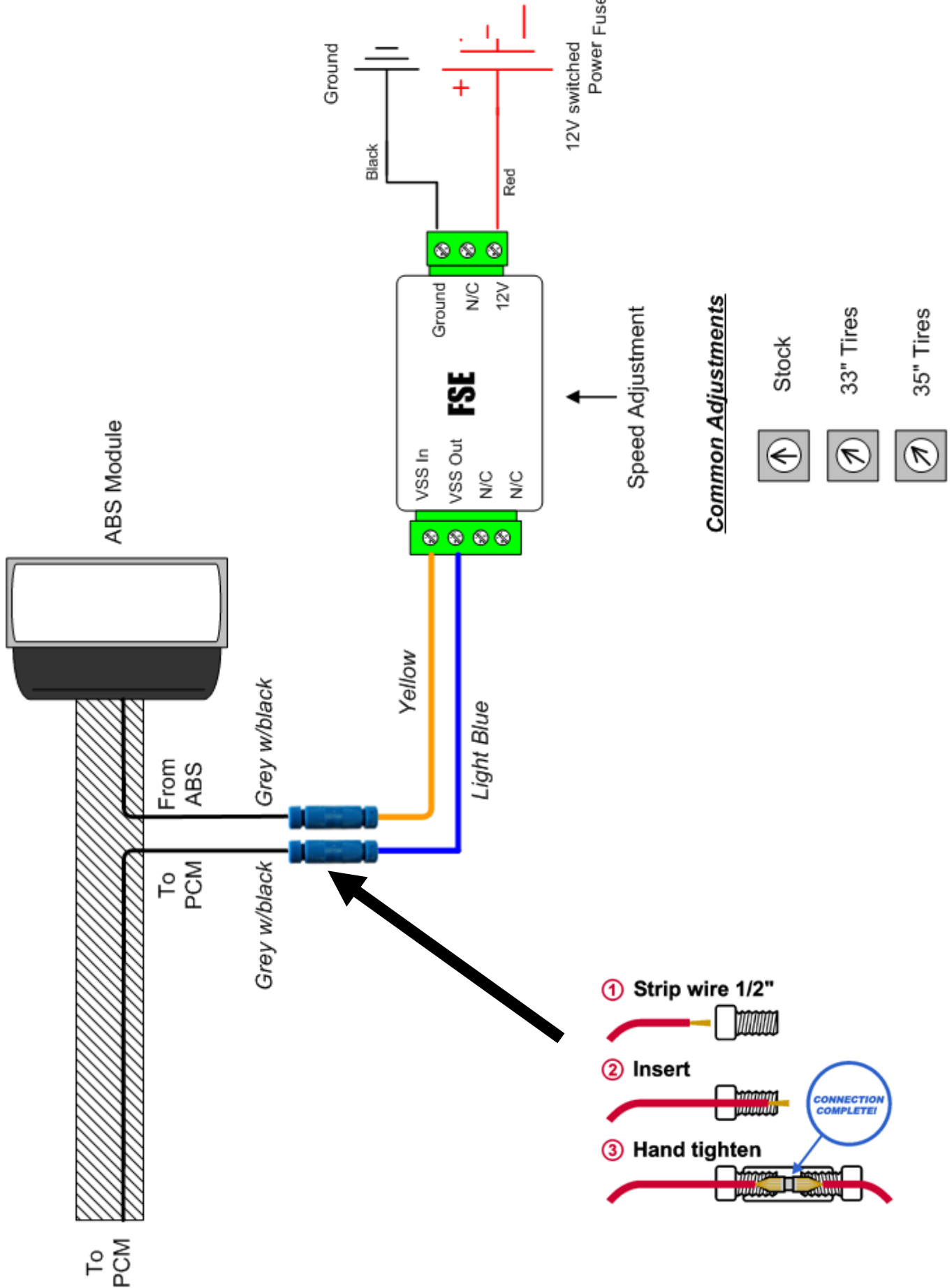

2003-2006+ Installation not utilizing tire size calibration

Note that there have been some compatibility issues with this style of installation on 2005 & 2006 vehicles. If you have problems installing the units please try the installation in the previous section.

If the customer has stock tires and is not going to utilize the tire calibration option, a different installation can be performed. The advantage to this installation is that the speedometer will continue to show vehicle speed past 85 mph. With this installation option the tire size calibrator will not work, although it is still very important that the adjustment screw still be vertical.

1. On the driver's side of the engine compartment, remove the battery cables (ground first) using an 8mm wrench.

2. Remove the battery cover by releasing the tab located on the left side (towards the front of the vehicle) of the battery cover. You may need to use a screwdriver to pry the tab.

3. Disconnect the 2nd of the 3 connectors and pull it around to the right side of the power steering fluid reservoir. This helps free up the 3rd connector.

4. Remove the 3rd connector from the PCM. Locate the gray with black tracer wire in the harness. You will find this connected to **pin 35**.

It is suggested that you cut the electrical tape and open up the black plastic loom surrounding this wire to free up some space. You will need to cut this gray w/black wire in two. Be sure that you have enough length on both ends to attach the supplied Posi-Lock connectors.

5. You must now cut this gray w/black wire and attach the provided bullet connectors. Be careful to attach the

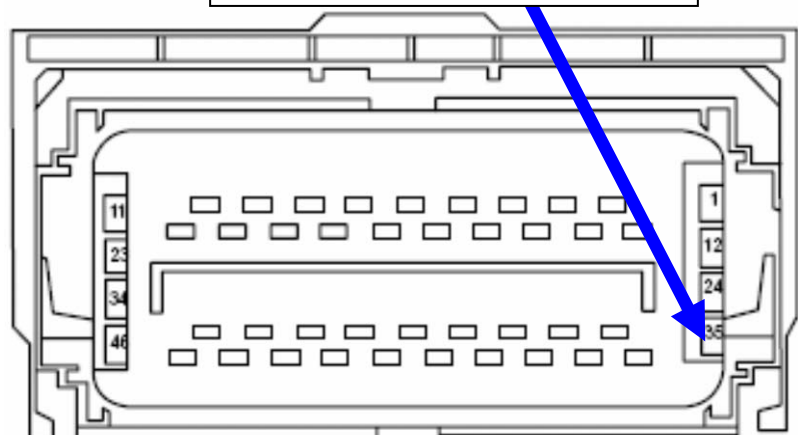
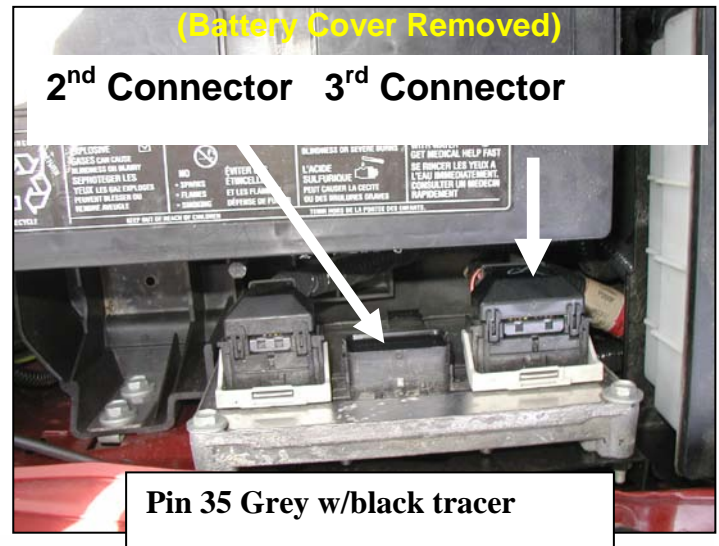

BD Engine Brake Inc.

Plant Address: 33541 MacLure Rd. Abbotsford, BC, Canada V2S 7W2

U.S. Shipping Address: 88-446 Harrison St, Sumas, WA 98295 U.S. Mailing Address: P.O. Box 231, Sumas, WA 98295

Phone: 604-853-6096 | Fax: 604-853-8749 | Internet: www.bd-power.com

right bullet connector to the right side of the wire. Attach the female bullet connector to the gray w/black wire closest to the PCM connector. You will also want to attach the yellow wire to this wire using the male bullet connector. Now attach the other male bullet connector to the other side of the gray w/black wire. Connect the light blue wire to the remaining gray w/black wire using the left over female bullet connector.

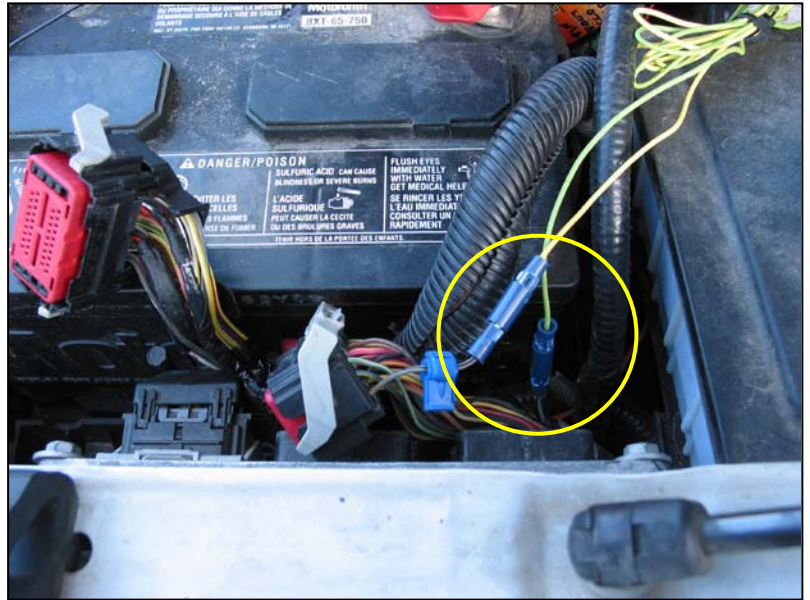

Be sure that the Speed Eliminator VSS OUTPUT is connected to the wire closest to the PCM (connector), while the VSS INPUT should be connected to the wire on the opposite side of the PCM. Once you have finished connecting the bullet connectors you may reconnect the PCM connectors and attach the battery cover.

6. Note that the Speed Eliminator should be mounted inside of the cab, as it is not weather resistant. Route the yellow and light blue wires through the firewall into the cab and connect them to the appropriate input and output connection points. The yellow wire should be connected to the VSS OUTPUT, while the light blue should be connected to the VSS INPUT.

12V Switched power and a clean ground are also needed. Choose one the many grounded mounting bolts underneath the dash for a solid ground point. Switched power can be found through the fuse panel, use the supplied scotch-loc to tap power or the fuse tapper.

Fuse number 29 will supply the keyed power you are looking for.

7. Once you have finished the wiring you can verify your installation with the wiring diagram.

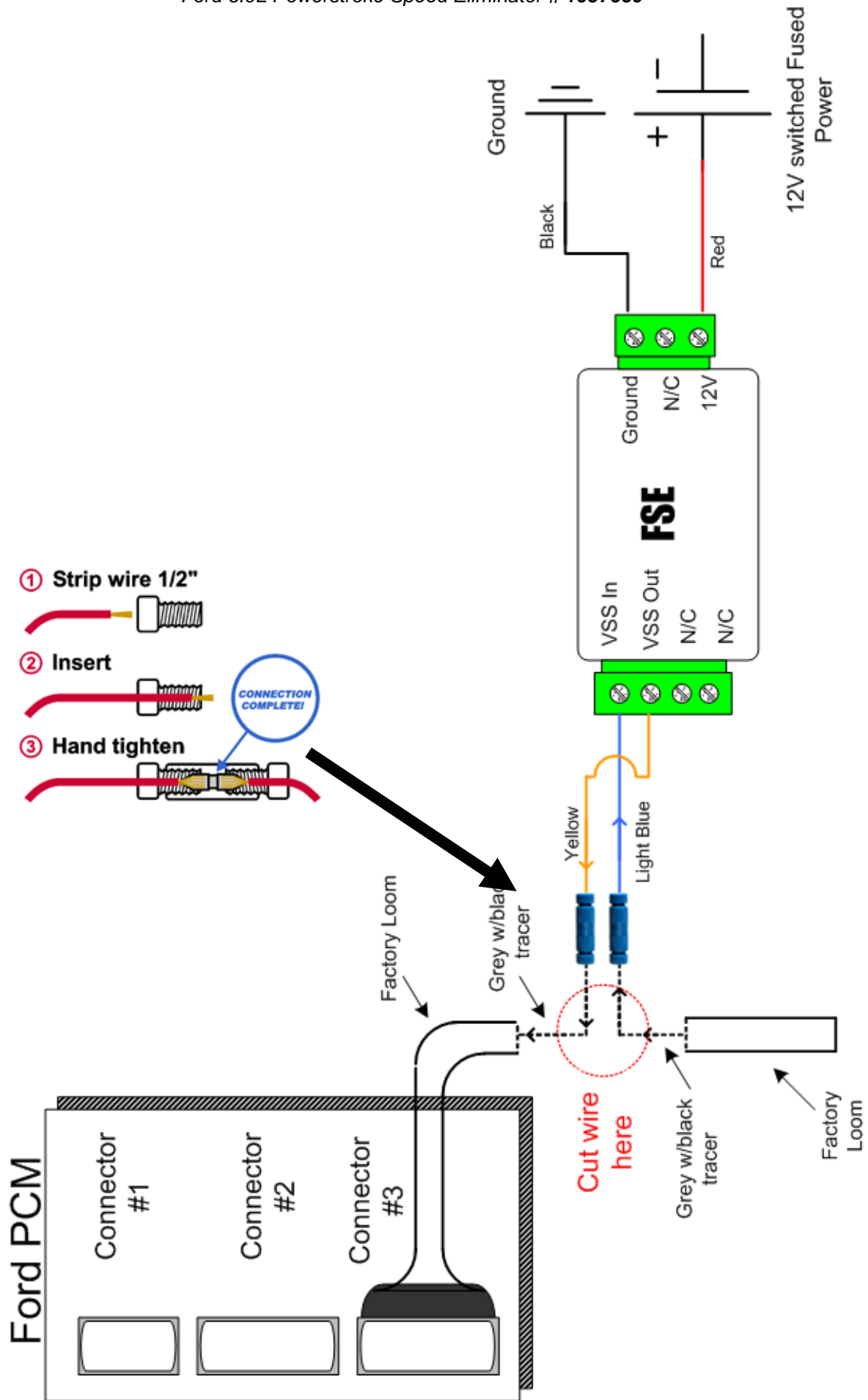

BD Engine Brake Inc.

Plant Address: 33541 MacLure Rd. Abbotsford, BC, Canada V2S 7W2

U.S. Shipping Address: 88-446 Harrison St, Sumas, WA 98295 U.S. Mailing Address: P.O. Box 231, Sumas, WA 98295

Phone: 604-853-6096 | Fax: 604-853-8749 | Internet: www.bd-power.com