



**INSTALLATION
INSTRUCTIONS FOR PART
#50012 WATER/METHANOL
INJECTION SYSTEM
'99 – '03 Ford Powerstroke®
6.0L Diesel**

Contents:

Parts List: 3

Introduction..... 4

Installation Mechanical 4

Testing Pump and Mechanical System 8

Variable Controller Installation 9

Testing the Controller 10

Variable Controller Tuning 10

Controller Operation Example..... 11

Tuning Quick Reference 12

Maintenance 13

Fluid Level Switch (optional)..... 14

Solenoid Upgrade (optional) 15

Install Notes: 16

Disclaimer..... 17

Where to Contact:..... 19



⚠ CAUTION

You must completely read though these instructions before installing and operating this product. Failure to due so can result in damage to this product and the vehicle.

Parts List:

Pump-High pressure/high volume w/ (2) 3/8 elbows
Reservoir
8ft. of Red Tubing
Black Wire Loom
Installation Instructions

Electrical Packet

In small bag:

- 1 Green LED
- 4 Blue Butt Connectors
- 3 Small Eyehook
- 1 Male Connectors
- 3 Female Connector
- 10 Tie Wraps
- armed" switch

VC-100 Controller w/ wiring harness
Vacuum "t"

Mechanical Packet

In small bag:

- 1 nozzle holder
- 7 #8x1&1/2in. Screws
- 7 #8 washers
- 4 #6x1/2in. Screws
- 2 Stickers in Small Plastic Bag

dual nozzle upgrade (nozzle holder,"t", 2' tubing*red
1/8" NPT Tap
extra bulkhead
18" 1/8"tygon tubing
1-375ml/min nozzle
2 625ml/min nozzles

Required tools

- Electric drill w/ drill bits
- Teflon sealant (pipe sealant)
- Adjustable wrench
- Utility knife
- Screw driver – Phillips
- 5/16" open end wrench (for nozzle)

Introduction

- Please refer to the System Diagram below during install. The optional fluid level switch, part #40030, is shown.

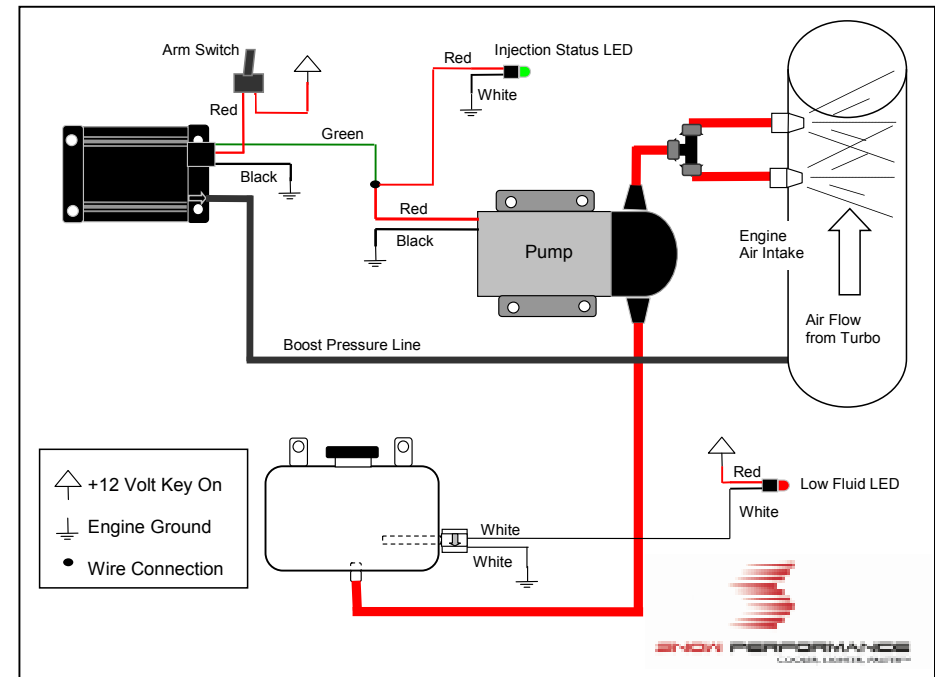

Installation Mechanical

Step 1 Tank Install

Mount tank as high in engine compartment as possible using #8x1½" sheet metal screws and washers provided.



Optional: If windshield washer reservoir is utilized, mount quick-connect bulkhead in the bottom using "Goop" sealant or similar methanol resistant adhesive/sealant.

The following procedure will allow the use of a nut on both sides of bulkhead fitting for windshield washer reservoir:

1. Drill ½” size hole in bottom of reservoir.
2. Attach tubing to threaded end of fitting.
3. Pull tubing through the reservoir fill opening.
4. Slide the nut on the tubing.
5. While pulling on the tube, thread the nut on the fitting after applying sealant.

TECH TIP You can mount the tank in the rear of the vehicle. The pump is a push pump by design so it needs to be mounted as close to the reservoir as possible. Because the pump is oversized, injection pressure will not be affected.

Step 2 Pump Install

To avoid pump housing damage, it is not necessary to turn the 3/8th adaptor fittings all the way in. NPT threads are tapered and with sealant (“Goop” household sealant/adhesive recommended), will usually seal with approx. ½ turn past hand tight. **CAUTION: to over torque the fittings will result in a cracked housing.**



Mount pump so it is positioned at the same level or lower than tank. Pump can be mounted horizontally or vertically using (4) supplied #8x1½” screws and washers.

In cramped engine bays, inside the fender is often a good alternative.

-Measure from reservoir-to- pump inlet (the pump has an arrow indicating flow direction between inlet and outlet ports) and cut ¼”OD red nylon tube to length allowing 1” extra for fittings. Insure no kinks are in the nylon tube. Push tubing into quick-connect fittings 1/4-1/2”.

Mount the check valve between the reservoir and pump inlet. The check valve is marked with an arrow to show flow direction.

Step 3 Nozzle(s) Selection

Nozzle sizing is a function of flywheel horsepower (FWHP), which approximates the engines airflow, and boost, which approximates intake charge heat.

Recommended starting points for 6.0L Powerstroke®:

175 – 250 RWHP	625ml/min nozzle w/ Pump 2 Turns out on set screw.
250 - 300 RWHP:	625ml/min nozzle.
325 - 400 RWHP:	375 & 625ml/min nozzle.
450 - 650 RWHP:	2 - 625ml/min nozzle

TECH TIP When mounting the nozzles, until you are tuned, do not thread lock the nozzle(s) to the nozzle holder. This will allow changing of the nozzles if necessary without damage to the nozzle or holder. Once you are tuned, we recommend thread locking the nozzles to the holder.

- Assemble desired nozzles into nozzles holder using pipe sealant. The end of the nozzle with the 100micron screen is to be inserted into the nozzle holder. Torque at least 1/2 turn past hand tight.

- Note: If nozzles are mounted lower then the reservoir, a solenoid must be used.

- Once tuning is done it is imperative to use permanent thread locker such as loctite 262 to prevent a loose nozzle. Torque the nozzle approx ½ turn clockwise past hand tight using a 5/16” wrench. **CAUTION: to over torque the nozzle will result in reduced nozzle flow.**

- The amount injected can be adjusted by pump pressure which can be changed by turning the allen head in the pump regulator. The pump is set at the factory at 150psi.(2-turns counter clockwise from the 220psi hard stop).

Counterclockwise = Less Pressure.
2-turns Counterclockwise = approx 100psi.
4-turns Counterclockwise = approx 60psi.

Step 4 Nozzle Mounting

The nozzle assembly should be installed at 90 degrees to the direction of airflow. This will ensure maximum cooling as the nozzle sprays in a 180 degree cone pattern. Choose and mark location on air intake for nozzle install.



Drill and tap (11/32" pre-drill, 1/8"-27 NPT tap), metal air inlet tube as close as possible to intake. Remove the cast inlet piece just before the intake and drill and tap for two nozzles.

Step 5 Nozzle Connection

Measure from pump outlet to nozzle and cut red 1/4"OD nylon tubing to desired length and install by pushing tube completely (approx. 1/4-1/2") into quick connect of pump outlet. Connect other end to the "T" fitting. From one outlet of "T" fitting, measure and cut tubing to one nozzle. Repeat for other nozzle. Connect to each nozzle assembly compression fitting by plugging tube into compression fitting (approx. 1/4") and tightening compression nut approx 1/2 turn past hand tight. Check for leaks after initial testing.



TECH TIP The nozzle holder has threads on the outside of it, but we do not recommend mounting the nozzle holder (1/4" npt thread). To eliminate the possibility of the nozzle coming loose and causing possible engine damage, we recommend mounting the 1/8" npt nozzle using the supplied tap.

Use tie wraps to help route tubing and to ensure it doesn't contact moving or hot parts in the engine compartment.

Testing Pump and Mechanical System

- Using a 12v source, apply 12v to the pump red wire (disconnect wire at pump). Pump should activate and fluid level in tank should go down. Also check for leaks.

- If pump goes on but fluid level doesn't go down, there is an obstruction in the tube or nozzle.

- If the pump doesn't go on, there is a ground problem or a faulty pump.

- All pumps are tested before shipment.

- Activation of pump for short periods (2 - 5 sec.) will not cause engine damage.



Variable Controller Installation



The figure above shows the back view of the variable controller.

Mount the variable controller to driver side engine bay using 4 #6x1/2 sheet metal screws (see photo on right)

The VC series controllers are designed to withstand engine bay conditions, but should not be mounted directly to the engine block.



Attach 1/8" hose (supplied) to post on back of controller. The other end attaches to manifold boost source using supplied vacuum "T". Plug wire harness into back of controller. Note the terminal positions are numbered on the bottom side of wire harness connector. Your controller has an internal self resetting fuse such that an external automotive type fuse is not required. In the case of a fault the internal fuse will attempt to reset after about 1 minute.

CAUTION: Disconnect Battery Negative (-) terminal while connecting wires to prevent electrical fire or damage to controller.

- Connect Green wire at position 4 to Pump Red power wire.
- Connect Red wire at position 3 to +12V key on source. When selecting a 12V key-on source, try to find a dedicated circuit with at least a 15 AMP fuse (25 AMP with 220psi pump).
- Connect Black wire at position 1 to a good Ground location.

TECH TIP Always insure to have a good electrical ground connection. Poor ground will result in erratic operation of controller.

Select a location for the LED (green-on when pump activated) in dashboard of vehicle. Run red wire from the connection of the Green controller wire and the Red pump wire to the Red wire of the LED and make connection (refer to wiring diagram). Connect White wire of LED to good ground source under dash.



Mount "armed switch" in dash and wire in the 12Vkey-on-to controller circuit. Do not route wires near hot or moving parts. Use corrugated wire loom and tie wraps (supplied) to protect and route wires.

Testing the Controller

- Begin the testing process with both dials on the variable controller at their lowest settings (counter-clockwise).
- Turn ignition key on so that the system has 12volt power. If the pump runs, inspect ground wires for secure connection.
- Pump should be off at this point, apply light air pressure or blow into vacuum tube connection on back of controller. Pump should active while low pressure is applied but not enough to spray fluid.

Variable Controller Tuning



- Use a tie wrap to keep rubber vacuum/boost line on hose barb in high boost applications.
- With 6.0L Powerstroke®: with 30psi max boost, Start at 20psi / Full at 30psi works well.
- With 35psi max boost, Start at 25psi/ Full at 35psi is a good starting point.
- It is not recommended that "Full" injection take place before 20psig or combustion quench may occur

- Note - over lapping the settings, where the Full dial is lower than Start, will result in max injection at the onset point.
- Adjust Full dial until a smooth power curve is felt with no misfiring.

Controller Operation Example

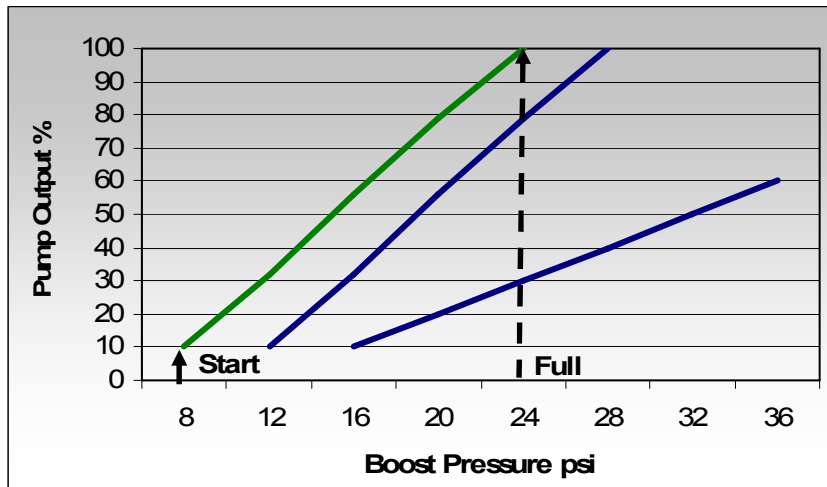

The above chart plots three different settings for the VC-100 water/methanol injection controller

For setting 1, green, the chart shows the Start dial at 8psi and the Full dial at 24psi. At 8psi of boost pressure the pump will operate at 10%. At 24psi of boost pressure, the pump will deliver 100% of injection pressure.

For boost pressure readings between the Start and Full settings, the controller will linearly adjust the pump pressure as shown on the graph.

Tuning Quick Reference

If combustion quench occurs as evidenced by engine “bucking”, reduce the injection quantity or raise the onset boost level. This can be done by:

1. Lowering the pump pressure by turning the pump regulator adjusting screw counterclockwise.
2. Using a smaller nozzle(s).
3. Introducing injection later at a higher boost setting.

Also, fresh methanol – less than 1 month old when exposed to atmosphere – and using a greater methanol concentration – up to 50% - will reduce combustion quench.

100% water will cool combustion and egt’s and will increase power approx 20-30 HP.

75/25% water/methanol will cool egt’s and power will increase approx 40HP.

50/50% water/methanol will cool egt’s and increase power approx 70HP.

Over 50% methanol has been demonstrated to increase egt’s and can cause diesel “knock” in applications with significantly advanced injection timing.

Caution: To avoid “pooling” in the intake and possible engine damage upon start-up, it is recommended that: 1. the engine be run without water/methanol for at least 5 min. after injection before turning the engine off. 2. The “armed switch” is turned to the off position when the engine is off.

Caution: The use of methanol with propane is not recommended due to their similar combustion characteristics. Using both could induce diesel “knock” and cause head gasket problems. For this reason, 100% water is recommended when using this system in conjunction with propane.

Maintenance

Remove nozzle(s) and clean screen filters at least once per year using carb cleaner.

The Boost Cooler® has been designed to operate with high concentrations of methanol. Oil or other additives are not required for system lubrication.

For best performance, cooling and system life it is recommend that Snow Performance Boost Juice™, part #40008, be the exclusive fluid used in the system.

Fluid Level Switch #40030 (optional)

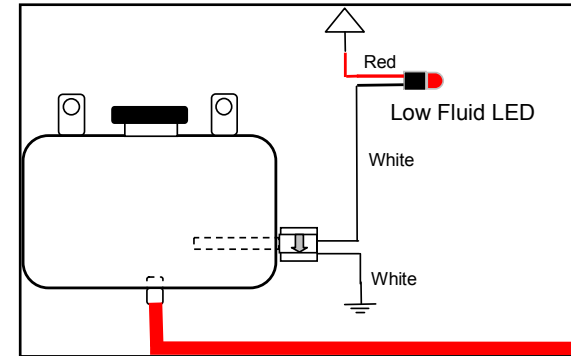

Instructions

- After mounting reservoir, mount red LED in dash next to the green “injection” LED is usually easiest.
- Wire LED per diagram with Red wire to a 12v key-on source, and the White wire to one of the White wires of the level switch.
- Connect other White wire of the level switch to vehicle ground.
- With key-on source enabled, the red LED should be “on” with no fluid in the reservoir. Upon filling the reservoir, the red LED should be “off”.
- The system is designed to indicate when there is less than 1” of fluid in the reservoir.

Solenoid Upgrade (optional)

The optional solenoid upgrade from Snow Performance, part #40060, is required if the fluid reservoir is mounted higher than the nozzle.

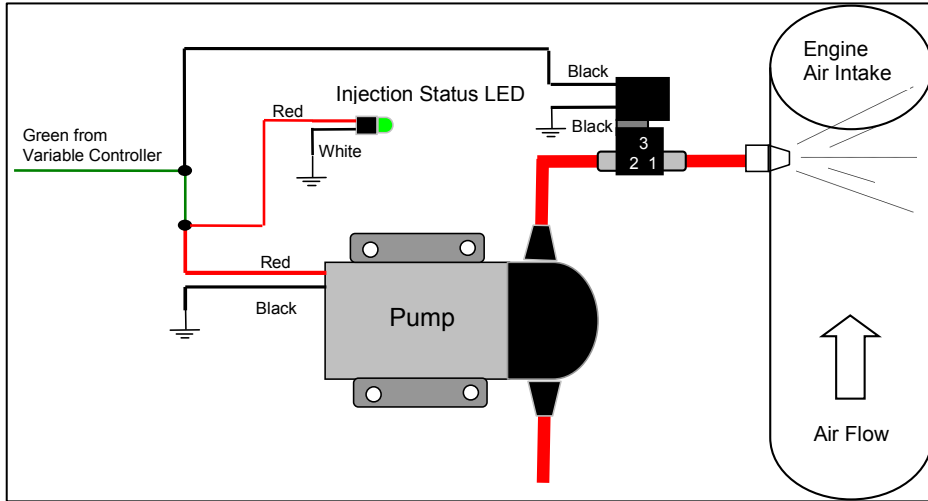

- Hand thread the two 1/8" NPT quick connect fittings into ports labeled 1 and 2 on the solenoid. Tighten an additional half turn.

- Cut high pressure line at location solenoid is to be installed. Insert ends of cut line into quick connect fittings of solenoid. The port labeled #2 is the inlet side, port #1 is the outlet. Firmly pull on line to check secure connection. If line pulls out, re-insert farther into fitting to engage locking clips. If high pressure line removal is required, firmly press in plastic fitting ring to disengage locking clips while pulling hose from fitting.

- Connect one of the Black wires from solenoid to the Red positive pump wire. Note that connecting the wire to any other power source other than the pump wire will result in improper operation of solenoid. Connect the second Black wire to a secure chassis ground location.

Install Notes:

Pump Setting _____ (psi)

Nozzle Size _____ (ml/min)

Controller setting Start: _____

Full: _____

Misc:

Disclaimer

Do not use this product until you have carefully read the following agreement.

This sets forth the terms and conditions for the use of this product. The installation of this product indicates that the BUYER has read and understands this agreement and accepts its terms and conditions.

Performance products by their nature are designed to increase horsepower and performance not engineered in the original vehicle and the increased stress could result in damage to related systems. This is a high performance product – use at your own risk.

Snow Performance Inc., Its agents, employees or owners shall not be under any liability whether in contract or otherwise whether or not resulting from our negligence or contents of information supplied for any damage or loss resulting from such information.

The **BUYER** is responsible to fully understand the capability and limitations of his/her vehicle according to manufacturer specifications and agrees to hold the **SELLER** harmless from any damage resulting from failure to adhere to such specifications.

The **SELLER** disclaims any warranty and expressly disclaims any liability for personal injury or damages. The **BUYER** acknowledges and agrees that the disclaimer of any liability for personal injury is a material term for this agreement and the **BUYER** agrees to indemnify the **SELLER** and to hold the **SELLER** harmless from any claim related to the item of the equipment purchased. Under no circumstances will the **SELLER** be liable for any damages or expenses by reason of use or sale of any such equipment.

The **BUYER** is responsible to obey all applicable federal, state, and local laws, statutes, and ordinances when operating his/her vehicle, and the **BUYER** agrees to hold **SELLER** harmless from any violation thereof.

The **SELLER** assumes no liability regarding the improper installation or misapplication of its products.

It is the installer's responsibility to check for proper installation and if in doubt, contact the manufacturer.

LIFETIME WARRANTY

Snow Performance's commitment to providing the best water/methanol system is reflected in the Lifetime Warranty that is standard on all Snow Performance Boost Coolers™. We are able to offer this warranty due to our control of manufacturing quality and the historically high reliability of our products in the field.

Warranty Policy

Snow Performance, Inc. (hereafter "Snow") warrants that the Product shall conform to and perform in accordance with published technical specifications and shall be free of defects in materials and workmanship as long as :

The exclusive fluid used in the kit has been Snow performance's Boost Juice™ water methanol product as evidenced by sales receipts confirming purchases.

In the event that Boost Juice has not exclusively been used, A One Year Warranty applies.

In the event of failure, Snow will repair or replace the part at Snow's sole discretion. Failures resulting from misapplication or misuse of the Product, failure to adhere to any specifications or instructions, or failure resulting from neglect, abuse, accidents, or acts of nature are not covered under this warranty.

Warranty service may be obtained by delivering the part to Snow and providing proof of purchase. Customer agrees to insure the Product or assume the risk of loss or damage in transit, to prepay shipping charges to Snow, and to use the original shipping container or equivalent. Warranty is valid only for original purchaser and is not transferable. This Warranty gives you specific legal rights, and you may also have other rights which may vary from state to state.

This warranty applies to Snow manufactured Boost Cooler™ kits.

Non-Warranty Repair/Retest

Products returned due to damage or misuse and Products retested with no problem found are subject to repair/retest charges. A purchase order or credit card number and authorization must be provided in order to obtain an RMA (Return Merchandise Authorization) number prior to returning Product.

Where to Contact:

<http://www.snowperformance.net>

Sales (719) 633-3811, Toll Free (866) 365-2762

Tech Support Line (540) 760-3384

FAQ and Technical Forum: <http://www.snowperformance.net/forum/>

Snow Performance, Inc.

2205 Valley View Dr.

Woodland Park, CO 80863

Notes

The contents of this document are subject to change without prior notice. No part of or this entire document may be reproduced in any form without prior written permission of Snow Performance, Inc under the copyright except for private use.

The names, addresses and telephone numbers mentioned are current as of December 1, 2005. Note that this information is subject to change. Please refer to www.snowperformance.net for current information.