



Flow-Max^{V2}

BD's Revolutionary New Heavy-Duty Lift Pump System

**1998½-2004 5.9L DODGE CUMMINS
RETRO FIT INTAKE PUMP Kit**



Installation Instructions

P/N# 1050302

PLEASE READ ALL INSTRUCTIONS CAREFULLY BEFORE INSTALLATION.

The BD auxiliary lift pump kit will provide the safety and performance of enhanced fuel flow to your Cummins engine.

Kit Contents

| 1502021 | 1505001 |
|---|--|
|  |  |
| <p align="center"><i>3/8 Fuel Hose</i></p> | <p align="center"><i>Hose Clamp</i></p> |
| <p align="center">Qty: 8"</p> | <p align="center">Qty: 3</p> |

***** The filter to be used as the in-take filter has been included in your FlowMax fuel pump kit.***

Required Tools

- Razor Blade/Knife
- Pliers
- 3/16" Flat Screwdriver
- 10 mm Socket or wrench

BD Engine Brake Inc.

Plant Address: 33541 MacLure Rd. Abbotsford, BC, Canada V2S 7W2

U.S. Shipping Address: 88-446 Harrison St, Sumas, WA 98295 U.S. Mailing Address: P.O. Box 231, Sumas, WA 98295

Phone: 604-853-6096 | Fax: 604-853-8749 | Internet: www.bd-power.com

Installation

Continue to follow the normal pump installation instructions that come with your FlowMax Pump kit. Instead of removing the factory lift pump from its factory location, you will need to remove the aluminum spacer blocker where your OEM pump once existed, along with the hard lines and wiring harness.

The retrofit effectively removes the unsatisfactory upgraded pump from inside the filter bowl. While still pulling fuel from the filter bowl, which reductions fuel slosh and running out of fuel prematurely.

Raise the vehicle and support it safely.

You will now need to drop the factory fuel tank. **Be very careful as a full fuel tank is very heavy.**

- a. Use a transmission jack or something similar to support the fuel tank.
- b. Locate the support straps that secure the fuel tank to the vehicle. Loosen these and remove.
- c. With the tank loose, reach up on top of the tank and un-clip and remove the factory fuel line quick connects.
- d. Lower the fuel tank.



BD Engine Brake Inc.

Plant Address: 33541 MacLure Rd. Abbotsford, BC, Canada V2S 7W2

U.S. Shipping Address: 88-446 Harrison St, Sumas, WA 98295 U.S. Mailing Address: P.O. Box 231, Sumas, WA 98295

Phone: 604-853-6096 | Fax: 604-853-8749 | Internet: www.bd-power.com

Rotate the locking clip that secures the basket to the fuel tank.

Remove the factory pickup can/basket from the top of the tank.



With the basket removed, use a hack saw blade and cut the three supports from the OE lift pump.

Disconnect the factory power and ground wires from the pump. Tie these out of the way.

DO NOT USE A ZIP TIE AS IT WILL DISENGRATE IN THE DIESEL FUEL.

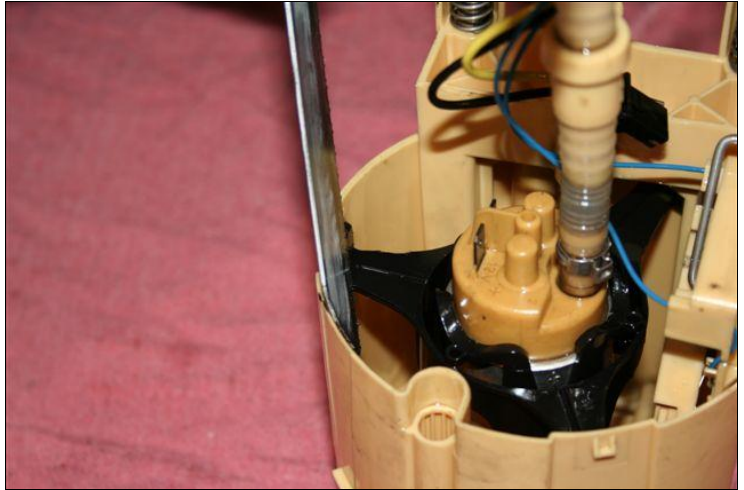

Release the two locking clips that secure the float with a flat head screwdriver.

With the float out, you should have more room to work.

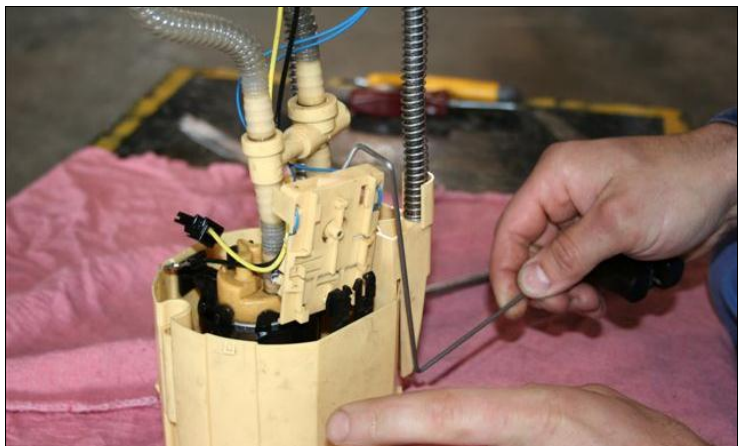
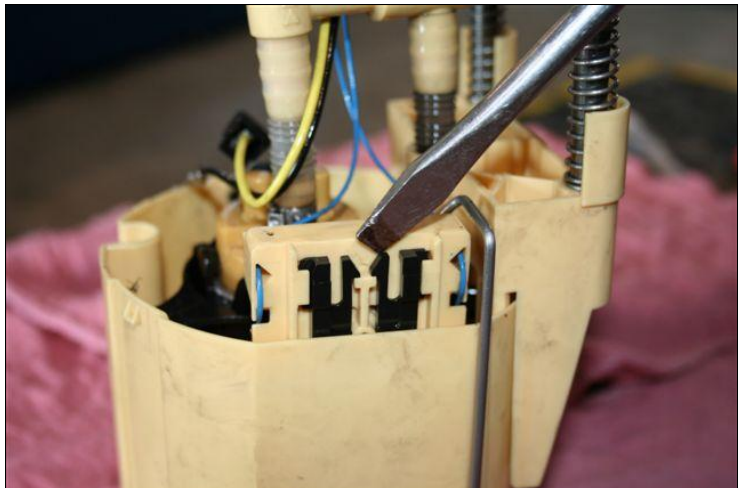

BD Engine Brake Inc.

Plant Address: 33541 MacLure Rd. Abbotsford, BC, Canada V2S 7W2

U.S. Shipping Address: 88-446 Harrison St, Sumas, WA 98295 U.S. Mailing Address: P.O. Box 231, Sumas, WA 98295

Phone: 604-853-6096 | Fax: 604-853-8749 | Internet: www.bd-power.com

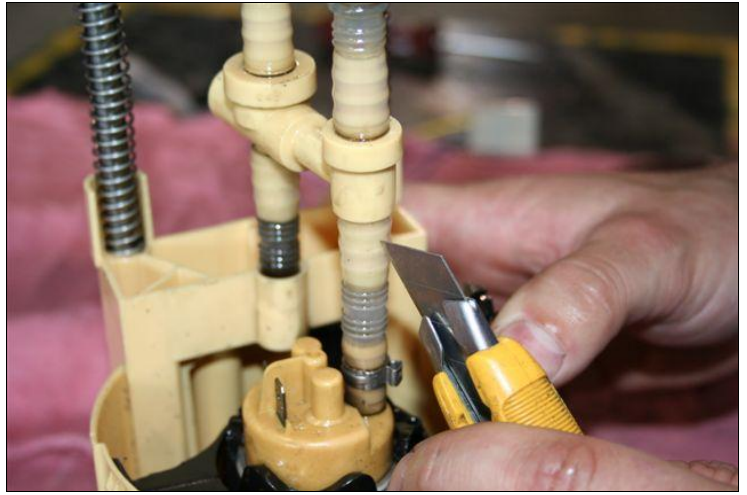

With a sharp knife, score the plastic tube to release the outer tube and expose the 3/8" barb.

You should now be able to lift the OE pump out of the basket.

DO NOT CUT INTO THE PLASTIC BARB.



BD Engine Brake Inc.

Plant Address: 33541 MacLure Rd. Abbotsford, BC, Canada V2S 7W2

U.S. Shipping Address: 88-446 Harrison St, Sumas, WA 98295 U.S. Mailing Address: P.O. Box 231, Sumas, WA 98295

Phone: 604-853-6096 | Fax: 604-853-8749 | Internet: www.bd-power.com

Use the supplied 3/8" hose and stainless hose clamp to attach the hose to the 3/8" barb.

You will need to trim the hose to the exact length so it sits flush with the bottom of the basket.

BE SURE TO CUT THE HOSE AT AN ANGLE OR V-NOTCH THE BOTTOM, OTHERWISE THE HOSE WILL SUCTION TO THE BOTTOM OF THE BASKET.

IF YOU CUT THE V-NOTCH TOO HIGH, THE TRUCK MAY RUN OUT OF FUEL PREMATURELY.

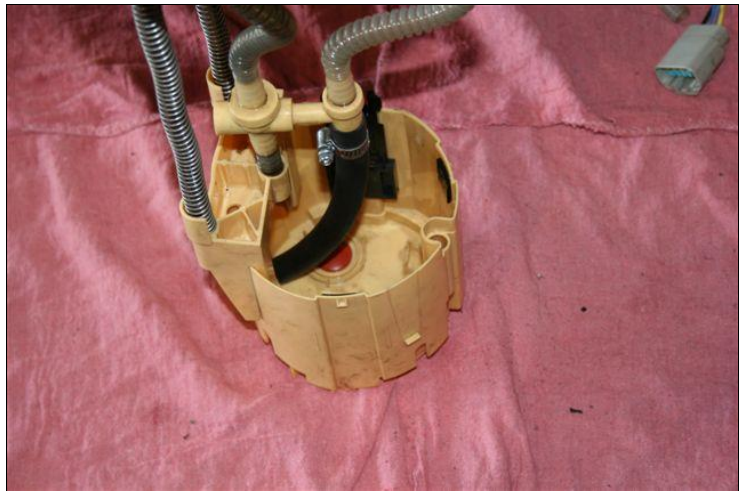

Re-attach the float.

Drop the modified basket into the fuel tank and secure with the locking ring.

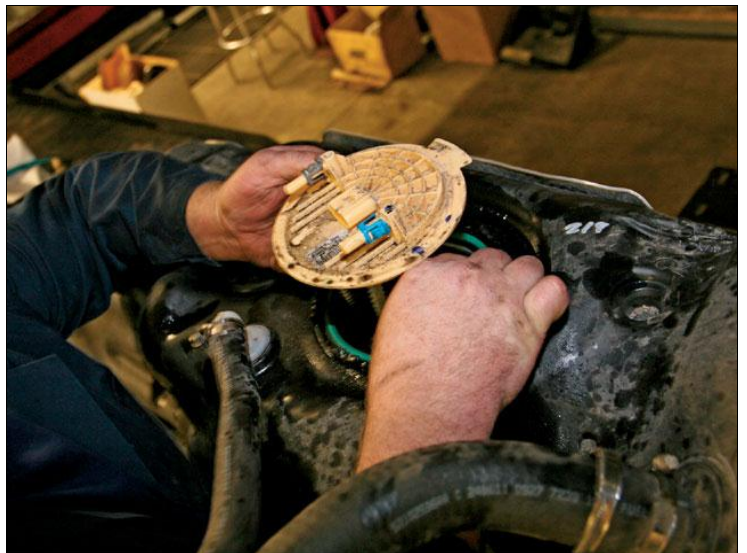

BD Engine Brake Inc.

Plant Address: 33541 MacLure Rd. Abbotsford, BC, Canada V2S 7W2

U.S. Shipping Address: 88-446 Harrison St, Sumas, WA 98295 U.S. Mailing Address: P.O. Box 231, Sumas, WA 98295

Phone: 604-853-6096 | Fax: 604-853-8749 | Internet: www.bd-power.com

Raise fuel tank back up into vehicle and reconnect all connections. Secure the tank to the vehicle.



Locate fuel supply line from the tank that travels into the FlowMAX pump. Make a cut in this fuel hose and insert the fuel screen.

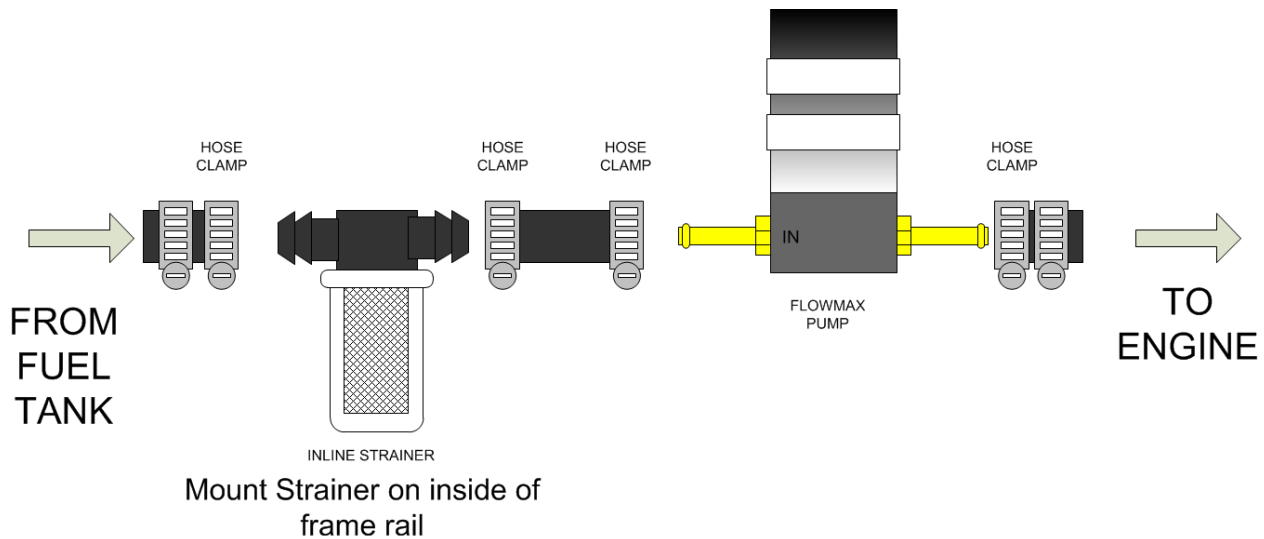

If you experience any problems or difficulties with this kit, please contact the BD Technical Department at 1-604-853-6096 or fax at 1-604-853-8749, between 8:00am and 4:30pm Pacific Time.

Troubleshooting

Wiring Harness Diagram

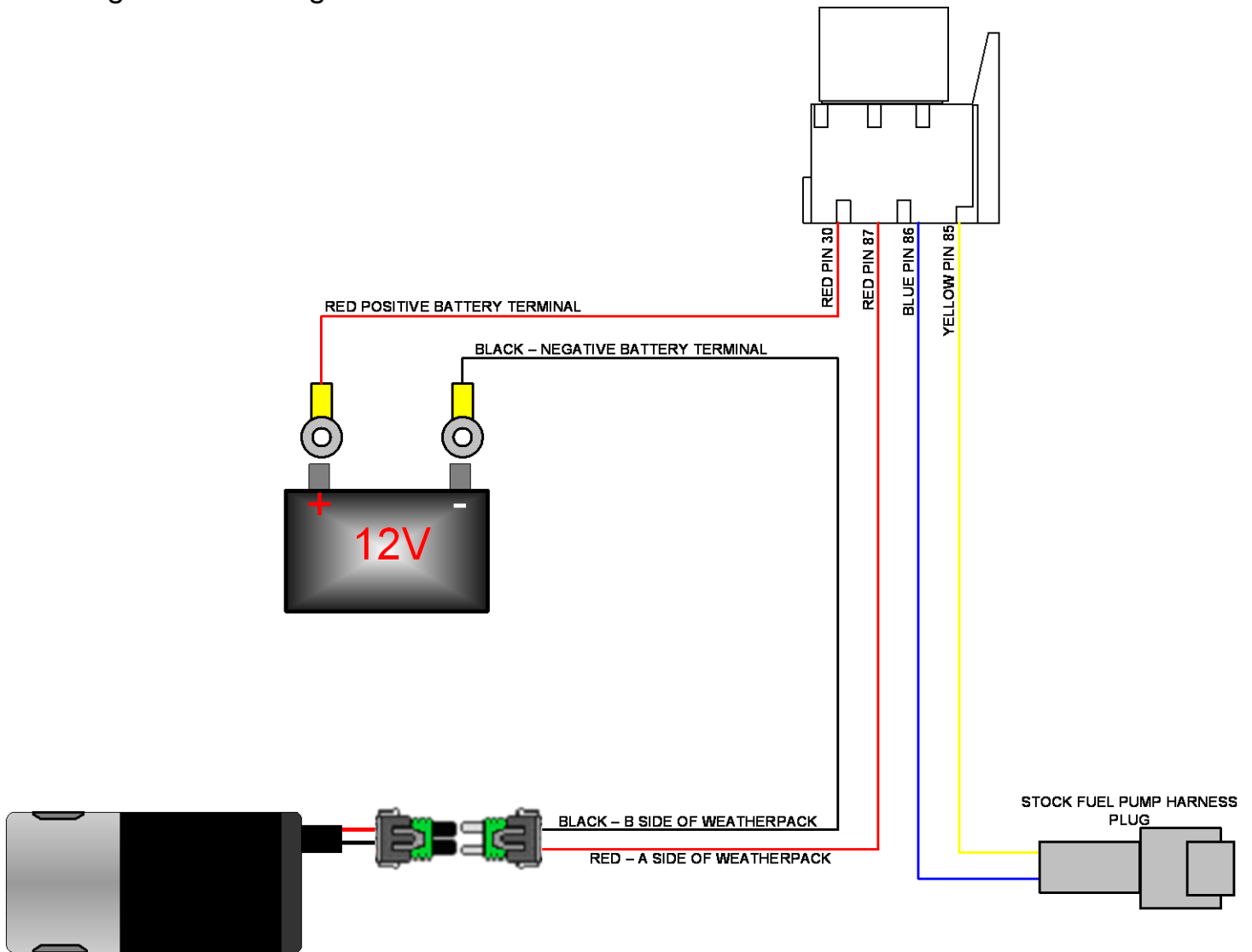

If you have problems, complete the following tests or procedures,

- Clean and re-tighten battery terminals.
- Ensure there are no crimped/pinched sections of fuel line.
- Change Fuel Filter
- Check that you have at least 12 volts at the electrical connector at the pump.
- Check that fuse in supplied harness near battery terminal is not blown.
- Check that all plugs are securely clipped together
- Run a hose from a fuel can full of diesel to the pump inlet to see if the pressure changes.

If the pressure increases the problem is a restriction in the line possibly a clogged fuel screen.

The pump should operate between 16 and 18psi with 14V at idle. If you have lower voltage the pump pressure will also be lower.

BD Engine Brake Inc.

Plant Address: 33541 MacLure Rd. Abbotsford, BC, Canada V2S 7W2

U.S. Shipping Address: 88-446 Harrison St, Sumas, WA 98295 U.S. Mailing Address: P.O. Box 231, Sumas, WA 98295

Phone: 604-853-6096 | Fax: 604-853-8749 | Internet: www.bd-power.com