



1998-2002 DODGE CUMMINS 24V ISB *OEM BYPASS LIFT PUMP KIT*

Installation Instructions

P/N# 1050229

PLEASE READ ALL INSTRUCTIONS CAREFULLY BEFORE INSTALLATION.











BD Engine Brake Inc.

Plant Address: 33541 MacLure Rd. Abbotsford, BC, Canada V2S 7W2

U.S. Shipping Address: 88-446 Harrison St, Sumas, WA 98295 U.S. Mailing Address: P.O. Box 231, Sumas, WA 98295

Phone: 604-853-6096 | Fax: 604-853-8749 | Internet: www.bd-power.com

Kit Contents

 <p>P4601HP</p>	 <p>1100111</p>	 <p>1230116</p>	 <p>1300131</p>
<p>Lift Pump Assy. Qty: 1</p>	<p>Flat Washer Qty: 6</p>	<p>NyLock Nut Qty: 6</p>	<p>Tie Wrap (Medium) Qty: 5</p>
 <p>1300220</p>	 <p>1505001</p>	 <p>1400120</p>	 <p>1502021</p>
<p>Anti-Vibration Mount Qty: 3</p>	<p>Hose Clamp Qty: 5</p>	<p>3/8" NPT x 3/8" PO Fitting Qty: 2</p>	<p>Fuel Hose Qty: 2 (1 x 25" / 1 x 60")</p>
 <p>1502027</p>	 <p>1502033</p>		 <p>1502034</p>
<p>Lift Pump Harness Qty:1</p>	<p>M12 x -8 JICM Adapter Qty: 1</p>		<p>-8 JICF x 3/8" 90° ADAPTER Qty: 1</p>

BD Engine Brake Inc.

Plant Address: 33541 MacLure Rd. Abbotsford, BC, Canada V2S 7W2

U.S. Shipping Address: 88-446 Harrison St, Sumas, WA 98295 U.S. Mailing Address: P.O. Box 231, Sumas, WA 98295

Phone: 604-853-6096 | Fax: 604-853-8749 | Internet: www.bd-power.com

Additional Parts Included with Kit

- **Electrical contact Nut (2)**
- **Isolator nuts (3)**
- **Isolator washers (3)**
- **Isolators (3)**
- **Gear Clamp (3)**



Discard bag and contents once unit is installed.

**Before You Begin**

This pump kit is designed to be a stand-alone system and is not designed to be used in conjunction with stock lift pumps. If your truck has been retrofitted with the Chrysler in-tank lift pump you will have to lower the fuel tank & delete the pump from in the tank. BD offers a simple retrofit kit complete with instructions & the pieces needed to do this, part number 1050302. If you are unsure if your truck has been retrofitted simply check that the factory lift pump is still in place on the engine next to the fuel filter housing (see diagram below); if it is not there then your truck has the in-tank pump.

BD Engine Brake Inc.

Plant Address: 33541 MacLure Rd. Abbotsford, BC, Canada V2S 7W2

U.S. Shipping Address: 88-446 Harrison St, Sumas, WA 98295 U.S. Mailing Address: P.O. Box 231, Sumas, WA 98295

Phone: 604-853-6096 | Fax: 604-853-8749 | Internet: www.bd-power.com

Optional Accessories:

- **1081130** - Low Fuel Pressure LED Alarm kit
- **1085210** – X-Monitor Digital Gauge Package
- **1080156** – Fuel Pressure Kit (X-Monitor Accessory)

Installation:

1. Disconnect both batteries.
2. Raise the vehicle and support it safely.
3. Locate and remove the factory lift pump and all connecting lines. You will need to disconnect the fuel line connecting to the lift pump as well as the fuel line that travels from the lift pump the fuel filter. Note that you will not be able to fully remove the fuel supply line to the pump yet as you will need to cut the existing fuel line. This step is outline in the next section.

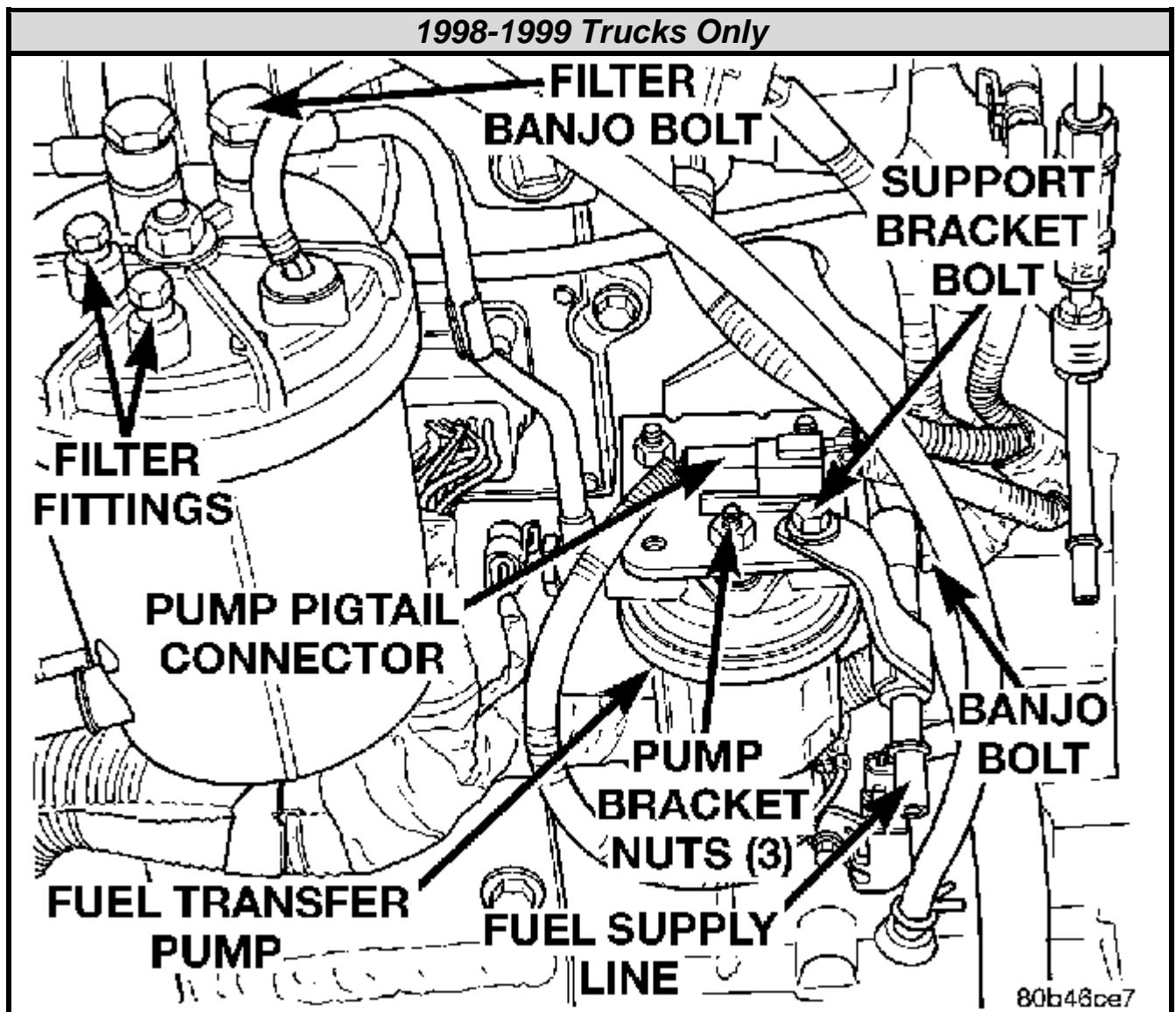

BD Engine Brake Inc.

Plant Address: 33541 MacLure Rd. Abbotsford, BC, Canada V2S 7W2

U.S. Shipping Address: 88-446 Harrison St, Sumas, WA 98295 U.S. Mailing Address: P.O. Box 231, Sumas, WA 98295

Phone: 604-853-6096 | Fax: 604-853-8749 | Internet: www.bd-power.com

2000-2002 Trucks Only

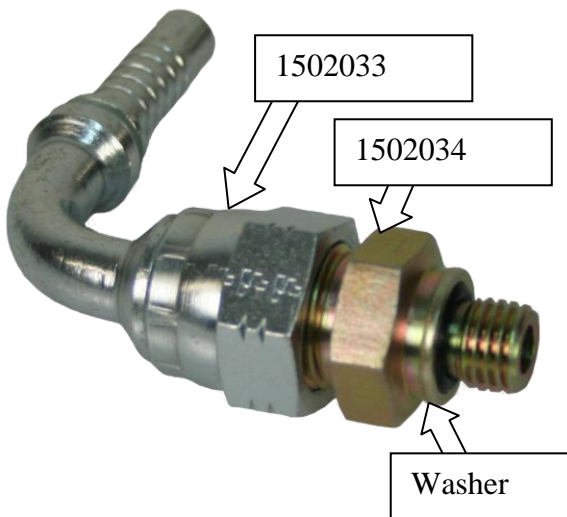
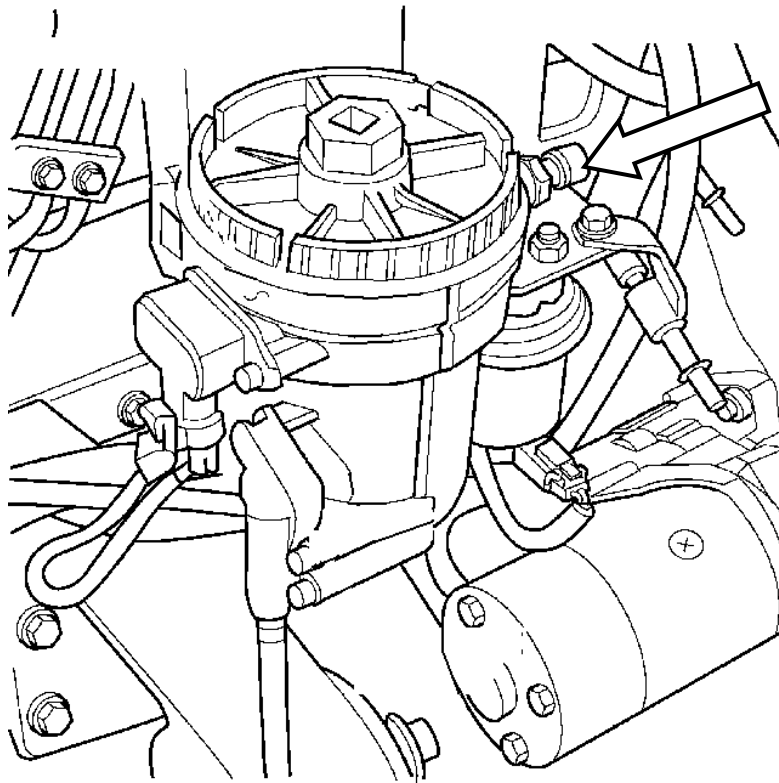

4. Thread the JICM adapter (1502033) into the fuel filter housing where the banjo bolt was removed and tighten first. Do not over-torque as this is an o-ring seal. Then thread on the JICF adapter (1502034) position the barbed end and tighten.

1998-99	Top of filter housing
2000-02	Rear of filter housing

Note the JICM adapter has a loose washer around the oring ensure this does not fall off the adapter during installation.

5. Connect fuel line extension hose to the adapter fitting. Make sure that by re-routing the hose it doesn't rub on anything. This hose should be routed along the same path as the factory fuel line once did. Once the pump installation is completed this fuel line hose will be connected to the "OUT" port of the replacement pump.

BD Engine Brake Inc.

Plant Address: 33541 MacLure Rd. Abbotsford, BC, Canada V2S 7W2

U.S. Shipping Address: 88-446 Harrison St, Sumas, WA 98295 U.S. Mailing Address: P.O. Box 231, Sumas, WA 98295

Phone: 604-853-6096 | Fax: 604-853-8749 | Internet: www.bd-power.com

Pump Installation

6. Locate a spot on the driver's side frame rail near the frame opening so you can get the nuts and lock washers onto the back of the rubber isolators. Alternately if you cannot get to the backside frame to install the lock washers and nuts, you can drill and tap the holes to ¼ NC (drill bit #7 or 13/64") for mounting the rubber isolators. If you choose this method be sure to use Loc-tite on the threads.

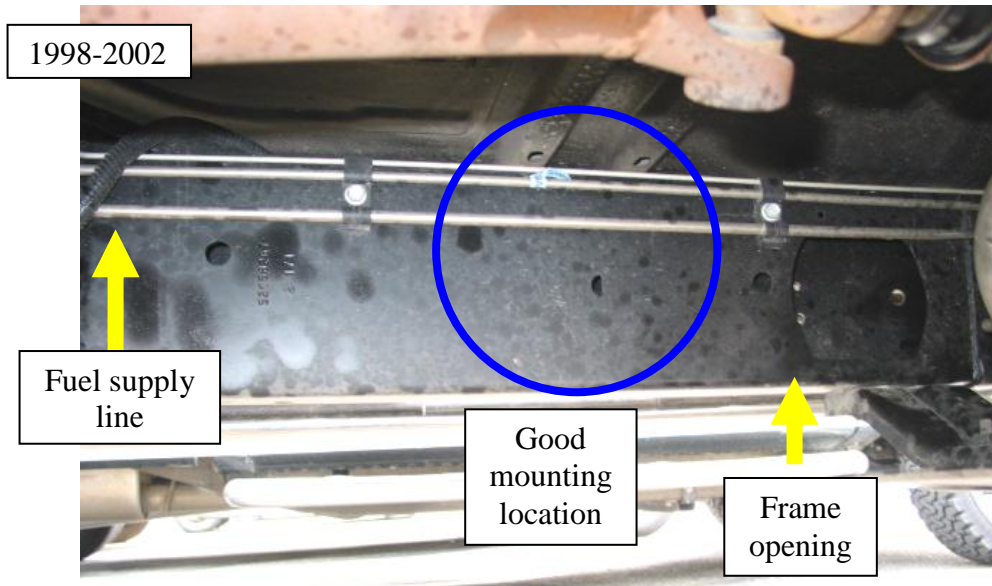

7. Cut the steel fuel supply line and remove a 14" section, centered on the location you chose to mount the mounting at. A pipe cutter is strongly recommended to cut the line, be sure not to squish or compress the fuel line, and remove any burrs that are left over from the process. Note that the front section of the cut fuel line should be completely removed as it will be replaced with fuel line hose.



Lift Pump Bracket

8. Using the pump bracket as a template, mark the three hole locations as shown and drill to 1/4". If you cannot access the rear of the frame rail you will need to drill and tap the three holes. Use drill bit #7 or 13/64, then tap to ¼" NC.
9. Install the three rubber isolators with the long threaded end through the frame. Be sure to use Loc-tite if you are threading the isolators into the frame.

10. Install the pump bracket on to the three rubber isolators with the supplied nuts and lock washers (These parts are found inside the sealed bag inside the pump box). Mount the pump to the "L" bracket with the supplied isolators and bolts. The pump is marked inlet and outlet so be sure that the outlet is pointed of the front the front of the vehicle.

11. Install the two brass fittings in the pump - Do not use any thread sealant as this may void the warranty of the pump.

BD Engine Brake Inc.

Plant Address: 33541 MacLure Rd. Abbotsford, BC, Canada V2S 7W2

U.S. Shipping Address: 88-446 Harrison St, Sumas, WA 98295 U.S. Mailing Address: P.O. Box 231, Sumas, WA 98295

Phone: 604-853-6096 | Fax: 604-853-8749 | Internet: www.bd-power.com

12. Install the two pieces of rubber fuel lines with one clamp on each barb fitting and two on the steel line. Tighten the hose clamps on the factory fuel line and the brass-barbed fittings.



13. Connect the wiring harness to the pump (red [+], black [-]) and run it to engine compartment along the left frame rail, securing it along the way with the provided zip ties. Then attach the harness to the factory lift pump connector on the drivers side of the engine. Coat the lift pump connections with some type of anti-seize, silicone, or battery terminal paint to protect them against corrosion.
14. Reconnect the batteries and reset the radio station presets.
15. Start your engine, and verify that your auxiliary pump starts when your oil pressure builds up. Check for fuel and oil leaks at the various connections made during the installation. It is also recommended that you monitor the fuel pressure initial to ensure proper operation. Typically fuel pressure at idle should be around 10-12 psi.

If you experience any problems or difficulties with this kit, please contact the BD Technical Department at 1-604-853-6096 or fax at 1-604-853-8749, between 8:00am and 4:30pm Pacific Time.

BD Engine Brake Inc.

Plant Address: 33541 MacLure Rd. Abbotsford, BC, Canada V2S 7W2

U.S. Shipping Address: 88-446 Harrison St, Sumas, WA 98295 U.S. Mailing Address: P.O. Box 231, Sumas, WA 98295

Phone: 604-853-6096 | Fax: 604-853-8749 | Internet: www.bd-power.com