



****ATTENTION****
You must pre-lube the turbocharger before installation. Failure to do so will void the warranty.



FORD 7.3L TURBO THRUSTER

1999.5-2003 Ford Powerstroke F250-350





Part# 1047510



PLEASE READ ALL INSTRUCTIONS BEFORE INSTALLATION

UNLESS AN EO# IS LISTED, THIS PRODUCT IS LEGAL IN CALIFORNIA FOR RACING VEHICLES ONLY, WHICH MAY NEVER BE USED UPON A HIGHWAY.

KIT CONTENTS:

Please check to make sure that you have all the parts listed in this kit before you start the disassembly of your truck.

FORD 1995.5-2003 7.3L TURBO KIT (BD# 1047510)			
1407505	1407018	1407017	8-A-1520
			
<i>7.3L Turbo Thruster</i>	<i>Inlet Clamp</i>	<i>GTP38 Inlet Hose</i>	<i>Bolts, 12 Point</i>
Qty: 1	Qty: 1	Qty: 1	Qty: 7

1407343	1407344	234-ORING
		
<i>Inlet Oring</i>	<i>Oil Out Oring</i>	<i>Outlet Oring</i>
Qty: 2	Qty: 2	Qty: 1

Pre-Installation Notes

A turbocharger is driven solely on exhaust energy. Therefore, if the vehicles current exhaust manifold is cracked or is leaking, it is recommended that the exhaust manifolds are checked by a reputable machine shop.

Installation should occur on a cold vehicle, as turbo and exhaust components become very hot with use.

To prelube the turbocharger, squirt some oil into the oil feed inlet. Rotate the compressor or turbine wheel to ensure the oil coats all around the bearing and shaft. Once complete the turbo is ready to be installed.

Upgrade Options

Description	Part #
BD X2 Digital Gauge Monitor	1080500
BD Cool Down Timer	1081160
ARP Head Studs	250-4201 (1999-2003 Only)
Charge Air Cooler	1042700
Stainless Exhaust Kit	1049701D (1999-2003 Only)

BD Engine Brake Inc.

Plant Address: 33541 MacLure Rd. Abbotsford, BC, Canada V2S 7W2

U.S. Shipping Address: 88-446 Harrison St, Sumas, WA 98295 U.S. Mailing Address: P.O. Box 231, Sumas, WA 98295

Phone: 604-853-6096 | Fax: 604-853-8749 | Internet: www.bd-power.com

BATTERY DISCONNECT

Disconnect the negative terminals on both of the vehicle's batteries, and then disconnect the positive terminals.

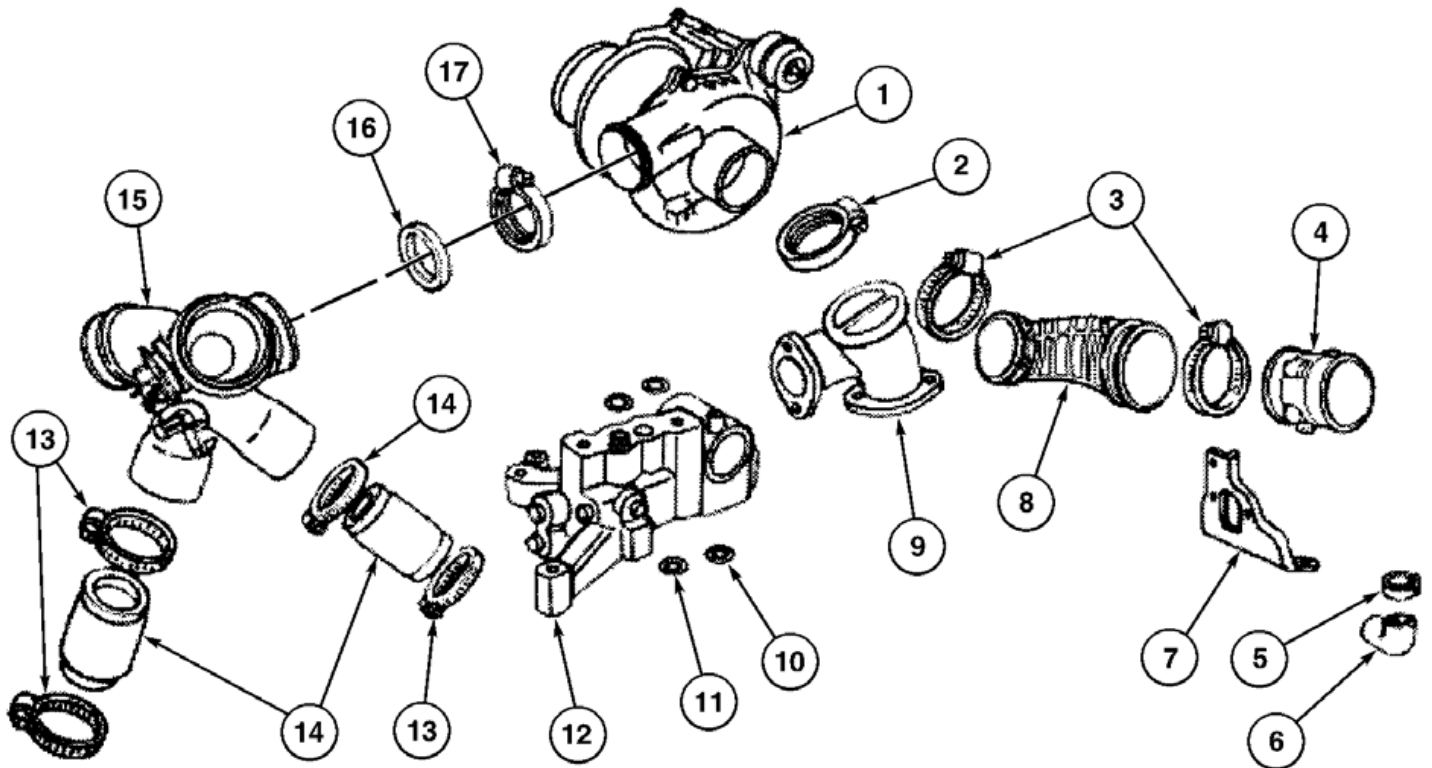

- | | |
|--------------------------------------|--------------------------------------------------|
| 1 Turbocharger | 10 Turbocharger Oil Supply "O" Ring (2 Required) |
| 2 Marmon Clamp | 11 Turbocharger Oil Drain "O" Ring (2 Required) |
| 3 Clamp | 12 Turbocharger Pedestal Assembly |
| 4 Air Inlet Duct | 13 Clamp |
| 5 Breather Hose Elbow Clamp | 14 Intake Manifold Hose (2 Required) |
| 6 Breather Hose Elbow | 15 Compressor Manifold |
| 7 Air Inlet Bracket | 16 Turbocharger Compressor Outlet Seal |
| 8 Air Inlet Hose | 17 Marmon Clamp |
| 9 Turbocharge Exhaust Inlet Manifold | |

REMOVAL

1. Remove the engine cover located near fuel filter/water separator. Disconnect the charge air cooler inlet and outlet pipes.

Label and disconnect the intake air heater element electrical leads, Intake Air Temperature (IAT) sensor electrical connector, Manifold Absolute Pressure (MAP) sensor electrical connector and the pressure hoses.

Loosen CAC to manifold clamps and disconnect CAC pipes.

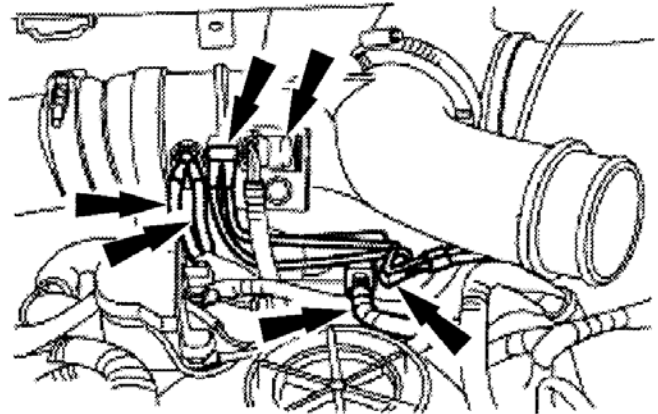

G00211533

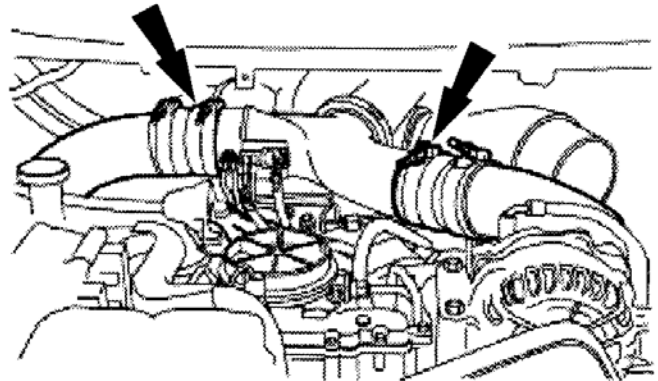

G00211532

2. Loosen the compressor manifold clamps and remove the compressor manifold. Remove and discard the compressor manifold "O" ring seal.

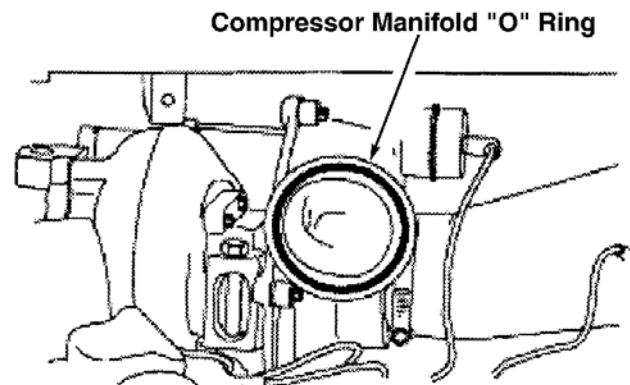

G00211534

BD Engine Brake Inc.

Plant Address: 33541 MacLure Rd. Abbotsford, BC, Canada V2S 7W2

U.S. Shipping Address: 88-446 Harrison St, Sumas, WA 98295 U.S. Mailing Address: P.O. Box 231, Sumas, WA 98295

Phone: 604-853-6096 | Fax: 604-853-8749 | Internet: www.bd-power.com

3. Loosen the exhaust outlet pipe Marmon clamp and disconnect the exhaust outlet pipe from turbocharger.

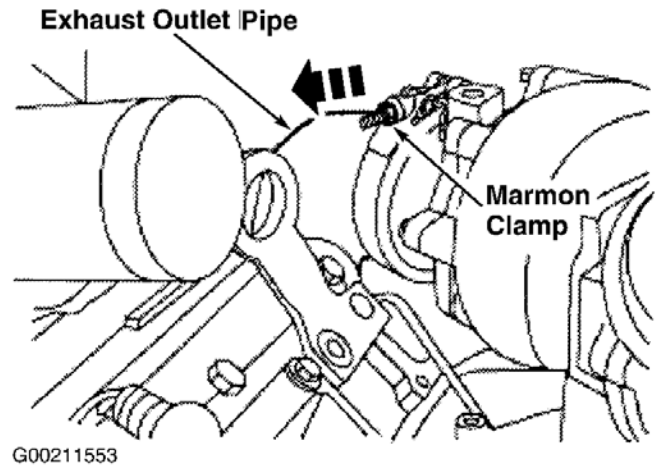

4. On vehicles with exhaust back pressure system, disconnect the exhaust back pressure valve by sliding the retaining clip away from the exhaust back pressure valve actuator lever. Detach the exhaust back pressure valve actuator rod.

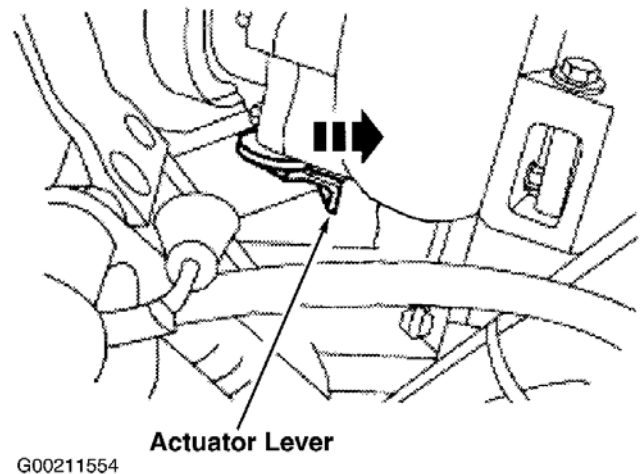

5. On all vehicles, label and disconnect the wastegate actuator vacuum and the pressure lines. Loosen the air inlet tube clamps and remove the air inlet tube.

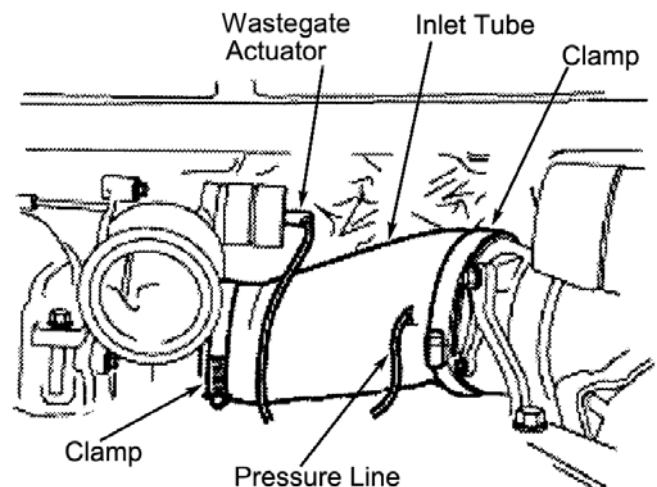

BD Engine Brake Inc.

Plant Address: 33541 MacLure Rd. Abbotsford, BC, Canada V2S 7W2

U.S. Shipping Address: 88-446 Harrison St, Sumas, WA 98295 U.S. Mailing Address: P.O. Box 231, Sumas, WA 98295

Phone: 604-853-6096 | Fax: 604-853-8749 | Internet: www.bd-power.com

6. Exhaust inlet Marmon clamp is located behind turbocharger. Loosen the Marmon clamp. Remove the turbocharger retaining bolts and remove the turbocharger. Remove and discard the "O" ring seals.

NOTE: The exhaust inlet Marmon clamp cannot be removed with the turbocharger installed.

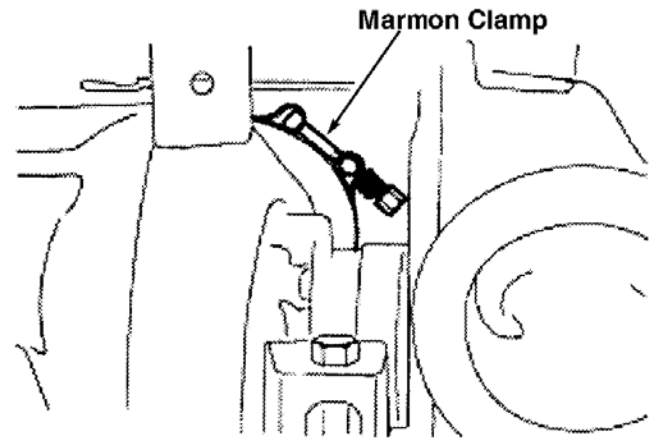

G00211556

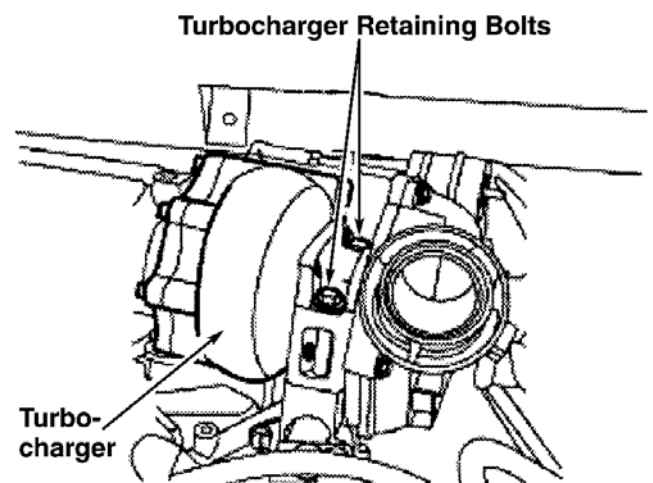

G00211557

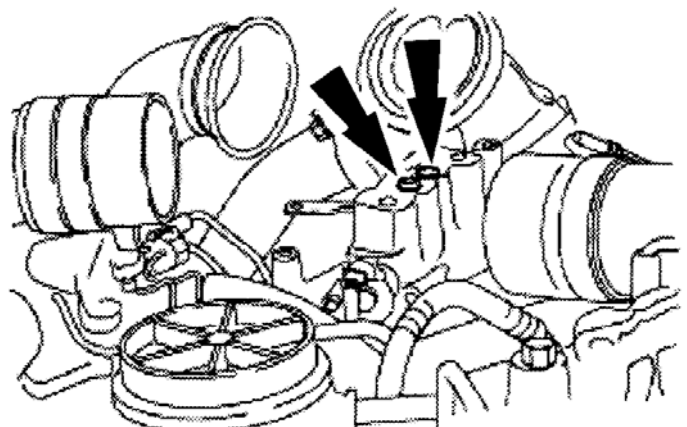

G00211558

BD Engine Brake Inc.

Plant Address: 33541 MacLure Rd. Abbotsford, BC, Canada V2S 7W2

U.S. Shipping Address: 88-446 Harrison St, Sumas, WA 98295 U.S. Mailing Address: P.O. Box 231, Sumas, WA 98295

Phone: 604-853-6096 | Fax: 604-853-8749 | Internet: www.bd-power.com

7. Disconnect the exhaust back pressure solenoid electrical connector. Remove the 4 pedestal mounting bolts and remove the turbocharger pedestal. Remove and discard the 2 turbocharger pedestal to engine "O" rings.

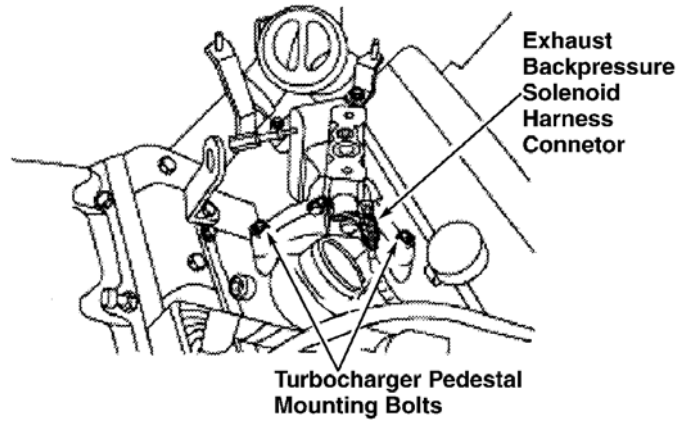

BD Engine Brake Inc.

Plant Address: 33541 MacLure Rd. Abbotsford, BC, Canada V2S 7W2

U.S. Shipping Address: 88-446 Harrison St, Sumas, WA 98295 U.S. Mailing Address: P.O. Box 231, Sumas, WA 98295

Phone: 604-853-6096 | Fax: 604-853-8749 | Internet: www.bd-power.com

INSTALLATION

Tighten fasteners using the following specifications.

Turbocharger Exhaust inlet pipe to exhaust manifold bolts	21 ft/lbs (28 N.m)
Turbocharger mounting bolts	18 ft/lbs (24 N.m)
Turbocharger pedestal assembly mounting bolts	18 ft/lbs (24 N.m)

INSTALLATION NOTES - To install, reverse the removal procedure.

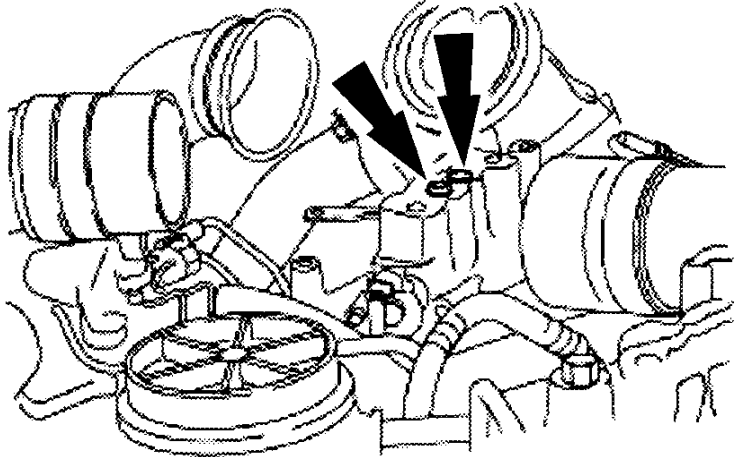
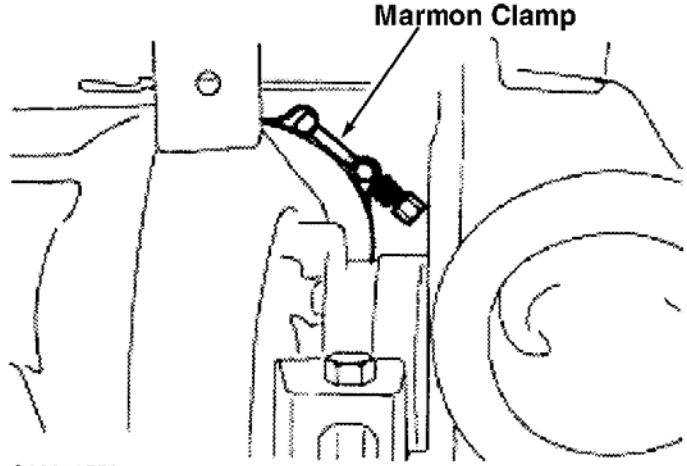
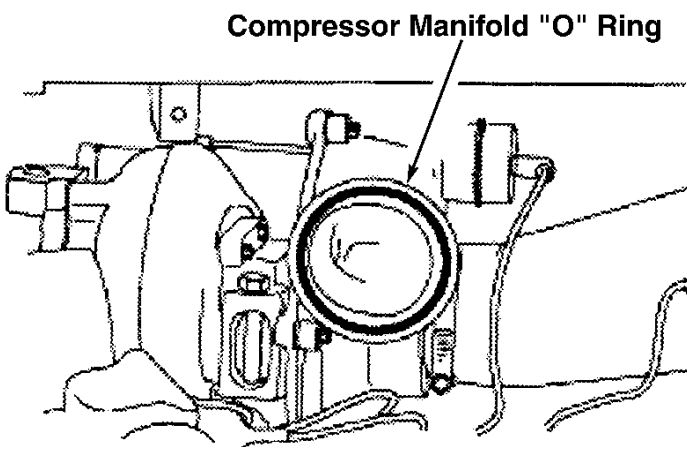
<ul style="list-style-type: none"> • Install New "O" rings. Reference step 6 of the removal process for the placement of the seals. 	
<ul style="list-style-type: none"> • The exhaust inlet Marmon clamp must be positioned on the exhaust inlet pipe before installing the turbocharger. 	
<ul style="list-style-type: none"> • Install the compressor manifold seal oring seal. (234-ORING) Reference step 2 of the removal process for placement. 	

BD Engine Brake Inc.

Plant Address: 33541 MacLure Rd. Abbotsford, BC, Canada V2S 7W2

U.S. Shipping Address: 88-446 Harrison St, Sumas, WA 98295 U.S. Mailing Address: P.O. Box 231, Sumas, WA 98295

Phone: 604-853-6096 | Fax: 604-853-8749 | Internet: www.bd-power.com

Note orientation upon installation of the turbo hose.

