

# ***BD Twin Turbo Kit***

**1994 - 1998 Dodge 12v 6BTA**

**Part# 1045310**

PLEASE READ ALL INSTRUCTIONS BEFORE INSTALLATION.

*\* Picture as shown features recommended optional 3-piece HD Exhaust Manifold (BD P/N# 1045980)*

**UNLESS AN EO# IS LISTED, THIS PRODUCT IS LEGAL IN CALIFORNIA FOR RACING VEHICLES ONLY, WHICH MAY NEVER BE USED UPON A HIGHWAY.**

**BD ENGINE BRAKE, INC.**

Plant Address: A10-33733 King Rd, Abbotsford, BC, Canada V2S 7M9  
US Shipping Address: 88-446 Harrison St, Sumas, WA 98295 US Mailing Address: PO Box 231, Sumas, WA 98295  
Phone: 604-853-6096 Fax: 604-853-8749 Internet: [www.bd-power.com](http://www.bd-power.com)

**KIT CONTENTS :**

Please check to make sure that you have all the parts listed in this kit before you start un-assembling your truck.



| <b>DODGE 12V TWIN TURBO KIT (BD# 1045310)</b> |   |   |                                  |
|---|---|---|----------------------------------|
| <b>1405230</b>                                | <b>1405217</b>                            | <b>1453109</b>                          | <b>1452985</b>                   |
|   |   |   |                                  |
| <i>Primary Turbo (Non-wastegated)</i>         | <i>Secondary Turbo (Wastegated)</i>       | <i>Primary Turbo Oil Drain</i>          | <i>Secondary Turbo Oil Drain</i> |
| <b>Qty: 1</b>                                 | <b>Qty: 1</b>                             | <b>Qty: 1</b>                           | <b>Qty: 1</b>                    |
| <b>1453120</b>                                | <b>1453405P</b>                           | <b>1453600</b>                          |                                  |
|   |   |   |                                  |
| <i>Primary Turbo Support Bracket</i>          | <i>Primary Air Outlet Pipe</i>            | <i>Primary Exhaust Outlet Pipe</i>      |                                  |
| <b>Qty: 1</b>                                 | <b>Qty: 1</b>                             | <b>Qty: 1</b>                           |                                  |
| <b>1453602</b>                                | <b>1100740</b>                            | <b>1453700P</b>                         | <b>1453305P</b>                  |
|   |   |   |                                  |
| <i>Down Pipe V-Band Clamp</i>                 | <i>4" Stainless Steel Down Pipe Clamp</i> | <i>Air Filter to Primary Turbo Pipe</i> | <i>Secondary Air Inlet Pipe</i>  |
| <b>Qty: 1</b>                                 | <b>Qty: 1</b>                             | <b>Qty: 1</b>                           | <b>Qty: 1</b>                    |
| <b>1459122P</b>                               | <b>1453502</b>                            | <b>1045981</b>                          | <b>1453110 &amp; 1453116</b>     |
|   |   |   |                                  |
| <i>Intercooler Extension Pipe</i>             | <i>Primary to Secondary Exh Pipe</i>      | <i>Exhaust Manifold Gasket Set</i>      | <i>Primary Oil Drain</i>         |
| <b>Qty: 1</b>                                 | <b>Qty: 1</b>                             | <b>Qty: 1</b>                           | <b>Qty: 1</b>                    |





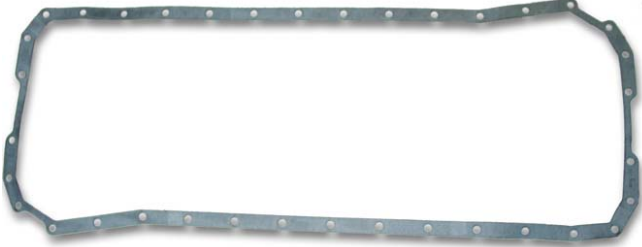

**BD ENGINE BRAKE, INC.**

Plant Address: A10-33733 King Rd, Abbotsford, BC, Canada V2S 7M9

US Shipping Address: 88-446 Harrison St, Sumas, WA 98295 US Mailing Address: PO Box 231, Sumas, WA 98295

Phone: 604-853-6096 Fax: 604-853-8749 Internet: www.bd-power.com

|   |   |
|---|---|
| <b>3959052</b>  | <b>3938157</b>  |
|  |  |
| <b>Oil Pan Gasket</b>   | <b>Gasket</b>   |
| <b>Qty: 1</b>   | <b>Qty: 1</b>   |

| <b>PRIMARY TURBO HARDWARE KIT (BD# 1453192)</b>                                   |   |   |   |  |   |
|---|---|---|---|--|---|
| 1453111   | 1120031   | 1453121   | 1453122   | 1453113  | 1453115   |
|  |  |  |  |  |  |
| <b>Upper Oil Drain Bolt<br/>(3/8NC x1.25)</b>                                     | <b>Oil Drain Washer<br/>(3/8)</b>   | <b>Pri. Support Bolt<br/>(M12x1.75x25)</b>  | <b>Pri. Support Washer<br/>(M12)</b>  | <b>Oil Drain Hose Clamps</b>   | <b>Oil Feed Adapter<br/>1/8NPT x -6JICM</b>   |
| <b>Qty: 2</b>   | <b>Qty: 2</b>   | <b>Qty: 1</b>   | <b>Qty: 1</b>   | <b>Qty: 2</b>  | <b>Qty: 1</b>   |

| 1453503   | 1453504   | 1462430   | 1462440  | 1405926 (0406)  |
|---|---|---|--|---|
|  |  |  |  |  |
| <b>Heat Shield</b>  | <b>Zip Tie</b>  | <b>Stud<br/>(M10x1.5)</b>   | <b>Nut<br/>(M10x1.5)</b>   | <b>Secondary Turbo Cast Pipe Clamp</b>  |
| <b>Qty: 1</b>   | <b>Qty: 3</b>   | <b>Qty: 4</b>   | <b>Qty: 4</b>  | <b>Qty: 1</b>   |





| <b>SECONDARY TURBO HARDWARE KIT (BD# 1453292)</b>                                   |   |   |   |  |   |   |
|---|---|---|---|--|---|---|
| 1453980   | 1453982   | 1453983   | 1604102   | 1604104  | 1453113   | 1453316   |
|  |  |  |  |  |  |  |
| <b>Turbo Mnt. Bolt<br/>(3/8NFx1.25)</b>   | <b>Turbo Mnt. Nut<br/>(3/8NF Gold)</b>  | <b>Turbo Mnt. Washer<br/>(3/8 Gold)</b>   | <b>Lock Washer<br/>(8mm)</b>  | <b>Bolt<br/>(M8x1x25)</b>  | <b>Oil Drain Clamps</b>   | <b>Spacer Plate</b>   |
| <b>Qty: 2</b>   | <b>Qty: 2</b>   | <b>Qty: 4</b>   | <b>Qty: 2</b>   | <b>Qty: 2</b>  | <b>Qty: 2</b>   | <b>Qty: 1</b>   |

**BD ENGINE BRAKE, INC.**





Plant Address: A10-33733 King Rd, Abbotsford, BC, Canada V2S 7M9  
 US Shipping Address: 88-446 Harrison St, Sumas, WA 98295 US Mailing Address: PO Box 231, Sumas, WA 98295  
 Phone: 604-853-6096 Fax: 604-853-8749 Internet: www.bd-power.com





| <b>TURBO HEAT SHIELD KIT (BD# 1459110)</b>  |   |   |
|---|---|---|
| 1459111   | 1459112   | 1459113   |
|  |  |  |
| <i>Heat Wrap</i>  | <i>Inner Wrap</i>   | <i>S/S Wire</i>   |
| Qty: 1  | Qty: 1  | Qty: 48"  |

**HOSE & CLAMP KIT (BD# 1453492)**

| 1405222   | 1405221   | 1405213   | 1405211   | 1453701   |
|---|---|---|---|---|
|  |  |  |  |  |
| <i>4"i.d. Hose<br/>(4" each)</i>  | <i>3"i.d. Hose<br/>(4"/each)</i>  | <i>Clamp (4.11")</i>  | <i>Clamp (3.25")</i>  | <i>Clamp (4")</i>   |
| Qty: 2  | Qty: 2  | Qty: 2  | Qty: 4  | Qty: 2  |

| 1453130-B  | 1453112  | 1453161  | 1453162   |
|--|--|--|---|
|  |  |  |  |
| <i>Primary Oil Feed Hose</i>   | <i>7/8" Upper Oil Drain<br/>Hose (4")</i>  | <i>Primary Oil Inlet<br/>Adapter<br/>(-6JICMx-6JICF 90°)</i>                         | <i>Primary Oil Inlet<br/>Fitting (1/4MPTx-<br/>6JICM)</i>                             |
| Qty: 1   | Qty: 2   | Qty: 1   |   |

| <b>AIR BOX KIT (BD# 1453892)</b>  |   |  |   |   |
|---|---|--|---|---|
| 1453805T  | 2924  | 1453803  | 1453802   | 1453801   |
|  |  |  |  |  |
| <i>Powder Coated Air Box</i>  | <i>Air Box Filter</i>   | <i>Nut<br/>(1/4)</i>   | <i>Washer<br/>(1/4)</i>   | <i>Spacer</i>   |
| Qty: 1  | Qty: 1  | Qty: 3   | Qty: 3  | Qty: 1  |

If you believe you are missing parts in your kit, please call (800) 887-5030 to arrange for replacements.

**BD ENGINE BRAKE, INC.**

Plant Address: A10-33733 King Rd, Abbotsford, BC, Canada V2S 7M9  
 US Shipping Address: 88-446 Harrison St, Sumas, WA 98295 US Mailing Address: PO Box 231, Sumas, WA 98295  
 Phone: 604-853-6096 Fax: 604-853-8749 Internet: www.bd-power.com

***Pre-Installation***

For the purpose of the instruction manual, the term “primary turbo” refers to the larger non-wastegated turbo and the term “secondary turbo” refers to the smaller wastegated turbo.

Installation should occur on a cold vehicle, as turbo and exhaust components become very hot with use.

The BD twin turbo system is recommended for trucks with 375-525 RWHP. We do have other kits available for higher horsepower. Please call us to discuss your options.

Also note that a stock transmission will not handle this power and torque, transmission modifications are a must.

***Options***

| <i>Description</i>                 | <i>Part #</i>   |
|------------------------------------|-----------------|
| BD ‘X’ Torque Converter            | <b>1070215X</b> |
| BD Transmission                    | <b>CALL</b>     |
| BD High Flow Injectors             | <b>CALL</b>     |
| BD X-Monitor                       | <b>1085200</b>  |
| Head Studs                         | <b>CALL</b>     |
| BD High Pressure Intercooler Boots | <b>1045210</b>  |

**WHEN EITHER UPGRADING OR INSTALLING THE TWIN TURBO KIT THE WASTEGATE WILL NEED TO BE ADJUSTED. THIS WASTEGATE IS ADJUSTABLE BY TURNING THE ACTUATOR ROD. SEE THE SECTION AT THE END IF THE INSTRUCTION MANUAL FOR COMPLETE DETAILS.**

**YOU SHOULD RUN AS MUCH BOOST AS POSSIBLE TO KEEP YOUR EGTS IN CONTROL. IF THIS MEANS RUNNING 65PSI OF BOOST PRESSURE, THAT IS FINE, JUST KEEP YOUR EGTS AS LOW AS POSSIBLE. THE KIT WILL PERFORM BEST WHEN THE WASTEGATE IS CLOSED AS LONG AS POSSIBLE.**

**USE YOUR FUELING (ELECTRONIC OR MECHANICAL) TO CONTROL YOUR BOOST LEVEL NOT THE WASTEGATE. THIS WILL RESULT IN LOWER EGTS, BETTER FUEL ECONOMY AND A QUICKER SPOOLING TURBOCHARGER.**

## Battery Disconnect

Disconnect the negative terminals on both of the vehicle's batteries, and then disconnect the positive terminals.

## Installation

1. Record radio settings and disconnect both battery terminals on both batteries.

2. Lay a protective cover over the passenger side fender to eliminate any scratches.

3. Remove the air box assembly and intake tube from inlet of turbocharger.

4. Remove the two 13mm bolts connecting the exhaust down pipe to the turbo flange.

5. Remove the cast aluminum elbow attached to the turbo compressor housing outlet. You will need to loosen the 'V' band clamp and the band clamp with a 7/16" deep socket. Be sure not to lose the o-ring from the aluminum elbow, as you will re-use the aluminum elbow assembly later.

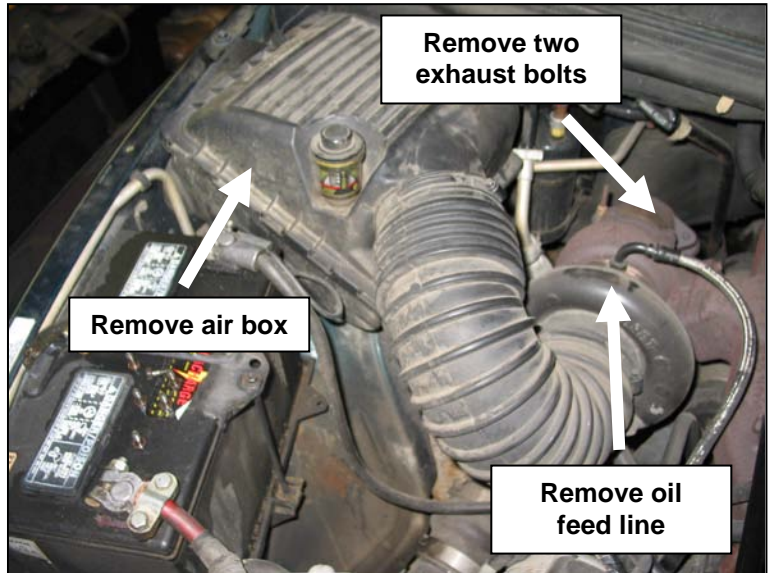

6. Remove the black steel intercooler tube. You will need to loosen the band clamp on the intercooler using a 7/16" deep socket.

7. Remove the turbo oil feed line (top of turbo) from the turbo by holding the 19mm turbo fitting with a wrench and remove the 13/16" line fitting – place line to the side. As well you may now remove the 19mm oil feed fitting.



8. Unbolt the turbo oil drain tube (bottom of turbo) by removing the two 10mm bolts.

9. Remove the lower hose clamp on the turbo oil drain boot and remove the oil drain tube and hose as an assembly as you will need the re-use the hose later.

### **BD ENGINE BRAKE, INC.**

Plant Address: A10-33733 King Rd, Abbotsford, BC, Canada V2S 7M9

US Shipping Address: 88-446 Harrison St, Sumas, WA 98295 US Mailing Address: PO Box 231, Sumas, WA 98295

Phone: 604-853-6096 Fax: 604-853-8749 Internet: [www.bd-power.com](http://www.bd-power.com)

10. Remove the four nuts holding the turbo to the exhaust manifold with a 15mm wrench—remove the stock turbo and set it aside.

11. Remove the stock down pipe and intermediate pipe from the exhaust system.

12. Remove the nut holding the heater core line to the exhaust manifold stud using a 15mm socket.

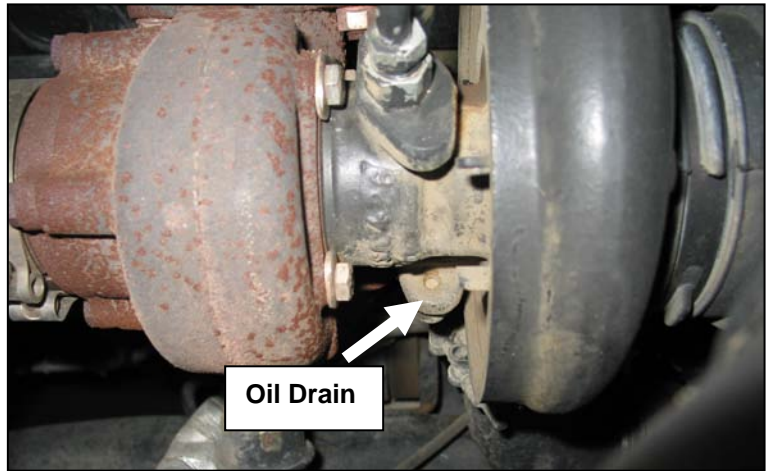

13. Remove the exhaust manifold bolts with a 13mm socket. Remove the spacers and finally the manifold at this time. Be sure not to lose the spacers.

14. Discard all exhaust manifold gaskets and clean then engine block and exhaust manifold mating surface.

15. Reinstall the exhaust manifold in an **inverted manner** so the turbo flange faces upward. Use the provided manifold gaskets and the factory bolts, spacers and retainers and torque to 32 ft lbs with a 13mm socket.

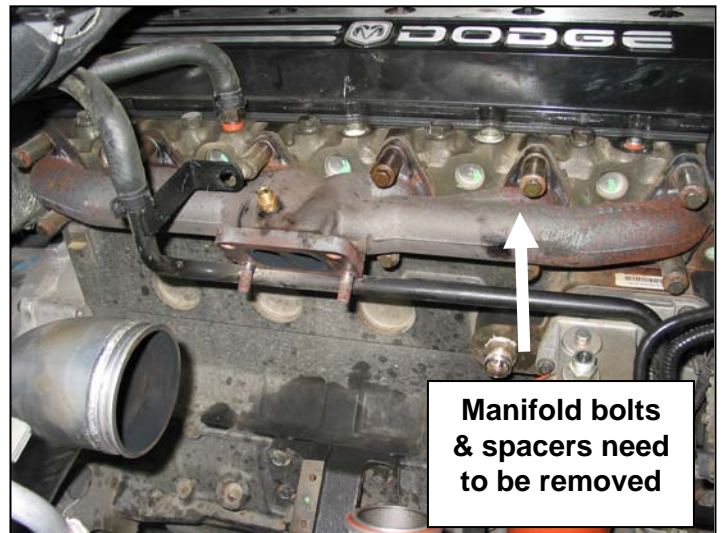

**Note:** If you have purchased a heavy-duty aftermarket manifold, you will need to install it in the same inverted manner. Please consult the manifold's instructions for complete installation.

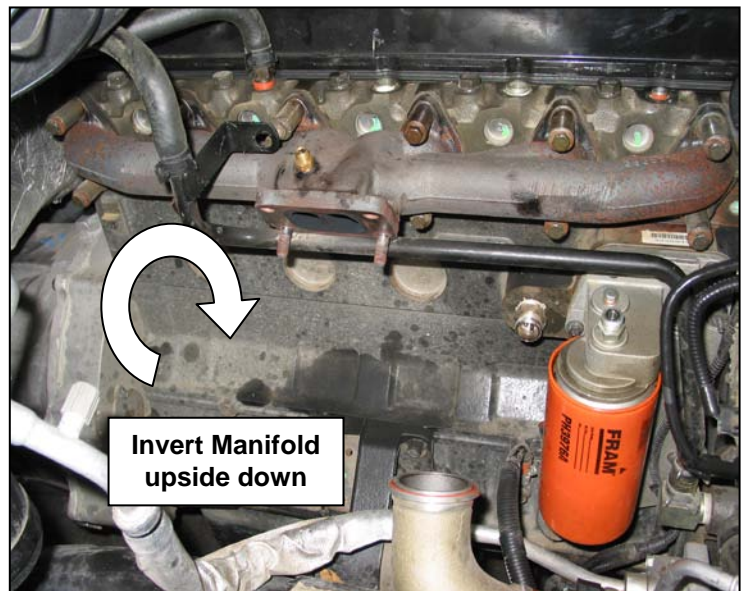

**BD ENGINE BRAKE, INC.**

Plant Address: A10-33733 King Rd, Abbotsford, BC, Canada V2S 7M9

US Shipping Address: 88-446 Harrison St, Sumas, WA 98295 US Mailing Address: PO Box 231, Sumas, WA 98295

Phone: 604-853-6096 Fax: 604-853-8749 Internet: www.bd-power.com

## ***Turbo Preparation & Installation***

*To alleviate any fit problems, all turbocharger support bolts, housing bolts and clamps must be loose. Once everything has fit together, then tighten all bolts.*

16. Remove the primary and secondary turbos from their boxes and remove any paper that may be in the inlets or outlets. It is critical that nothing is left inside of the turbos.

17. On both turbos, loosen the 4 bolts (1 turn only) that secure the exhaust turbine housing to the turbo CHRA with a 13mm wrench.

Then, loosen the 8 bolts that are securing the turbo compressor housing to the CHRA with a 13mm wrench. This will allow the two housings to rotate freely.

Be careful not to loosen the housings off too much as they will fall off and possibly damage the turbo wheels. The clamps should only be loose enough to clock the housings.

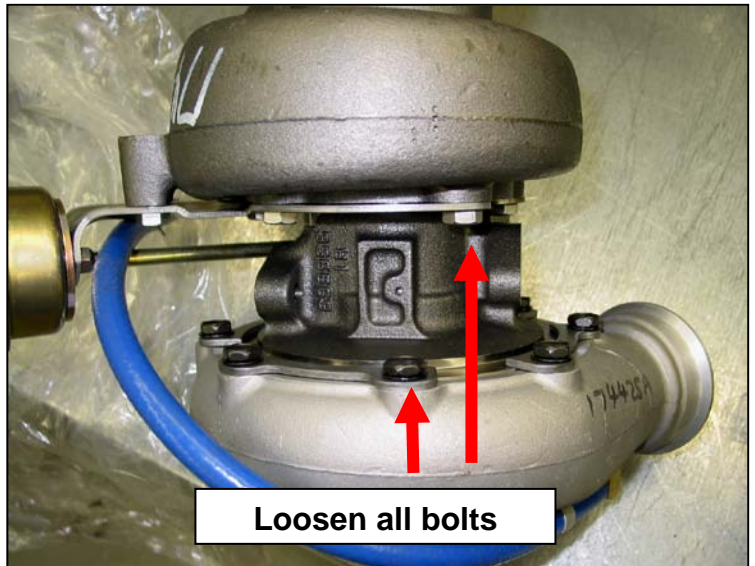

18. Thread the previously uninstalled OEM 19mm oil feed adapter into the *secondary turbo*. This is the adapter that was removed from the factory Holset turbo.
19. Install the long oil drain adapter onto the bottom of the *secondary turbo* with the supplied gasket and two 8mm X 25mm bolts and lock washers with a 13 mm socket.
20. On the larger primary turbo non wastegated (#1405230) remove the brass 90° flare fitting from the oil inlet. Locate the supplied 1/4MPT x -6JICM fitting (1453162), apply a very small amount of pipe sealant on the threads (DO NOT USE TEFLON TAPE). Now thread the fitting into the oil inlet, hand tighten then using a wrench turn the fitting ½ turn. DO NOT OVER TIGHTEN.
21. Slide the oil drain hose (#1453112) on to the tube. Then install the short oil drain adapter onto the bottom of the *primary turbo* with the supplied gasket and two 3/8" X 1-1/4" NC bolts and lock washers with a 9/16" wrench.

### **BD ENGINE BRAKE, INC.**

Plant Address: A10-33733 King Rd, Abbotsford, BC, Canada V2S 7M9

US Shipping Address: 88-446 Harrison St, Sumas, WA 98295 US Mailing Address: PO Box 231, Sumas, WA 98295

Phone: 604-853-6096 Fax: 604-853-8749 Internet: [www.bd-power.com](http://www.bd-power.com)

## \*\* Critical Step

22. Squirt fresh oil down the oil feed port of both turbo chargers while slowly rotating the compressor wheel.

23. Remove the 1/8 NPT plug using a 7/16" wrench from the top of the oil filter head and install the supplied JIC fitting (#1453162).

24. Mount the *secondary turbo* to the exhaust manifold.



## Installing with Stock Manifold

Mount the turbo to the manifold using the two factory studs and nuts, the supplied gasket, two 3/8" X 1-1/2 NF bolts, two 3/8" nuts and the four 3/8" flat washers. You will need to use two separate 9/16" wrenches.

## Installing with an Aftermarket Manifold

Remove the studs from your stock turbo and stock manifold for reinstallation into your aftermarket Heavy Duty Manifold. Install the turbo with the gaskets on either side of the spacer plate and reuse the factory mounting nuts. Note the stainless spacer will only need to be installed between the turbo and manifold if you are using an ATS aftermarket manifold.

25. Locate the cast flanged turbine adapter, and wrap the supplied heat shielding around the adapter. The heat shield has been formed in a specific pattern to completely wrap around the elbow. Use the 3 supplied stainless steel zip ties to secure the heat shield. One at the bottom, one at the middle and one at the top. Be sure that neither the heat shield or zip tie will interfere with the circular marmon flange when the band clamp is applied.



### **BD ENGINE BRAKE, INC.**

Plant Address: A10-33733 King Rd, Abbotsford, BC, Canada V2S  
 US Shipping Address: 88-446 Harrison St, Sumas, WA 98295 US Mailing Address: PO  
 Phone: 604-853-6096 Fax: 604-853-8749 Internet: [www.bd-power.com](http://www.bd-power.com)

26. You can now bolt the flanged turbine adapter to the primary turbo. Use the four M10x1.5 studs and serrated nuts to secure the adapter pipe to the turbo. At the same time mount the SS primary turbo support bracket to the assembly.

Note that the support bracket bolts on the bottom side of the turbine housing.

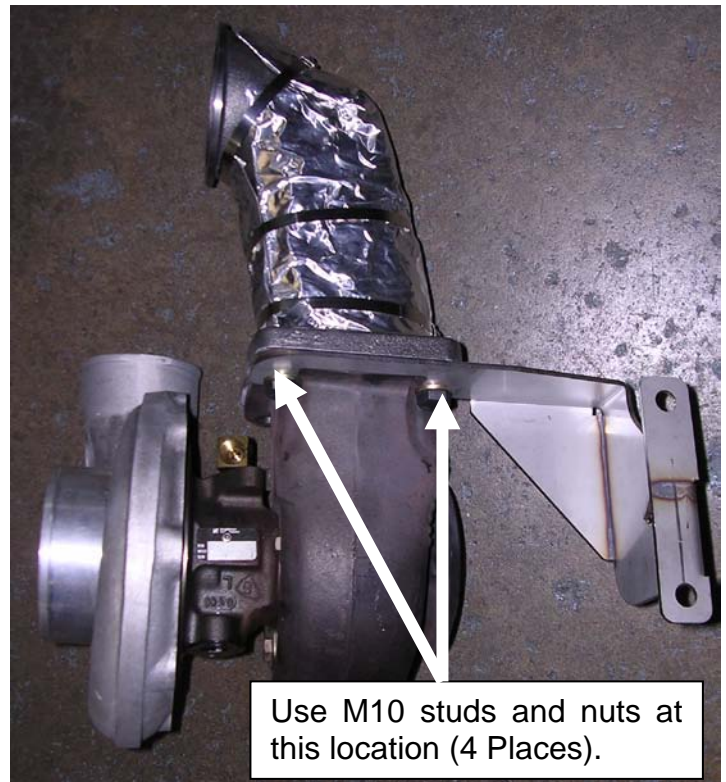

Use M10 studs and nuts at this location (4 Places).

27. Place the turbo and turbine adapter assembly onto the frame rail in a location close to the final install point. Be sure that it does not fall.
28. With the secondary turbo, bolt it loosely to the manifold and align the oil inlet straight up and the compressor outlet towards the bottom of the passenger battery.



29. Using the supplied v-band clamp (clamp will be labeled 995L2-0406) tighten the secondary exhaust housing to the primary turbo-turbine adapter assembly.

Make sure that heat shield or stainless zip tie does not interfere with the band clamp. Tighten the v-band clamp just enough so that you can still rotate the exhaust elbow.

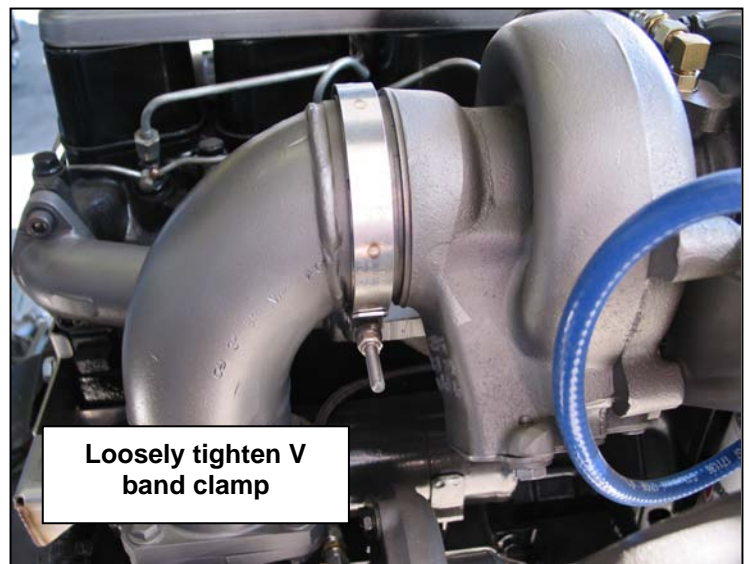

Loosely tighten V band clamp

**BD ENGINE BRAKE, INC.**

Plant Address: A10-33733 King Rd, Abbotsford, BC, Canada V2S 7M9

US Shipping Address: 88-446 Harrison St, Sumas, WA 98295 US Mailing Address: PO Box 231, Sumas, WA 98295

Phone: 604-853-6096 Fax: 604-853-8749 Internet: [www.bd-power.com](http://www.bd-power.com)

30. Install the *primary turbo* support bracket to the engine block with the supplied bolt (12mm x 1.75 x 25) and lock washer. Now tighten the bolts and V band clamp.

Now that the exhaust housings are in their proper locations, the turbo center sections can be twisted so that the turbo oil feeds are pointing straight up and drains are pointed at the block adapters. Tighten the exhaust housing bolts. Note that you may adjust the factory block oil drain adapter to help align the system.

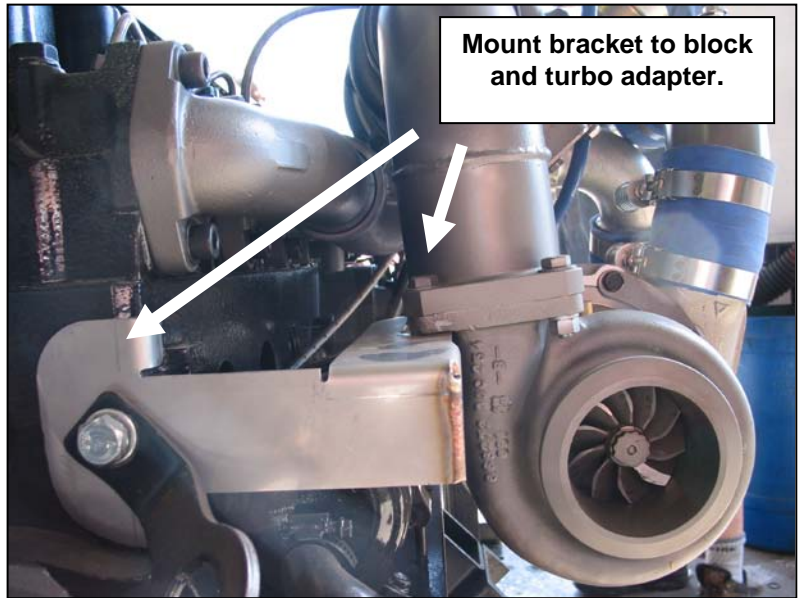

## *Primary Oil Drain Adapter Installation*

*Engines WITH a Frost Plug in the side of the block*

31. On the lower right side of engine, 6” from the rear of the engine block (just above the oil pan), there is a frost plug that caps an oil drain port that leads to the engine crankcase. This frost plug needs to be removed to serve as the oil drain for the *primary turbo*.

Great care needs to be taken when removing the frost plug so that it isn't forced into the oil pan.

The frost plug can be removed by coating a drill bit with grease (to catch any metal shavings) and by drilling a small hole in the center of the frost plug. Insert a sheet metal screw into the hole and pry the frost plug out with a pair of pliers.

Coat the lower portion of the supplied oil drain block adapter with Loctite or Anaerobic sealer and gently tap the spout into the block.



**BD ENGINE BRAKE, INC.**

## *Engines WITHOUT a Frost Plug in the side of the block*

32. Drain engine oil and leave out drain plug.
33. Clean off paint on the side of the pan between 3<sup>rd</sup> and 4<sup>th</sup> bolt from the rear of the engine as shown. This should be done before drilling the hole.

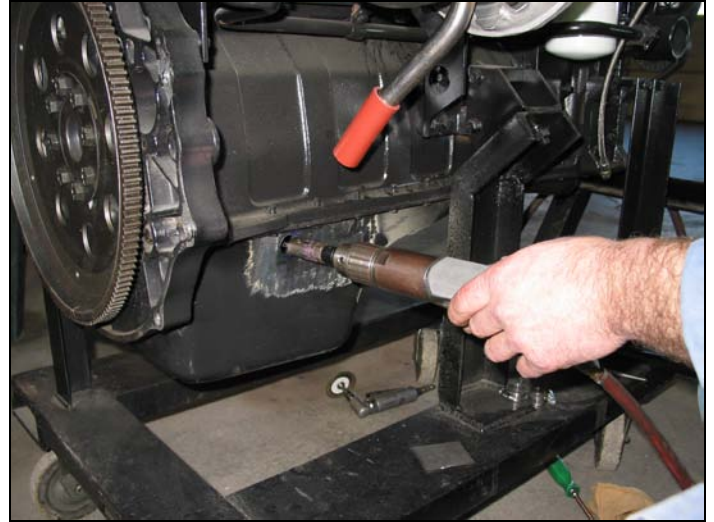

34. Center punch the pan 1 3/16" from inside of the top lip (or 1" from lip) between the 3<sup>rd</sup> and 4<sup>th</sup> bolts
35. Cut the marked oil drain hole using a 7/8" hole saw. You may want to use grease to ease the cleaning of the pan later on.
36. Clean the pan with brake clean and install supplied tube in the hole and with the silicone hose to the turbo drain tube you installed earlier, make sure to use the supplied clamps to secure it so it won't move while welding.
37. Clean the inside of the supplied oil drain tube and tack weld the tube into the pan, then remove the silicone hose and clamps.
38. Unbolt oil pan, pull down pan to gain access to the oil pickup tube, unbolt the pickup tube and drop it into the pan. To remove the oil pan you will have to unbolt engine mounts and raise the engine. As well unbolt the fan otherwise it will contact the shroud.
39. Once the pan is removed, clean pan thoroughly making sure to get all the debris out of the inside on the pan and complete the welding of the oil drain adapter.
40. Clean and paint any bare metal areas of the oil pan to reduce corrosion.

### **BD ENGINE BRAKE, INC.**

Plant Address: A10-33733 King Rd, Abbotsford, BC, Canada V2S 7M9

US Shipping Address: 88-446 Harrison St, Sumas, WA 98295 US Mailing Address: PO Box 231, Sumas, WA 98295

Phone: 604-853-6096 Fax: 604-853-8749 Internet: [www.bd-power.com](http://www.bd-power.com)

41. Place the clean oil pickup tube in the pan, while placing the new pan gasket on the outside of the pan. Now slide the pan into place. You will need to insert the pickup tube gasket in place before tighten the oil pickup tube to 18 ft lbs. This step is rather tight; you will have to slide your arm into place.

42. Once the oil pickup tube has been installed, you can tighten the pan bolts to 18 ft-lbs.

43. Reinstall/Retighten the engine mounts (75 ft lbs), as well install the oil drain plug with the gasket, and fill with 11.5 quarts of fresh oil.

44. Once the engine is secured, re-install the silicone oil drain hose to the primary oil drain tube with the supplied hose clamps.

45. Discard the factory oil drain hose and use the 4" supplied *secondary turbo* drain. This hose will attach to the factory drain adapter. Use the hose clamps to secure the connection. You will need to slide the oil drain flange adapter as far as possible away from the wastegate arm to prevent any contact. In some rare cases the wastegate arm may need to be bent.



46. Install the factory oil feed line into the 19mm oil feed adapter that will be installed in the *secondary turbo* (hold the fitting with a 19mm wrench and tighten the line with a 13/16" wrench), this line should run on the engine side of the turbo.

47. Install the 90° Oil feed adapter onto the 1/4NPT-JIC fitting (1453162) fitting you installed into the oil filter housing. Install the *primary turbo* oil feed line (1453130-B) from the JIC fitting you installed earlier in the filter housing to the JICM fitting on the *primary turbo*, the line should run between the turbo and engine.

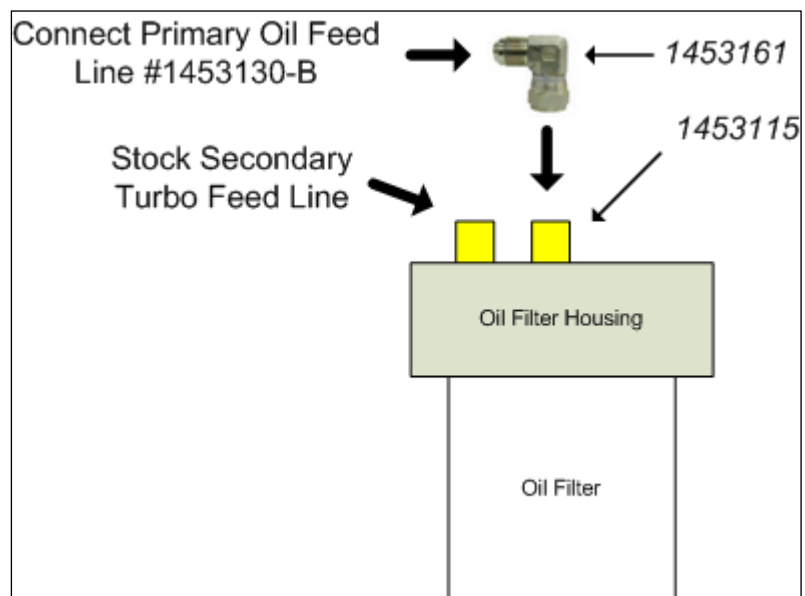

**BD ENGINE BRAKE, INC.**

Plant Address: A10-33733 King Rd, Abbotsford, BC, Canada V2S 7M9

US Shipping Address: 88-446 Harrison St, Sumas, WA 98295 US Mailing Address: PO Box 231, Sumas, WA 98295

Phone: 604-853-6096 Fax: 604-853-8749 Internet: [www.bd-power.com](http://www.bd-power.com)

**\*\* NOTE: All oil drains and feeds should be with +/-12° of vertical. \*\***

48. Remove the factory intercooler horn and boot from the factory intercooler pipe and place them on the new intercooler pipe provided.
49. Install the cast aluminum elbow and intercooler tube assembly to the compressor outlet of the *secondary turbo* and the lower intercooler boot. Secure with the factory v-band clamp and the two boot band clamps (use a 7/16" deep socket to tighten all clamps)

Do not forget to re-install the orange o-ring in the cast aluminum elbow before connecting the elbow to the compressor housing. You can now install the intercooler tube in place to the elbow and the intercooler.

50. The compressor housing of the *primary turbo* should still be loose and so adjustments can be made as required. Move the compressor housing around so that the fit is secure and the tubes will not hit anything when the engine torques over.

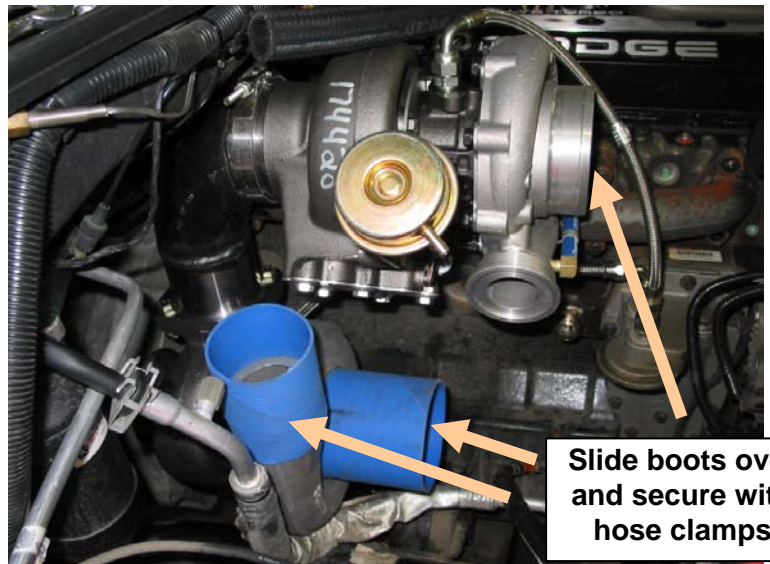

51. Install a 4 inch silicone boot on both the *primary turbo* and *secondary turbo* compressor housing inlets – also slide two Heavy Duty 4" band clamps on to each boot for easier installation later.

52. Install a 3" silicone boot on the compressor outlet of the *primary turbo* and slide two Heavy Duty 3" band clamps onto the boot.

53. Slide the 90-degree steel pipe into the compressor outlet boot on the *primary turbo* and point the pipe outlet towards the front of the vehicle.



54. Install a 3" silicone boot on the 3" 'U' 180° pipe and slide two Heavy Duty 3" band clamps onto the boot and

BD EN

Plant Address: A10-33733 Kin

US Shipping Address: 88-446 Harrison St, Sumas, WA 98290 — US Mailing Address: P.O. Box 207, Sumas, WA 98290

Phone: 604-853-6096 Fax: 604-853-8749 Internet: [www.bd-power.com](http://www.bd-power.com)

install it between the short 90° on the primary to the secondary turbo 4" inlet.

55. Once all intermediate pipes are lined up, the heavy-duty hose clamps can be tightened as well as the bolts on the *primary turbo* compressor housing.

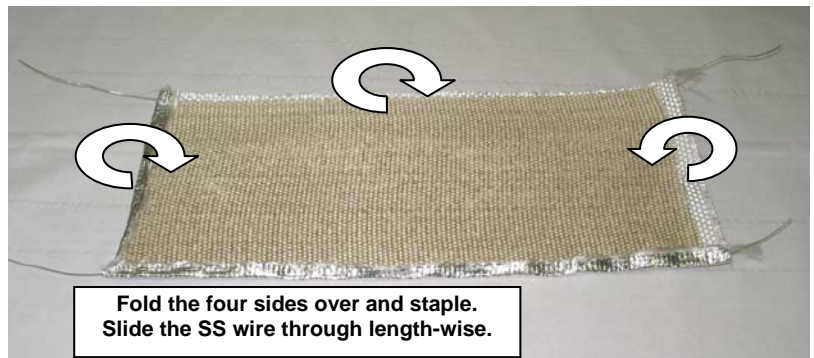

56. Loosely secure the new down pipe to the *primary turbo* using the supplied V-band clamp. Note that you will have to massage the firewall to allow enough clearance for the down pipe. Be sure to align all exhaust pipes, and then tighten the V band clamp on the back of the turbo. Once this is done you can finally clamp and weld the appropriate exhaust components.

57. In each kit there is a 17" section of silver exhaust wrap, along with a 16" tan section. You will need to stack these two pieces of wrap on top of each other, so that the silver wrap can be folded over the tan wrap on all four sides. Note that the silver side should be facing out, so that the tan wrap is fixed against the white side of the wrap. You will need to staple all four folds to secure them in place. Once secure, run the 40" stainless wire through the folds length-wise. You will need to do this on both sides.



58. Install the turbo heat shield as shown over the top of the secondary turbo exhaust housing and secure with the stainless wire. Completely wrap the blanket around the turbo housing, then tighten and tie off with the stainless steel wire.
59. Install the air box spacer on the stud at the front closest to the engine. This stud is lower than the other two.

**BD ENGINE BRAKE, INC.**

Plant Address: A10-33733 King Rd, Abbotsford, BC, Canada V2S 7M9

US Shipping Address: 88-446 Harrison St, Sumas, WA 98295 US Mailing Address: PO Box 231, Sumas, WA 98295

Phone: 604-853-6096 Fax: 604-853-8749 Internet: [www.bd-power.com](http://www.bd-power.com)

60. Insert the 4" intake tube into the air box and then into the silicone boot in the compressor-housing inlet of the *primary turbo*. Install air box onto the factory studs using the three supplied 1/4" NF nuts and the three supplied 1/4" flat washers.

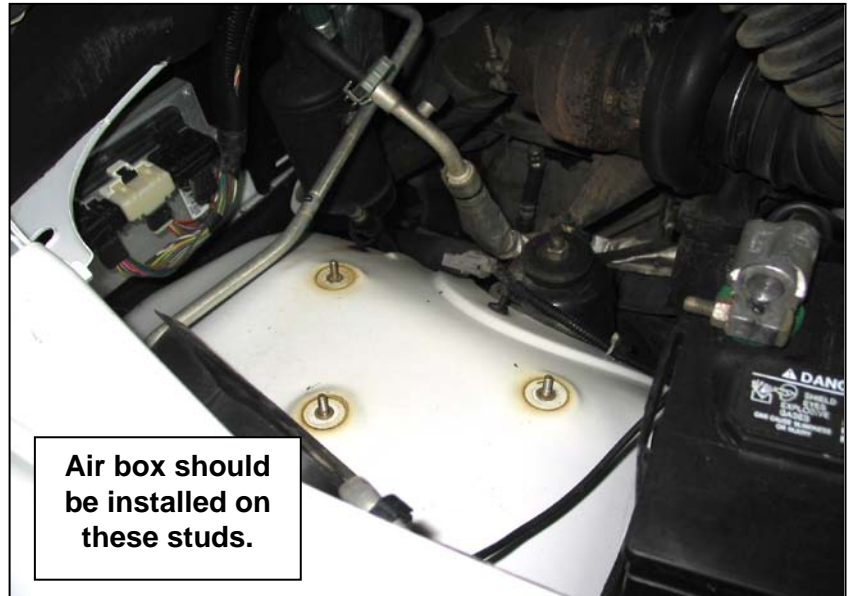

61. Using a 7/16 deep socket tighten the two band clamps on the silicone boots – ensure all pipes have good contact with the boots and at least 1/8" of boot sticks out past each clamp.

62. Install the supplied air filter by inserting it onto the pipe after it has passed through the air box and secure it with the supplied 4" hose clamp.

63. Re-connect the battery terminals and refill engine coolant. Double check all connections to make sure that they are all secure and free from any damage. You now may start the vehicle, once the vehicle has start and is up to temperature re-check for leaks and ensure that all the air is out of the coolant system.



**Note:** The exhaust housings of the turbos may smoke slightly when new, as manufacturing residue on housing must burn off.

## Twin Turbo Testing

It is highly recommended that allow the turbochargers to break in before any high power test runs. Slowly allow the turbo to come up to boost. Ideally the intake manifold pressure should not go above 52psi. You may have to adjust the waste gate with shims or a bleed orifice to ensure this boost level.

### **BD ENGINE BRAKE, INC.**

Plant Address: A10-33733 King Rd, Abbotsford, BC, Canada V2S 7M9

US Shipping Address: 88-446 Harrison St, Sumas, WA 98295 US Mailing Address: PO Box 231, Sumas, WA 98295

Phone: 604-853-6096 Fax: 604-853-8749 Internet: [www.bd-power.com](http://www.bd-power.com)

While driving listen for any odd noises such as a boost leak or perhaps piping rubbing against the vehicle. Once the vehicle has gone through a number of heat cycles it is highly suggested to retighten all clamps, bolts and nuts.

Periodically retighten all clamps and check for any oil or boost leaks.

**\*IMPORTANT\*** When idled for any length of time some oil may leak from the turbo. If the performance/boost is satisfactory and the wheel is not touching the housing (There will be some small movement), the excess oil is not a concern. Simply wipe with a clean cotton cloth and continue use.

## Wastegate Adjustments

### *YOU WILL NEED TO ADJUST THE WASTEGATE!!!*

The wastegate should be set to the maximum boost pressure possible. Close the wastegate and use the fueling box to control maximum boost. This combination will produce better fuel efficiency and cooler EGTs. If you still cannot control your boost you may need to look to a bigger set of twin turbos. Use the wastegate as a last resort.

It is better to have the wastegate closed as much as possible rather than open. If you are producing too high of boost pressure you will need to adjust your fueling to control the boost (either mechanically or electronically). Use the waste gate as a last resort.

**DO NOT SET THE WASTEGATE TO OPEN AT 40PSI AND WHILE RUNNING 55PSI MANIFOLD PRESSURE (EXAMPLE ONLY). THIS WILL OVERLOAD THE PRIMARY CHARGER AND HURT YOUR TOTAL ACHIEVABLE HORSEPOWER. ONCE AGAIN CLOSE THE WASTEGATE, THE TURBOCHARGERS WILL RUN MORE EFFICIENT.**

The wastegate is adjustable by turning the actuator rod. For more boost pressure you will need to tighten/shorten (clockwise) the waste gate rod for less boost pressure you can loosen the rod/lengthen (counter clockwise). The turning effect preloads the wastegate actuator spring. This adjustment is very finicky, be very careful, as you should not have to adjust the rod all that much. Make sure you are running enough boost for your horsepower requirements. If you have any questions or concerns call us.

#### **BD ENGINE BRAKE, INC.**

Plant Address: A10-33733 King Rd, Abbotsford, BC, Canada V2S 7M9

US Shipping Address: 88-446 Harrison St, Sumas, WA 98295 US Mailing Address: PO Box 231, Sumas, WA 98295

Phone: 604-853-6096 Fax: 604-853-8749 Internet: [www.bd-power.com](http://www.bd-power.com)

**BD WILL NOT BE RESPONSIBLE FOR ANY FAILURES OF THE VEHICLE'S  
HEAD GASKET.**

**BD ENGINE BRAKE, INC.**

Plant Address: A10-33733 King Rd, Abbotsford, BC, Canada V2S 7M9

US Shipping Address: 88-446 Harrison St, Sumas, WA 98295 US Mailing Address: PO Box 231, Sumas, WA 98295

Phone: 604-853-6096 Fax: 604-853-8749 Internet: [www.bd-power.com](http://www.bd-power.com)

To adjust the wastegate you will need to remove the rod end circlip first.

Then loosen the jam nut.

Apply air pressure to diaphragm. The actuator will then stroke, at this time lift up on the rod end and it will release from wastegate lever cylinder.

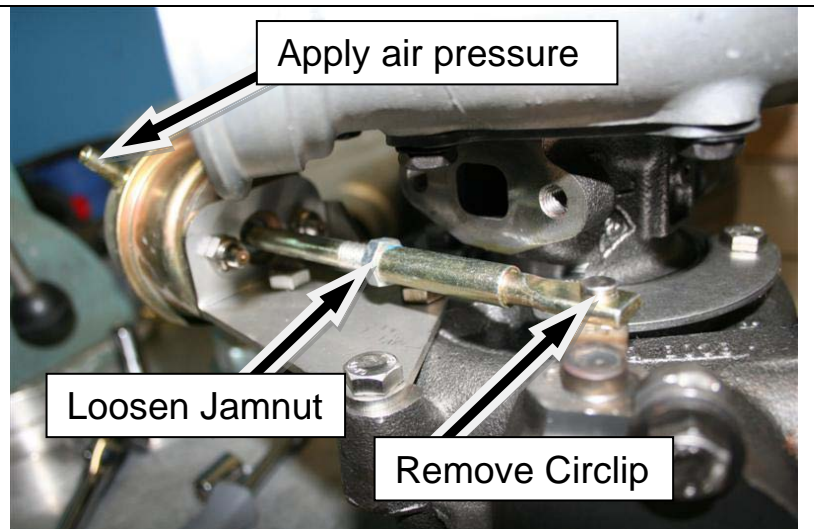

**Shorter Rod = Higher Opening Pressure = Higher Boost**

**Longer Rod = Lower Opening Pressure = Lower Boost**

Turn rod end to adjust wastegate opening pressure.

**Shorter Rod = Higher Opening Pressure**

**Longer Rod = Lower Opening Pressure**

We recommend the wastegate be almost closed off completely. Again use your fueling to control your boost level not your wastegate.

To re-install do the reverse of step 1.



**BD ENGINE BRAKE, INC.**

Plant Address: A10-33733 King Rd, Abbotsford, BC, Canada V2S 7M9

US Shipping Address: 88-446 Harrison St, Sumas, WA 98295 US Mailing Address: PO Box 231, Sumas, WA 98295

Phone: 604-853-6096 Fax: 604-853-8749 Internet: [www.bd-power.com](http://www.bd-power.com)