

# **BD POWER CAMPLATE KIT**

## **Installation Instructions**

**PLEASE READ ALL INSTRUCTIONS CAREFULLY BEFORE INSTALLATION.**

**NOTE:** Unless this product has been identified with a CARB # it is only legal in California for racing vehicles which may never be used upon a highway.

## Required Tools

- Fender Covers (To protect paint)
- 7/16" deep socket - 3/8" drive with 3" ratchet
- 10mm six point socket - 3/8" drive with extensions
- Tape or clean towels (To cover openings)
- 7mm and 1/4" six point sockets - 1/4" drive with 3" extensions
- 19mm socket - 3/8" or 1/2" drive
- Center punch 8-10" long
- Hammer to strike punch and hand impact tool
- Hand impact tool - 3/8" or 1/2" drive
- T15 & T20 TORX bits – 1/4" drive with 1/4" extension 6" long
- 1/4" to 3/8" and/or 1/2" adapter to hand impact tool
- 8mm, 6-point 1/4" drive socket
- Large standard screwdriver bit with 6" adapter for impact tool
- Large screwdriver or small pry bar
- Pliers
- 7/16" open-ended wrench
- 5/8" open-ended wrench
- Torque wrench (Capable of at least 30 ft. lbs.)
- RTV silicone sealant
- 8mm Allen wrench

### -- BD CAMPLATE APPLICATION RATINGS --

CUMMINS PICKUP TRUCK Torque Plate#	#12 – 1040195	#11 – 1040194	#10 – 1040197	#8 – 1040193	#6 – 1040192	#5 – 1040196
Stock Ratings	BHP/lbs-ft	BHP/lbs-ft	BHP/lbs-ft	BHP/lbs-ft	BHP/lbs-ft	BHP/lbs-ft
<b>1994-95 Automatic</b> 160hp 400 lbs. Ft --CPL#'s 1549, 1815, 1959, 1968	165/440	185/500	200/550	210/570	230/605	255/650 †
<b>1994-95 Manual</b> 175hp 420 lbs. Ft	190/500	210/550	220/570	230/605	250/635	270/675 †
<b>1996-98 Automatic</b> 180hp 420 lbs. Ft --CPL#'s CA, 1863 ** Stock injector orifice: .0095	190/500	210/550	220/570	230/605	250/635	270/675 †
<b>1996-98 Manual</b> 215hp 440 lbs. Ft CPL#'s 2023, 2175 Stock injector orifice: .0105	230/605	280/680	330/750†‡	NR	NR	NR

\*\* - The California 96-98 manual and automatic are both EGR engines – 180hp & 420 lbs-ft, which may not be to CPL# 1553

† - Stock automatic transmission or manual clutch (whichever applicable) will not handle this rating

‡ - Exhaust temperatures will run hot and may cause damage without airflow improvements

NR – Not Recommended

CUMMINS MOTORHOME Torque Plate#	#12 – 1040195	#11 – 1040194	#10 – 1040197	#8 – 1040193	#6 – 1040192	#5 – 1040196
Stock Ratings	BHP/lbs-ft	BHP/lbs-ft	BHP/lbs-ft	BHP/lbs-ft	BHP/lbs-ft	BHP/lbs-ft
<b>1992-97 Automatic</b> 5.9L 6BTA 239HP/605 lbs-ft	250/635	270/690	290/710	NR	NR	NR
<b>1991-96 Automatic</b> 5.9L 6BTA 190HP <b>1996-99 Automatic</b> 5.9L 6BTA 210HP	NR	220/570	230/605	240/645	260/660	NR
<b>1993-96 Automatic</b> 8.3L 6CTA 250hp	325/310	NR	NR	350/360	375/410	400/460

BD Engine Brake Inc.

Plant Address: 33541 MacLure Rd. Abbotsford, BC, Canada V2S 7W2

U.S. Shipping Address: 88-446 Harrison St, Sumas, WA 98295 U.S. Mailing Address: P.O. Box 231, Sumas, WA 98295

Phone: 604-853-6096 | Fax: 604-853-8749 | Internet: www.bd-power.com

## Installation

- 1) Park your vehicle in a suitable work location. Set your transmission in park (if automatic), manual transmissions into neutral and set your parking brake.
- 2) Take a note of your radio settings if you wish, as you will lose all stored memory in your stereo unit. Open your hood and disconnect **both** negative battery cables.

- 3) Clean the engine if necessary to keep debris and foreign objects from entering the engine.

- 4) Place fender covers or other protective covering to protect your paint and batteries.

- 5) Using a 7/16" deep socket, loosen the lower clamp on the upper intake connection hose and slide the lower clamp off of the hose and down the steel tube, out of the way. (See figure 1)

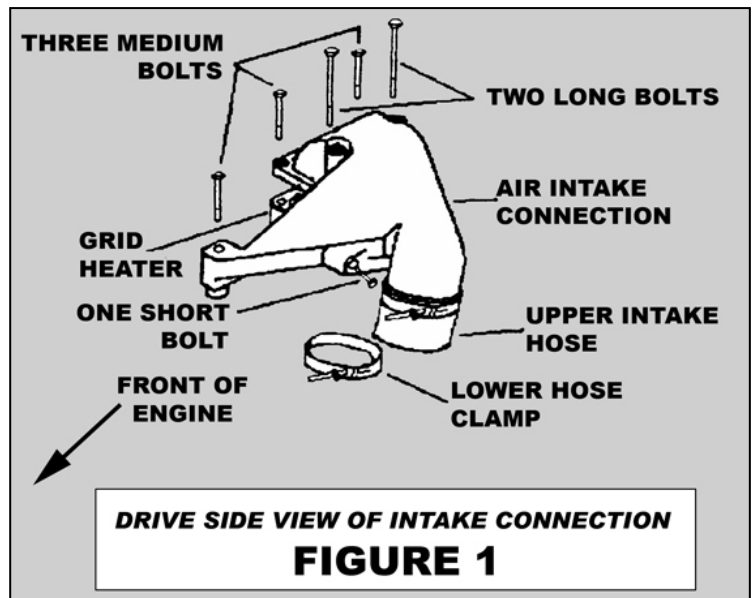

- 6) Remove the six bolts holding the air intake connection and dipstick tube in place using a 10mm six-point socket. **Take note of the bolt locations as they are different lengths and need to be re-installed in the proper location during re-assembly.**

- 7) Remove the intake manifold connection and hose as a unit, taking care not to damage the gasket. This gasket can normally be re-used, however if it is torn, replace it while lifting the air connection so that the gasket joint under the grid heater is not disturbed.

- 8) Cover the air tube and manifold openings with tape or towels to keep out any debris.

- 9) Determine where your vehicle obtains its wastegate pressure signal. Some vehicles pick up this signal at an elbow on the front of the turbo (see figure 2) while others get

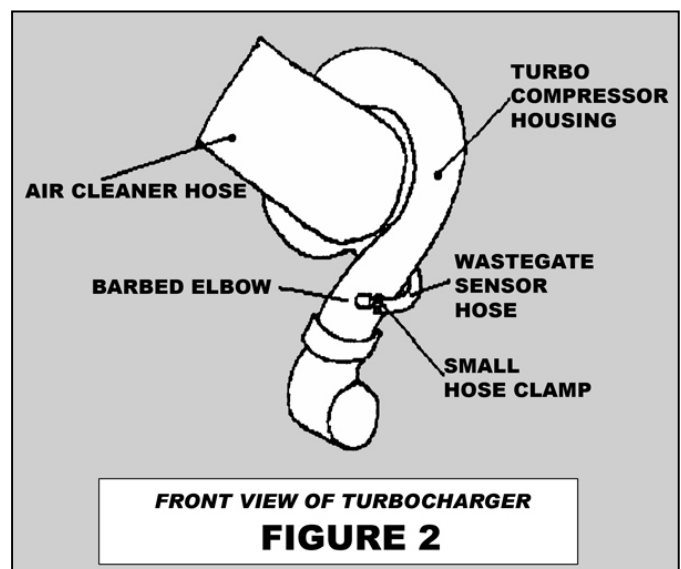

the signal at a tee connected to the rear of the injection pump (see figures 3 & 4). If your vehicle is the system shown in figure 2, skip to step 11. If your vehicle gets its wastegate signal from the tee at the rear injection pump, loosen the hose clamps on the AFC housing to the turbo wastegate tube air hose using a 7mm socket. Disconnect the hose from the barbed fitting on the top of the fuel pump Air Fuel Control (AFC) housing. Slide the hose as far down as possible onto the steel turbo wastegate tube.

- 10) Remove the barbed fitting from the AFC housing using a 7/16" deep barrel socket.

NOTE: Save this barbed fitting in case you want to convert your engine back to stock; This fitting is not used with the Camplate Kit.

- 11) Remove the injection pump fuel supply tube banjo bolt using a 19mm socket. A few ounces of fuel will drain out which could wash the sealing washers away. **Do not to lose the sealing washers, as they need to be re-used.** In the event that you lose or damage them, re-order Cummins part number 3918192. **NOTE:** The fuel supply tube is not removed; loosening it on the injection pump end allows access to get to the AFC housing screws. You can avoid removing the banjo bolt if you bend the fuel supply line slightly to make access to the break-off screw. (See figure 4) This option saves some time, eliminates breaking into the fuel line, and starts the engine quicker at the end of the install.

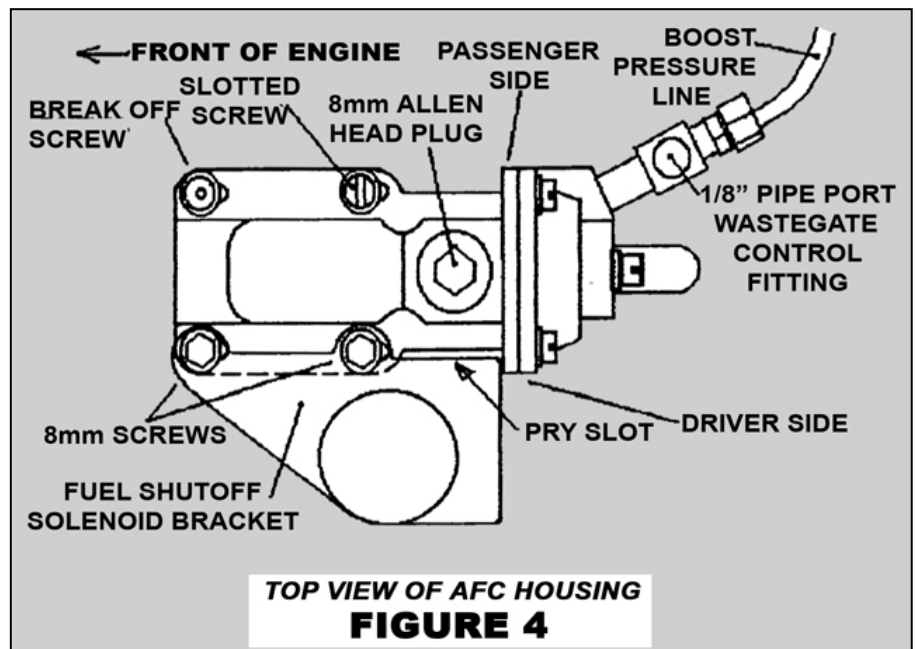
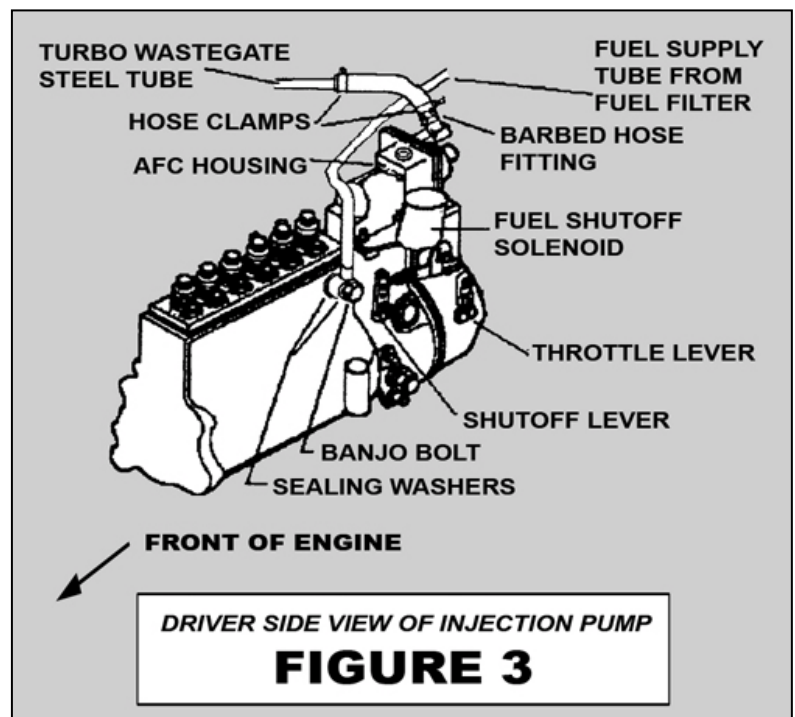

BD Engine Brake Inc.

Plant Address: 33541 MacLure Rd. Abbotsford, BC, Canada V2S 7W2

U.S. Shipping Address: 88-446 Harrison St, Sumas, WA 98295 U.S. Mailing Address: P.O. Box 231, Sumas, WA 98295

Phone: 604-853-6096 | Fax: 604-853-8749 | Internet: www.bd-power.com

- 12) Scribe the location of the AFC housing in relation to the pump. You will need to reattach the AFC housing in the same location.
- 13) Remove the front passenger side AFC housing break-off screw. This screw is a factory break-off screw with a rounded head and no screwdriver, Allen head or TORX slot (tamper proof). Use a hand impact tool with a 6" long ¼" extension and a T15 TORX bit to remove this screw. A center punch may be required to start a hole in the center of the screw. Set the hand impact tool in the removal position (counter-clockwise) and use light hammer taps on the impact tool to loosen the screw. Tap progressively harder allowing it to be re-installed later with the T15 TORX bit. In some cases, the hole in the top of the screw is too large for the T15 bit; In this case, use the T20 TORX bit. There is usually a lock washer and flat washer under each of these screws. As another option, you can use a sharp chisel to remove the break-off screw, chiseling in a counter-clockwise direction.
- 14) Use the hand impact tool and a 8mm socket to remove the two drivers side AFC screws.
- 15) Use the hand impact tool with a large standard screwdriver bit to remove the rear passenger side AFC screw.
- 16) Pry the fuel shutdown solenoid bracket away from the AFC housing using a larger screwdriver in the pry slot shown in FIGURE 4. This bracket only needs to move about 3/8" for clearance.

- 17) Lift the AFC housing and move it out of the way towards the rear of the engine. If your boost line is a plastic line, then it does not need to be disconnected. However, some engines have a metal boost line rather than a plastic line between the engine intake and the AFC housing. In this case, the boost line should be disconnected.

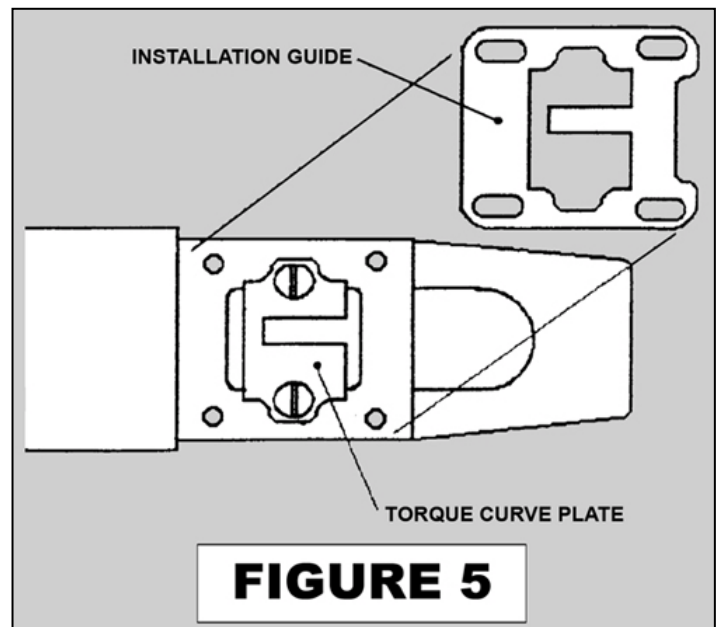

- 18) Place the black installation guide provided with the camplate kit over the torque curve plate (see Figure 5 & 6). This guide plate prevents objects from entering the open fuel pump and helps position the new torque curve plate.
- 19) Leave one of the torque plate screws tight while removing the other screw using the hand impact tool with a large screwdriver bit.

**20)** Move the removed screw and re-install it to one corner of the guide plate. Slide the installation guide as far towards the rear of the engine as possible so that there is zero clearance between the front edge of the torque curve plate flange and the installation guide (See *Figure 6*). Once zero clearance is achieved, hand-tighten the screw so that the guide does not move during the next four steps.

**21)** Remove the other torque plate screw and install it in another corner to help hold the guide in place.

**22)** Remove the stock curve plate using pliers or a magnet. Save the stock torque curve plate to permit converting the engine back to stock in the future.

**23)** Place the new torque curve plate in the same position that the stock plate was in, sliding it as far forward as possible so that there is nearly zero clearance between the front of the torque plate and the installation guide.

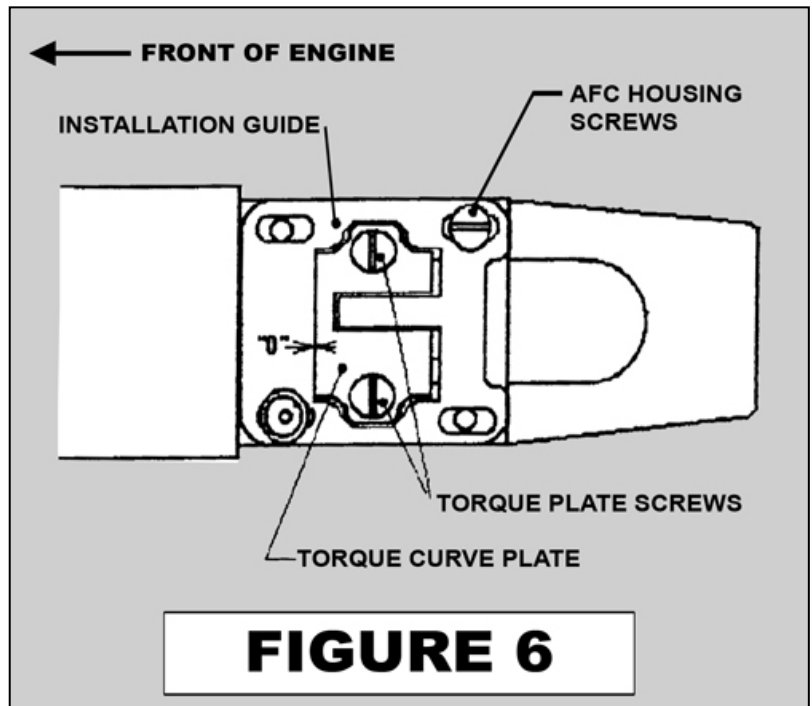

**24)** Install one of the two torque plate screws and hand tighten as tight as possible with a normal large screwdriver. Install the second screw. Using the hand impact tool and a large standard bit, tighten each screw another 1/8" to 1/4" turn.

**25)** Remove the installation guide and save it in case you want to convert the engine power back to stock.

**26)** Be sure that the AFC housing seal is in its groove (it may require a small amount of grease or silicone sealant to hold it in place), and then carefully re-install the AFC housing. Do NOT force the housing into the plate; rather ensure that the tang on the bottom of the housing fits into the slot in the torque curve plate. Wiring harnesses, hoses and the shut-off solenoid bracket may need to be moved to get the housing to drop into its proper location.

**27)** Move the shut-off solenoid bracket back to its original position so that the AFC housing mounting screws will pass through the proper holes in the bracket and housing.

- 28)** Install the AFC housing hold down screws loosely into their original locations (see *Figure 4*).
- 29)** Tighten three of the AFC mounting screws (not the break-off screw) as tight as possible with a normal screwdriver. Be sure to align the AFC with the scribe location you made earlier. Use the hand impact tool to turn each screw an additional 1/8" to 1/4" turn. It is suggested that you successfully complete the test drive before breaking off the head of the break-off screw; Only tighten it slightly to keep it from falling out during the test drive. You can re-use the original break-off screw by installing it with a TORX bit.
- 30)** Install the turbo boost control (the small brass elbow supplied) into the 1/8" pipe port for wastegate control (see *Figure 4*) in place of the barbed hose fitting removed in step 10. If your vehicle senses manifold pressure at the turbo (see *Figure 2*), remove the crimp type clamp with pliers, remove the stock elbow and install the boost control elbow from the camplate kit in its place. Lightly tighten this fitting using a 7/16" open-ended wrench, and then continue to tighten until the barbed end aligns with the turbo wastegate tube.
- 31)** Install the hose removed in step 9 onto the brass barb of the turbo boost control. The AFC housing to boost pressure line fitting may need to be loosened slightly using a 5/8" open-ended wrench for good alignment of the hose. Tighten the two hose clamps loosened in step 8 using a 7mm socket. If your vehicle uses the system shown in *Figure 2*, use the new hose clamp supplied in the camplate kit, re-attach the hose and tighten the clamp using a 1/4" socket. For vehicles with the metal boost line that was removed, re-install it now.
- 32)** Remove the duct tape or towels from the previously covered openings. Re-install the air connection gadget and the air intake connection, starting with the rubber hose on the air intake tube first, then rotating the connection into position.
- 33)** Clean any debris from the threads of the air connection bolts, then place a small amount of RTV sealer sparsely on the first 3/4" of the threads, re-install the bolts to their original position and tighten to 18 lbs. Ft. using a 10mm six point socket and suitable torque wrench.
- 34)** Re-install the lower air connection hose clamp and tighten it hand tight. Do NOT strip the threads on the clamp bolt. Check the other seven air circuit clamps, ensuring the four hoses and eight clamps are not leaking air.
- 35)** Remove fender and battery cover, lights, tools, etc., and re-connect the battery cables.

**36)** Start the engine and check for any leaks. Since there was an amount of fuel drained from the injection pump fuel supply tube, it is normal to take several seconds of cranking before the engine will start. Don't panic, this is normal. Depress the throttle to about half throttle position and crank the engine no more than 30 seconds. Let the starter motor cool for 2 minutes before attempting to crank for another 30 seconds. The engine will normally start during the first 10 seconds of cranking. If after four 30-second attempts the engine has not started, check to make sure the fuel shutoff solenoid and shutoff level are moving when the key is turned from off to start. When the engine starts, release the throttle back to the idle position and check under the hood for leaks.

**37)** Test-drive the vehicle - It should now have much more power and quicker acceleration than before. Observe the acceleration rate and smoke level. If the vehicle is still slow to accelerate or has too much smoke, adjust the AFC setting by removing the large plug on top of the AFC housing (see Figure 7) using an 8mm Allen wrench. Take care not to lose

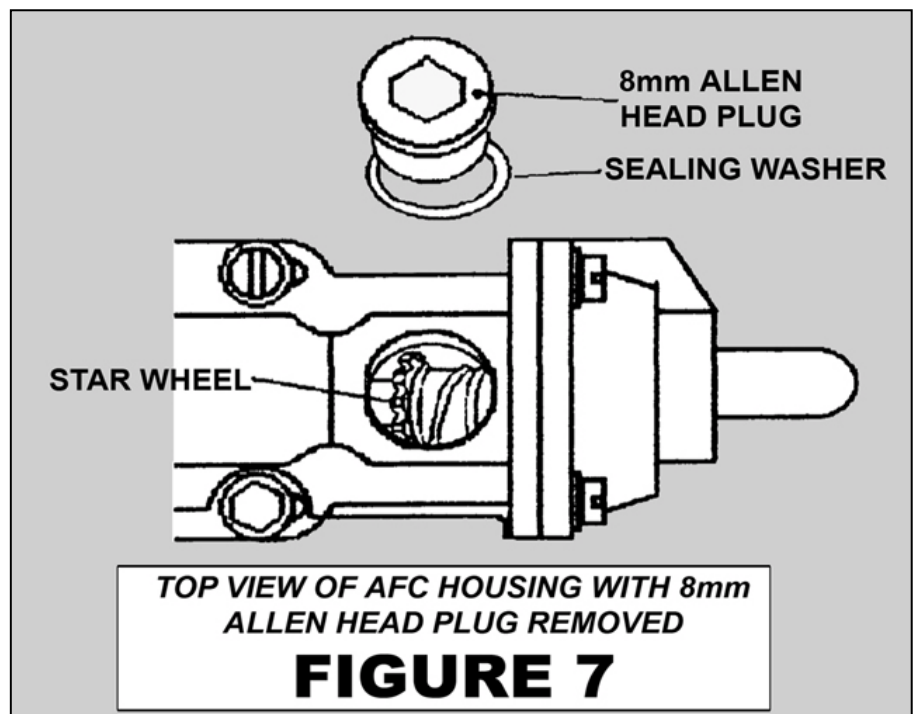

the sealing washer under the plug. Removing the plug exposes a star wheel, which changes the quickness of fueling response to boost. If the acceleration is weak with minimal smoke, rotate the top of the star wheel towards the engine a few revolutions. If the vehicle has heavy black smoke on initial acceleration, rotate the top of the star wheel away from the engine a few revolutions. Re-install the large plug with the sealing washer and test-drive the vehicle again. It may take a few repeated attempts to get this adjustment set. If the heavy smoke is still encountered with the star wheel moved completely to the rear position, go back to step 26, loosen the AFC housing and slide it rearward a 1/16" inch, re-tighten and test again. Repeat until desired results occur.

**38)** To make your installation look more professional, paint the new parts and chips on the screws and bolts with matching engine paint. Cummins paint part number 3822975 "blue" matches earlier engines that appear grayish-bluish-black. Later engines are painted with a glossy black 3824514 "titanium black".

**If you have any technical questions about this or other products, call the BD Sales & Technical Support Line at (800) 887-5030, Monday to Friday, 8:30am – 5:00pm PST.**