



## **BD Cummins 1988-93 VE Fuel Pin Kit**





**P/N# 1040178**

**PLEASE READ ALL INSTRUCTIONS BEFORE INSTALLATION**

*Please note this product has not been evaluated by the EPA or CARB so it is therefore illegal to use on road or off road. RACE USE ONLY.*

# **KIT CONTENTS:**

Please check to make sure that you have all the parts listed in this kit before you start the disassembly of your truck.

<b>1040178 Kit Contents</b>			
<b>1505015 Fuel Pin</b>			
			
<i>Fuel Pin</i>			
<b>Qty: 1</b>			
<b>1505016</b>	<b>1505017</b>	<b>1505020</b>	<b>1464650366</b>
			
<i>M6 x 1.0 Jam Nut</i>	<i>1.9mm Nylon Bushing</i>	<i>Throttle Shaft Oring</i>	<i>Gov Spring</i>
<b>Qty: 1</b>	<b>Qty: 1</b>	<b>Qty:1</b>	<b>Qty: 1</b>

## Welcome

Thank you for purchasing the Dodge Fuel Pin. This fuel pin is design for the 1988-93 Dodge Cummins with the VE pump. You will notice the quality of the fuel surpasses all others in the aftermarket. The pin is made from Chromalloy steel, hardened to factory specification and then precision ground.

Supplied in the kit is a Bosch 1.9mm bushing to give you even more power. This combination is designed to give you roughly additional 30HP and 80 ftlbs of torque. With the governor spring installed you will increase your available power band by roughly 500 RPM and increase HP by another 10HP over the fuel pin.

## Recommended Upgrades

Description	Part #
Cool Covers (Valve Covers)	1061800-6
Quick spool 16cm Exhaust housing	1045911
Pyro and Boost Gauge	Call

## Required Tools

- Ratchet
- Blade Screw Driver
- 13mm socket and wrench
- 17mm wrench
- Metric rounded tip allen key set (5mm)

BD Engine Brake Inc.

Plant Address: 33541 MacLure Rd. Abbotsford, BC, Canada V2S 7W2

U.S. Shipping Address: 88-446 Harrison St, Sumas, WA 98295 U.S. Mailing Address: P.O. Box 231, Sumas, WA 98295

Phone: 604-853-6096 | Fax: 604-853-8749 | Internet: [www.bd-power.com](http://www.bd-power.com)

## INSTALLATION

1. Clean off top and surrounding area of the VE injection pump.



2. Remove 12mm banjo from the rear of the AFC housing.

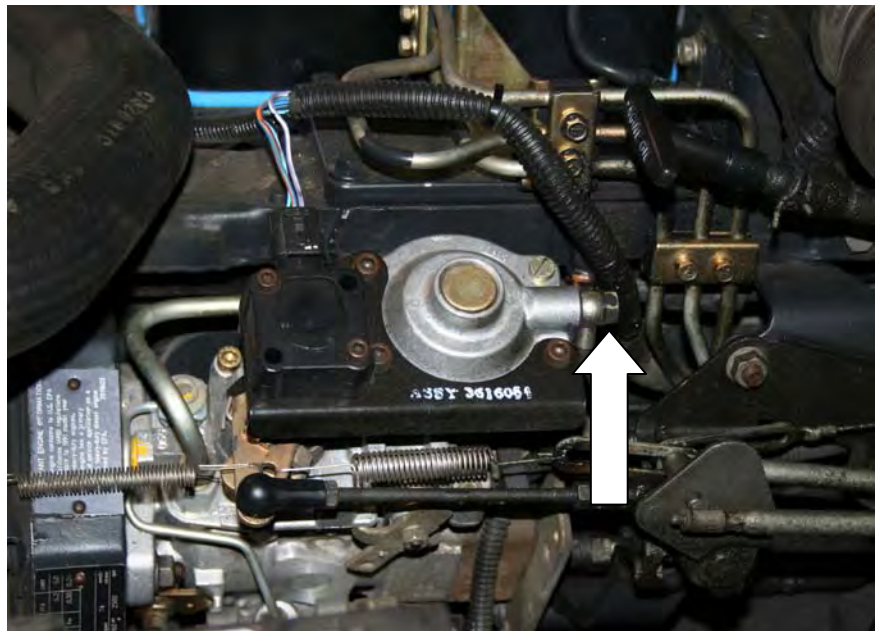

BD Engine Brake Inc.

Plant Address: 33541 MacLure Rd. Abbotsford, BC, Canada V2S 7W2

U.S. Shipping Address: 88-446 Harrison St, Sumas, WA 98295 U.S. Mailing Address: P.O. Box 231, Sumas, WA 98295

Phone: 604-853-6096 | Fax: 604-853-8749 | Internet: [www.bd-power.com](http://www.bd-power.com)

3. Remove APPS Sensor and bracket. Manual transmissions do not have an APPS.



4. Remove the four screws on the top of the AFC and remove the cover.



BD Engine Brake Inc.

Plant Address: 33541 MacLure Rd. Abbotsford, BC, Canada V2S 7W2

U.S. Shipping Address: 88-446 Harrison St, Sumas, WA 98295 U.S. Mailing Address: P.O. Box 231, Sumas, WA 98295

Phone: 604-853-6096 | Fax: 604-853-8749 | Internet: [www.bd-power.com](http://www.bd-power.com)

5. Remove diaphragm. Lift up slowly and carefully. You must keep this area very clean.



6. Remove the factory white nylon bushing. It may be stuck to the bottom of the diaphragm, or at its base in the fuel pump.



7. Remove the factory fuel pin from the diaphragm by using two 10mm wrenches. One on the jam nut the other on the rectangular slots on the fuel pin.

**DO NOT TEAR  
DIAPHRAGM.**

BD Engine Brake Inc.

Plant Address: 33541 MacLure Rd. Abbotsford, BC, Canada V2S 7W2

U.S. Shipping Address: 88-446 Harrison St, Sumas, WA 98295 U.S. Mailing Address: P.O. Box 231, Sumas, WA 98295

Phone: 604-853-6096 | Fax: 604-853-8749 | Internet: [www.bd-power.com](http://www.bd-power.com)

8. Swap the diaphragm, lock washer to the new fuel pin. Install newly supplied jam nut and secure the threads with blue loctite.



9. Before inserting new pin assembly, stroke the throttle linkage back and forth slightly. You can use some lubrication at the same time to assist you.

DO NOT FULLY STROKE THE APPS TO FULL THROTTLE. OTHERWISE THE GUIDE PIN MAY FALL OUT.

Once this is done you will need to push the guide pin back towards the front of the pump. This is easily done using a long thin tool.

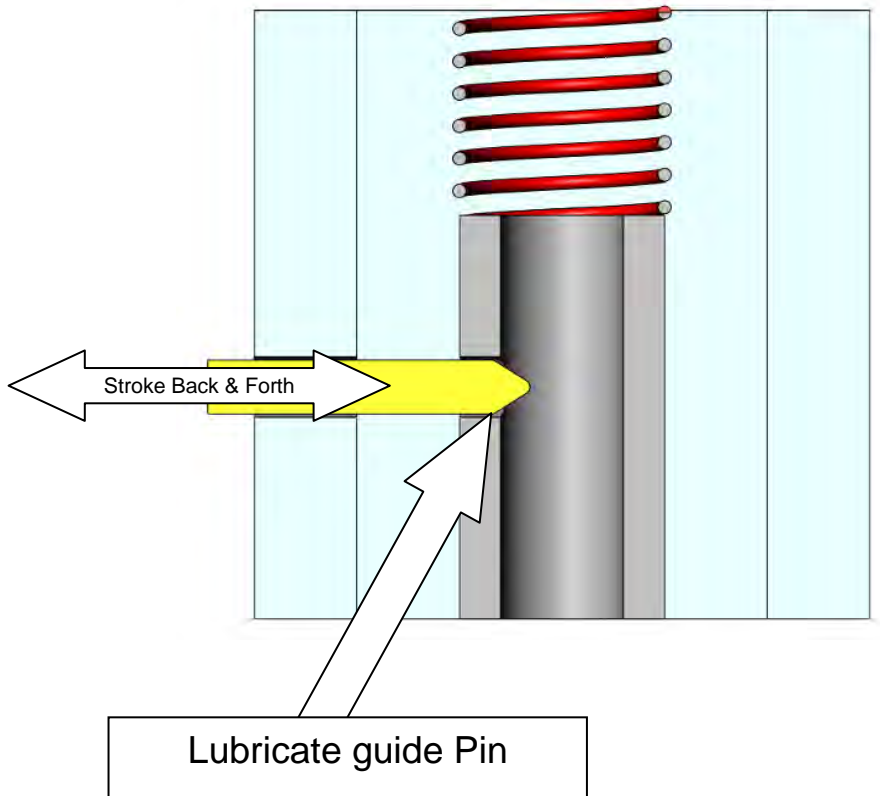

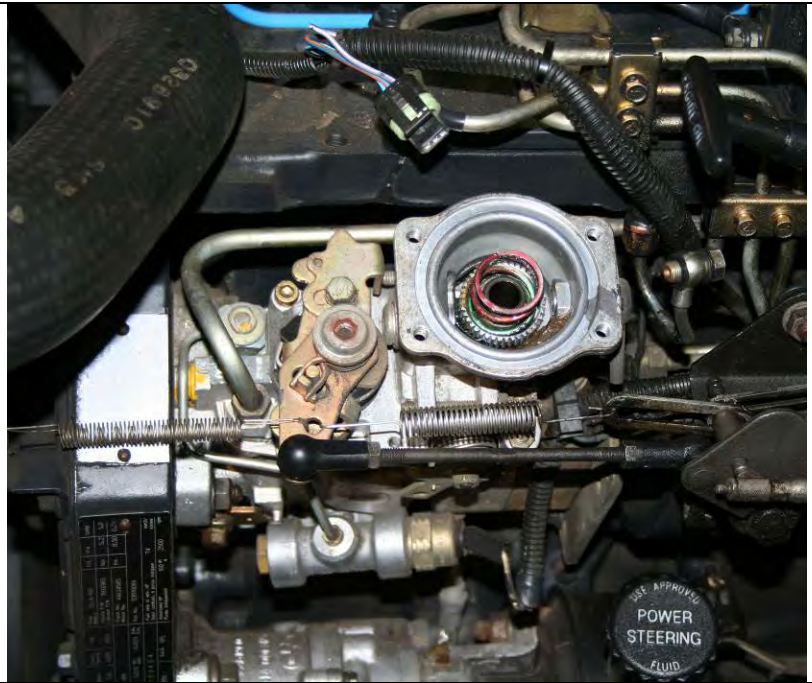

### GOVERNOR SPRING INSTALLATION POINT

Please note that if you are going to install the governor spring now is the time to do so. The governor installation instructions are at the end of the current section on page 11. Please keep in mind it is a complex installation and should only be performed by a trained individual.

10. Lubricate the pin with a small amount of diesel fuel, then install the new fuel pin assembly into the pump with the new nylon bushing. The bushing goes below the diaphragm.



11. Ensure the ground fuel pin profile faces directly forward. To ensure this, lift the fuel pin assembly slightly and stroke the accelerator linkage from 0% to 100%. Do this while twisting the fuel pin slightly. You will feel a point of no resistance or when the rotational movement comes to a center point. This is the correct alignment.

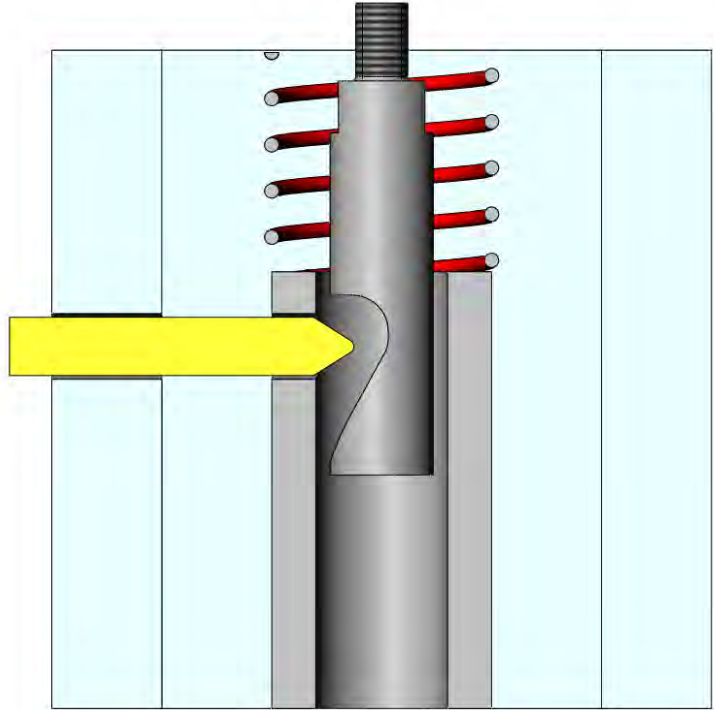

**Profile must face directly forward.**

12. Re-install the AFC using the 4 screws you removed earlier.



13. Re-install the APPS and the bracket, if so equipped.



14. Re-install the 12mm Banjo bolt at the rear of the AFC.

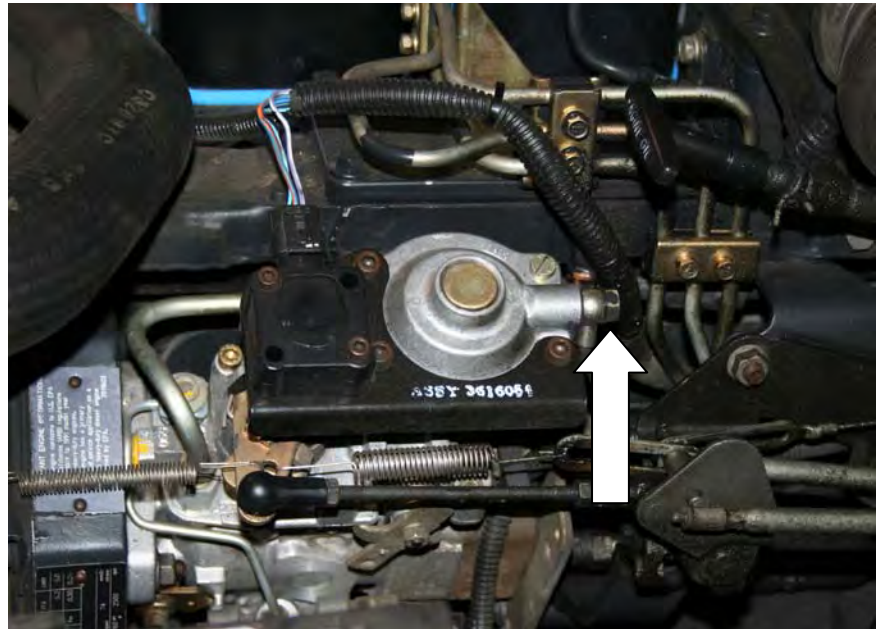

You should be all set to go. Take the truck for a test drive and ensure everything is working correctly.

## Governor Spring Installation

Please note that the governor spring installation is quite complex and should only be done by a trained technician.

1. Insert 8mm allen wrench into throttle lever. Remove the external throttle and kick down springs. Remove the 8mm screw, as well as the 2 washers.

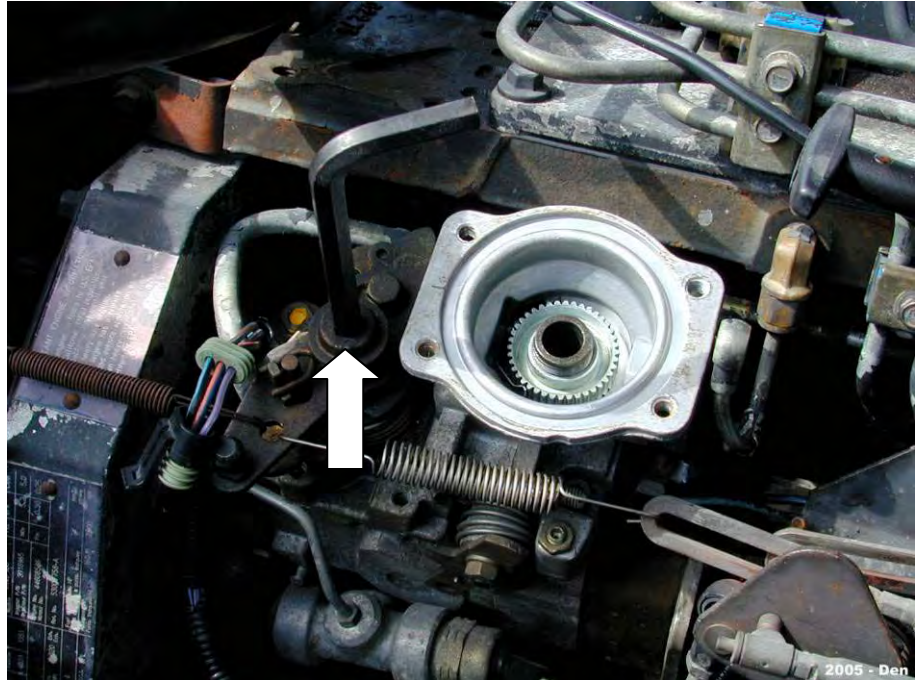

2. Before removing the throttle lever you will need to mark the lever's position on the splined throttle shaft.

99% of the time the mark is inline with the second groove.

Remove the throttle lever.

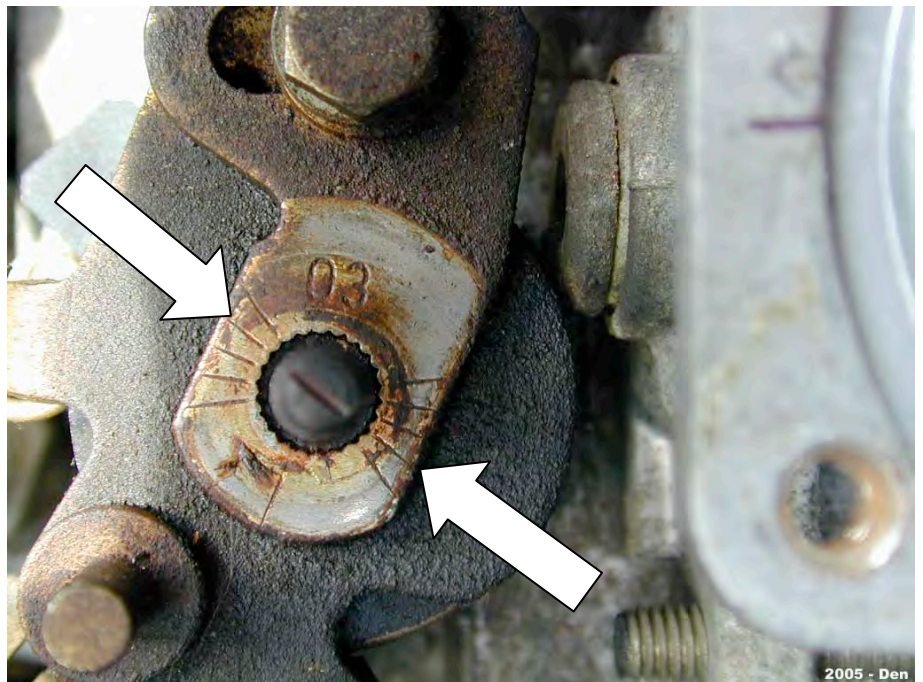

BD Engine Brake Inc.

Plant Address: 33541 MacLure Rd. Abbotsford, BC, Canada V2S 7W2

U.S. Shipping Address: 88-446 Harrison St, Sumas, WA 98295 U.S. Mailing Address: P.O. Box 231, Sumas, WA 98295

Phone: 604-853-6096 | Fax: 604-853-8749 | Internet: [www.bd-power.com](http://www.bd-power.com)

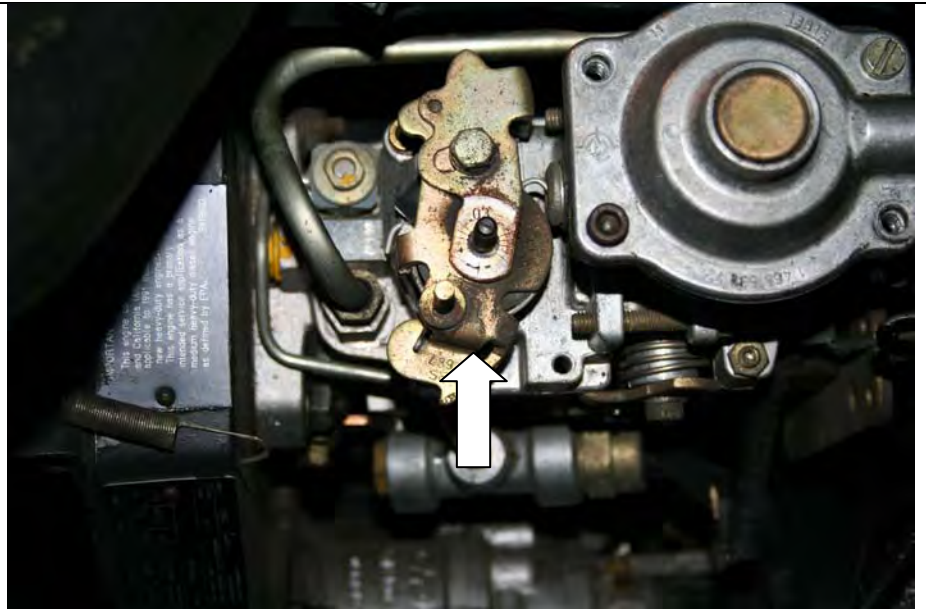

3. Remove the throttle return spring as well as the 2 plastic parts (top and bottom). Lift these off in one piece as they have to go back in place in the same order.

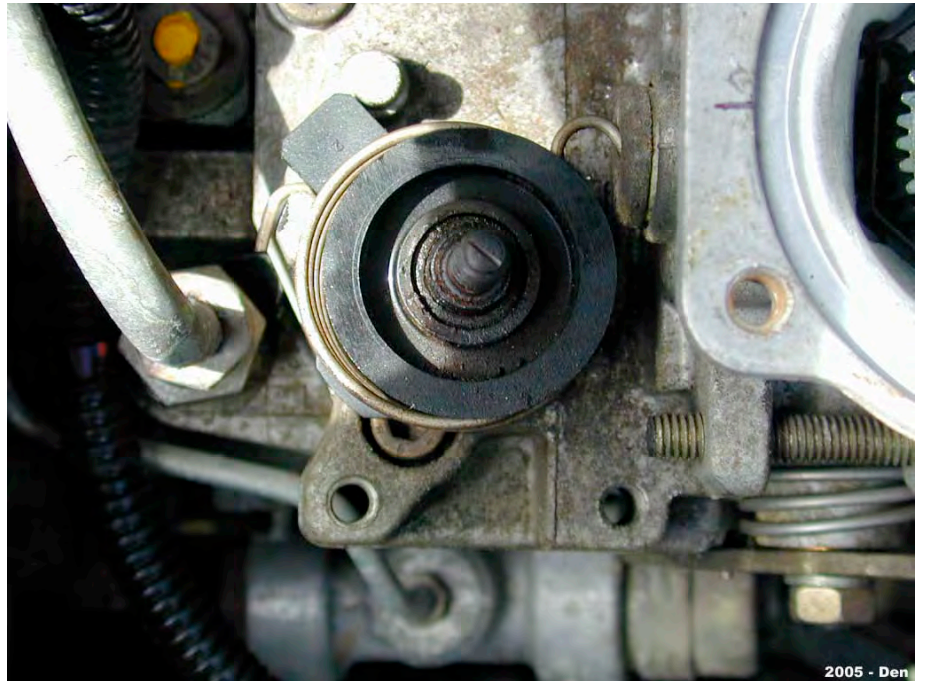

4. Remove the tamper proof cap on the high idle screw. Simply grab the cap with pliers or vice grips and pull towards the rear of the vehicle.

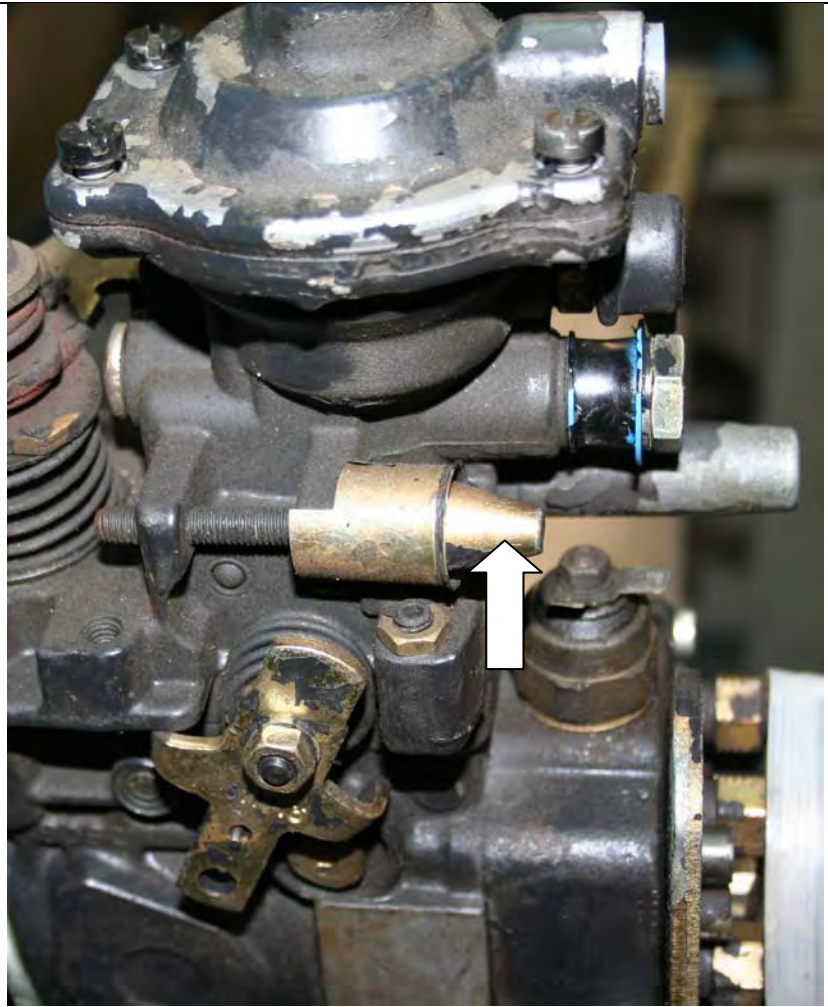

BD Engine Brake Inc.

Plant Address: 33541 MacLure Rd. Abbotsford, BC, Canada V2S 7W2

U.S. Shipping Address: 88-446 Harrison St, Sumas, WA 98295 U.S. Mailing Address: P.O. Box 231, Sumas, WA 98295

Phone: 604-853-6096 | Fax: 604-853-8749 | Internet: [www.bd-power.com](http://www.bd-power.com)

5. Using a 10mm socket, remove the jam nut that secures the remainder of the tamper proof cap. Throw away tamper proof cap pieces.

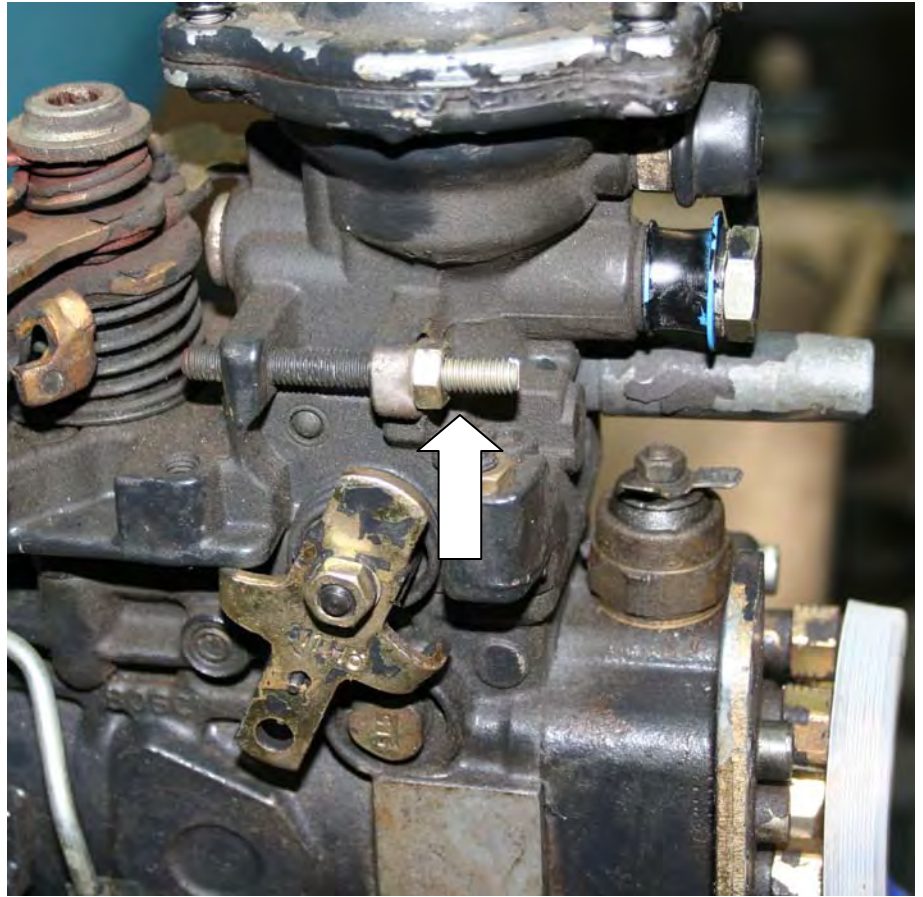

**Picture shows cap and extra jam nut removed.**

6. Next remove the other tamper proof cap on the main fuel screw. You can either use vice grips and a hammer or a blade screw driver and a hammer. Using vice grips, grip the cap near the end and tighten the vice grips. Then use the hammer to hit the vice grips towards the rear of the vehicle. This will break off the safety cap.



BD Engine Brake Inc.

Plant Address: 33541 MacLure Rd. Abbotsford, BC, Canada V2S 7W2

U.S. Shipping Address: 88-446 Harrison St, Sumas, WA 98295 U.S. Mailing Address: P.O. Box 231, Sumas, WA 98295

Phone: 604-853-6096 | Fax: 604-853-8749 | Internet: [www.bd-power.com](http://www.bd-power.com)

7. With the tamper proof cap removed, back the screw out until the oring is visible.



8. You will need to use a rounded tip 5mm allen key for the next step.



9. Using the rounded end of the allen key remove the 4 bolts holding the cover on. You will need to use a wrench on the end of the allen key as the bolts are quite tight.

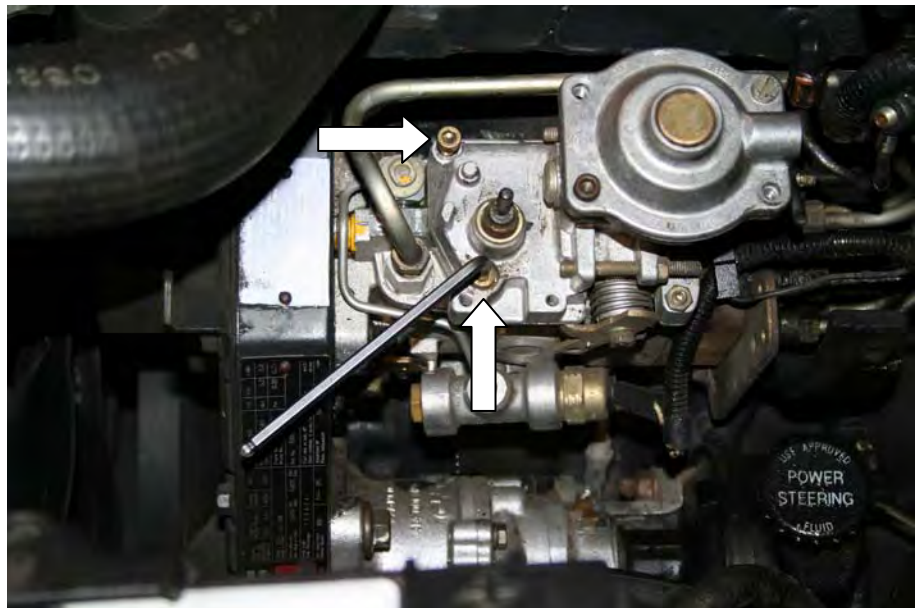



10. With the 4 bolts removed pull up on the cover while pushing down on the throttle shaft.



11. With the cover off you can now access the governor spring. Using your fingers just replace the spring. Be careful as one end is under spring tension.



BD Engine Brake Inc.

Plant Address: 33541 MacLure Rd. Abbotsford, BC, Canada V2S 7W2

U.S. Shipping Address: 88-446 Harrison St, Sumas, WA 98295 U.S. Mailing Address: P.O. Box 231, Sumas, WA 98295

Phone: 604-853-6096 | Fax: 604-853-8749 | Internet: [www.bd-power.com](http://www.bd-power.com)



12. Replace oring on throttle shaft, with the oring supplied (#1505020).

Do not damage the oring, it will help if you have a small pick to remove and install the new oring.



13. Slide the throttle shaft through the top cover.



14. With the spring back in place, hold the governor spring assembly in position so that you can replace the top cover. Tighten the four cap screw bolts.

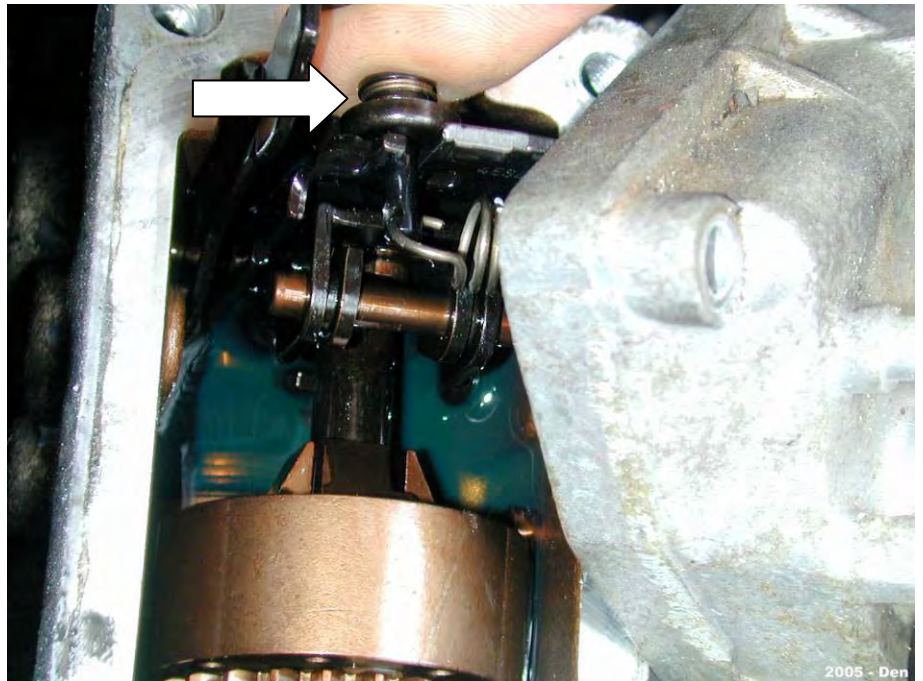

15. Install the throttle shaft spring assembly. Hook the bottom spring hook in and then the lower plastic piece will hold it in place. Pull up on the throttle shaft to get it in position.



16. Now tighten the main fuel screw back in to the previous position.

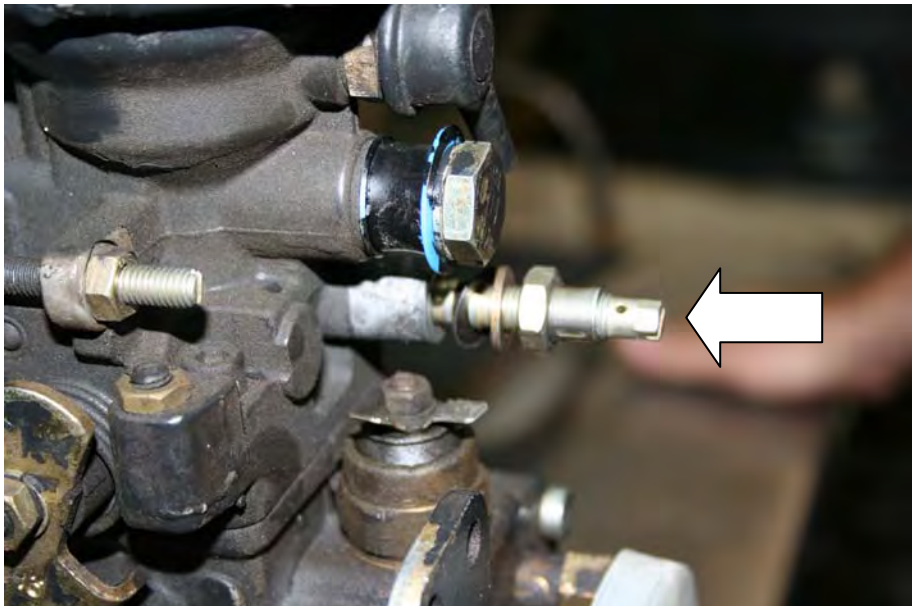

17. Place plastic spring assembly into place.

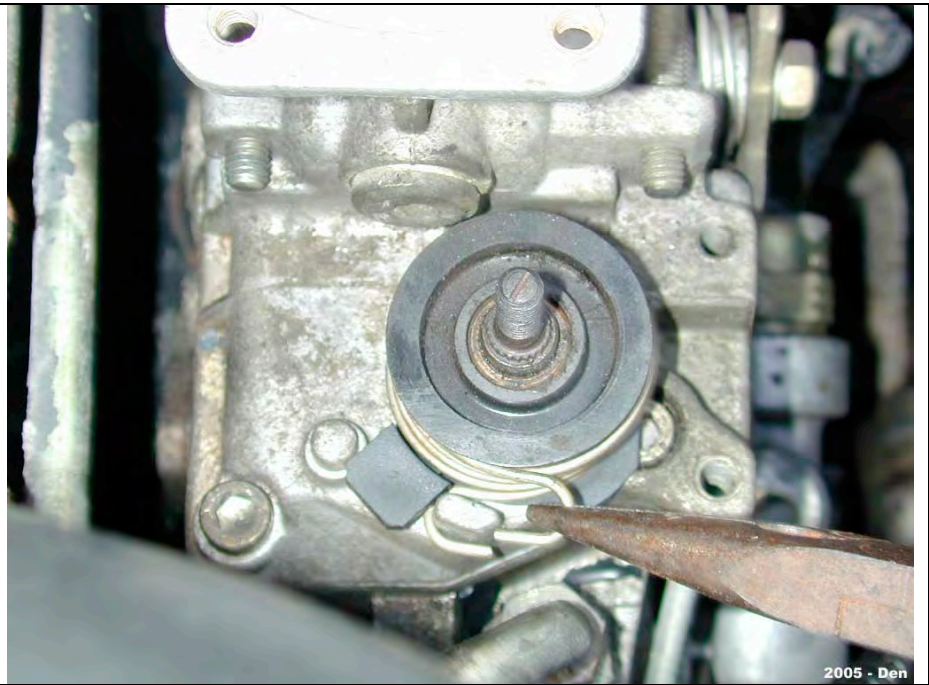

18. Remember to align the correct alignment notches/lines on the shaft to the lower lever.

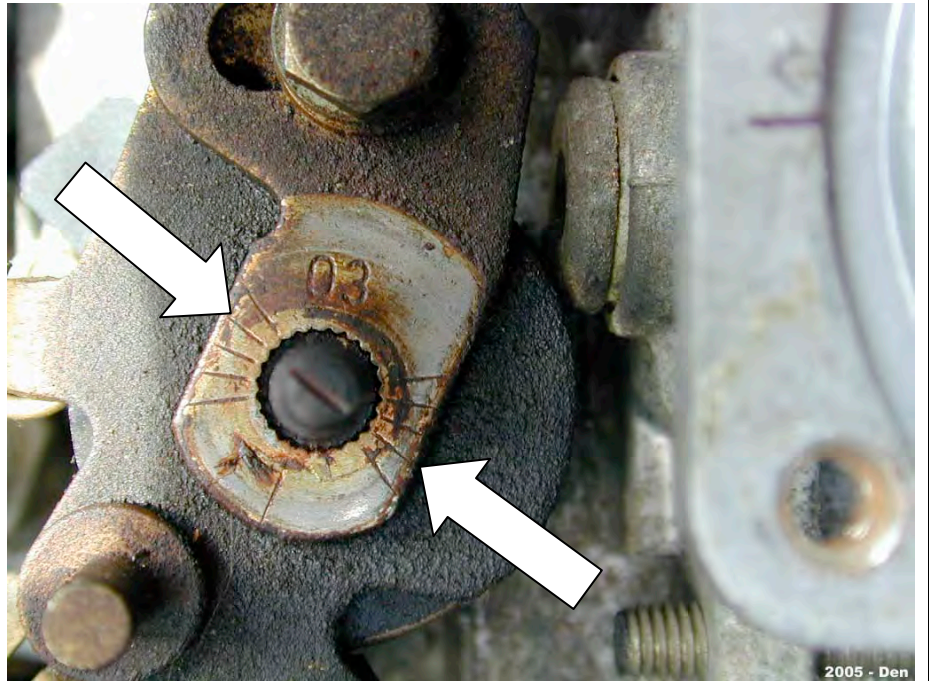

BD Engine Brake Inc.

Plant Address: 33541 MacLure Rd. Abbotsford, BC, Canada V2S 7W2

U.S. Shipping Address: 88-446 Harrison St, Sumas, WA 98295 U.S. Mailing Address: P.O. Box 231, Sumas, WA 98295

Phone: 604-853-6096 | Fax: 604-853-8749 | Internet: [www.bd-power.com](http://www.bd-power.com)

19. You will need to pull the spring around the back side of the lever so that it locks into place. A handy trick is to use some wire and pull the spring tab around into place.

20. Install the two washers. The steel one first and then the plastic one. Make sure the plastic one is around the steel one.

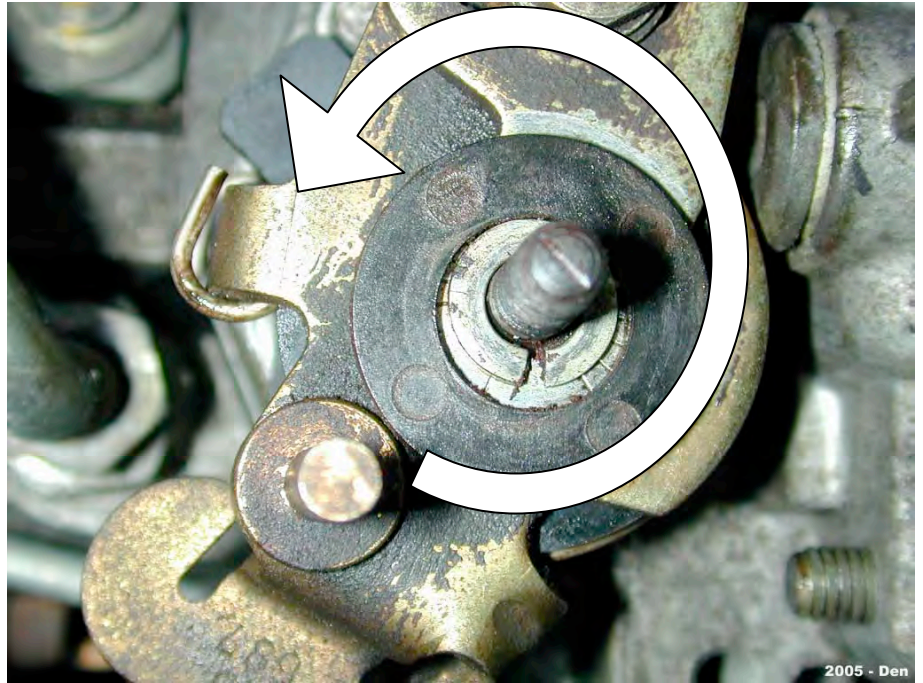

21. Clean and grease the bolt and place it back into the lever and install the top lever.

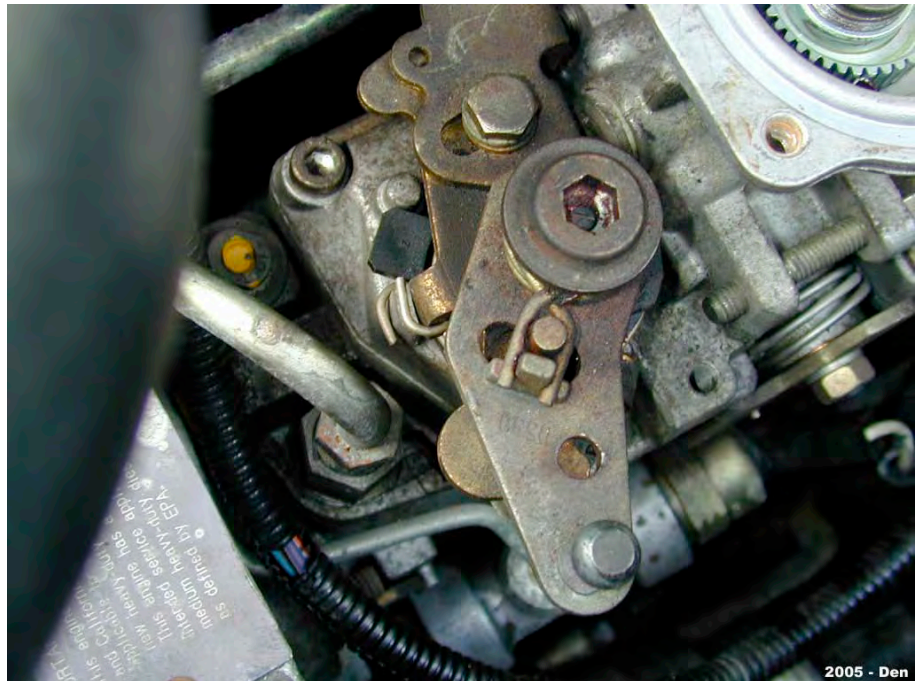

You can return to the fuel pin section to complete the installation on page 8.

BD Engine Brake Inc.

Plant Address: 33541 MacLure Rd. Abbotsford, BC, Canada V2S 7W2

U.S. Shipping Address: 88-446 Harrison St, Sumas, WA 98295 U.S. Mailing Address: P.O. Box 231, Sumas, WA 98295

Phone: 604-853-6096 | Fax: 604-853-8749 | Internet: [www.bd-power.com](http://www.bd-power.com)

## *Troubleshooting*

If you have any technical difficulties, concerns, comments, or complaints, please phone our Technical Support hotline at (800) 887-5030 between 8:30am-5:00pm PST (Pacific Standard Time) Monday to Friday, or post a message on the BD Discussion Forums located at:

<http://forum.bd-power.com/>



Visit our Internet forums at <http://www.dieselperformance.com> and share your comments or technical support questions with some of the industry's leading experts in the diesel field.

BD Engine Brake Inc.

Plant Address: 33541 MacLure Rd. Abbotsford, BC, Canada V2S 7W2

U.S. Shipping Address: 88-446 Harrison St, Sumas, WA 98295 U.S. Mailing Address: P.O. Box 231, Sumas, WA 98295

Phone: 604-853-6096 | Fax: 604-853-8749 | Internet: [www.bd-power.com](http://www.bd-power.com)