





2008-09 6.7 Dodge Cummins **Positive Air Shutoff**

P/N#	1036723
P/N#	1036723-M

PLEASE READ ALL INSTRUCTIONS BEFORE INSTALLATION

KIT CONTENTS:

Please check to make sure that you have all the parts listed in this kit **before** you start the disassembly of your truck.

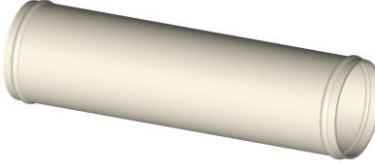

1036723 Kit Contents			
1302300	1302275	1302262-R	1302273
			
<i>Air Shutoff Valve</i>	<i>Wiring Harness</i>	Straight pipe	<i>3.25-3.50 Silicone Boot</i>
Qty: 1	Qty: 1	Qty: 1	Qty: 1
1302267	1405212	1407030	1405211
			
<i>90° Boot</i>	<i>0378 Clamps</i>	<i>0350 Clamps</i>	<i>0325 Clamp</i>
Qty: 1	Qty: 1	Qty: 2	Qty: 2
1800060	1301381	1306720	1302285
			
<i>Velcro strips</i>	<i>Heat Shrink</i>	<i>6.7 Electronic Module</i>	<i>Solder</i>
Qty: 2 x 4"	Qty: 3"	Qty: 1	Qty: 5"

BD Engine Brake Inc.

Plant Address: 33541 MacLure Rd. Abbotsford, BC, Canada V2S 7W2

U.S. Shipping Address: 88-446 Harrison St, Sumas, WA 98295 U.S. Mailing Address: P.O. Box 231, Sumas, WA 98295

Phone: 604-853-6096 | Fax: 604-853-8749 | Internet: www.bd-power.com

1036723-M Kit Contents			
1302300		1302249	
			
<i>Air Shutoff Valve</i>		<i>Wiring Harness</i>	
Qty: 1		Qty: 1	
		1302273	
			
		<i>3.25-3.50 Step Boot</i>	
		Qty: 1	
1302267	1405212	1407030	1405211
			
<i>90° Boot</i>	<i>0378 Clamps</i>	<i>0350 Clamps</i>	<i>0325 Clamp</i>
Qty: 1	Qty: 1	Qty: 2	Qty: 2
1302262-R			
			
<i>Straight pipe</i>			
Qty: 1			

WELCOME

Thank you for purchasing a BD positive air shutoff. This manual is divided into different areas to assist you with your installation and operation of your positive Air shutoff.

This product is a safety product and should be tested often.

Installation should occur on a vehicle properly secured to prevent rolling.

TABLE OF CONTENTS

1036723 Kit Contents	2
1036723-M Kit Contents	3
REQUIRED TOOLS.....	4
MAINTENANCE.....	5
INSTALLATION with OVER SPEED ELECTRONICS (1036723).....	5
INSTALLATION without OVER SPEED ELECTRONICS (1036723-M).....	14
WIRING DIAGRAM with OVER SPEED ELECTRONICS (1036723)	20
WIRING DIAGRAM without OVER SPEED ELECTRONICS (1036723-M)	22
RESETTING THE VALVE.....	23
SETUP, TESTING AND VERIFICATION with OVER SPEED ELECTRONICS.....	24
Automatic Mode (Pre Configured RPM)	24
Manual Mode (User Configured RPM)	26
TESTING FLOW CHART with OVER SPEED ELECTRONICS	29
TESTING FLOW CHART without OVER SPEED ELECTRONICS	30
LED OPERATION.....	31

REQUIRED TOOLS

- Frequency/Voltmeter (Optional)
- Needle Nose Pliers
- 1/2" Unibit
- Electrical Tape
- Soldering Iron
- Air or Manual Ratchet
- 7/16", 1/2" Sockets
- Wire Strippers
- Heat Gun

BD Engine Brake Inc.

Plant Address: 33541 MacLure Rd. Abbotsford, BC, Canada V2S 7W2

U.S. Shipping Address: 88-446 Harrison St, Sumas, WA 98295 U.S. Mailing Address: P.O. Box 231, Sumas, WA 98295

Phone: 604-853-6096 | Fax: 604-853-8749 | Internet: www.bd-power.com

MAINTENANCE

No maintenance is needed other than check to make sure the valve is acting correctly. Please see the testing section later in the manual for the correct procedure.

INSTALLATION with OVER SPEED ELECTRONICS (1036723)

VEHICLE SHOULD BE SAFELY SECURED BEFORE INSTALLATION.

1. Block the wheels of the vehicle to prevent the vehicle from rolling.

Open the hood.

2. Remove driver's side charge air cooler (CAC) pipe using a 7/16" socket and ratchet to loosen clamps.

Note: Keep all spring clamps and stock boots.

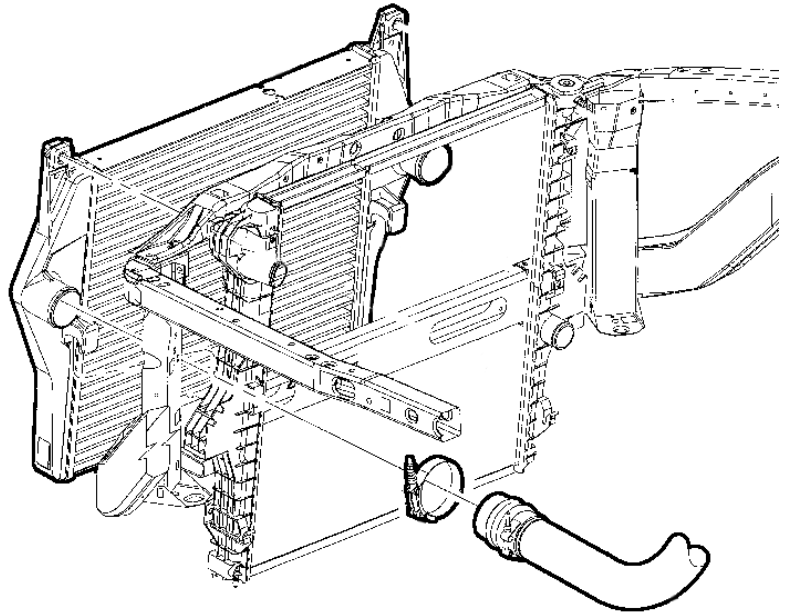

BD Engine Brake Inc.

Plant Address: 33541 MacLure Rd. Abbotsford, BC, Canada V2S 7W2

U.S. Shipping Address: 88-446 Harrison St, Sumas, WA 98295 U.S. Mailing Address: P.O. Box 231, Sumas, WA 98295

Phone: 604-853-6096 | Fax: 604-853-8749 | Internet: www.bd-power.com

2008-09 6.7L Installation Note

On 2008-09 6.7L vehicles you will notice that the factory silicone intercooler boots are permanently connected to the CAC inlet and outlet tubes. You will need to cut off the swedged pinch ring with a cut off wheel. Be sure not to damage the inlet and outlet pipe in the process.

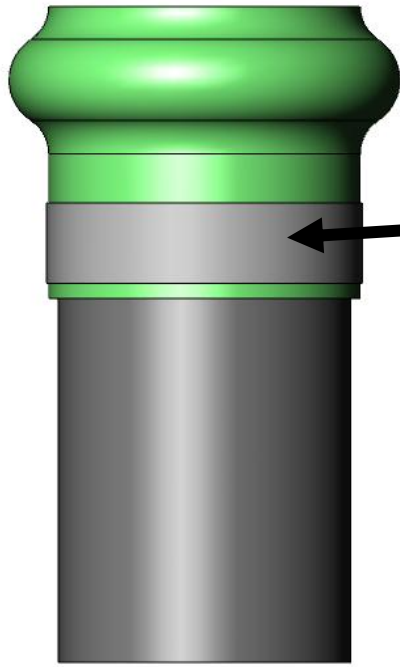

Cut swedged pinch ring to release silicone boot. Do not damage pipe in the process.

Once the pinch ring has been cut you can slide off the silicone boot.

3. Connect the stock boot to the supplied straight pipe and the 90° boot using the supplied 0325 (1405211) clamps as shown in diagram.

Then connect the 1302273 boot to the PAS valve using the provided 0350 (1407030) clamps.

Note: Leave clamps loose to allow movement.

With both assemblies completed, install the stock boot to the Charge Air Cooler.

Then install the valve assembly with clamp 0378 (1405212) onto the intake horn rotating the solenoid on the valve toward the inner fender.

Finally connect the two assemblies into place using the 0350 (1407030) clamp and tighten all clamps till springs are bound.

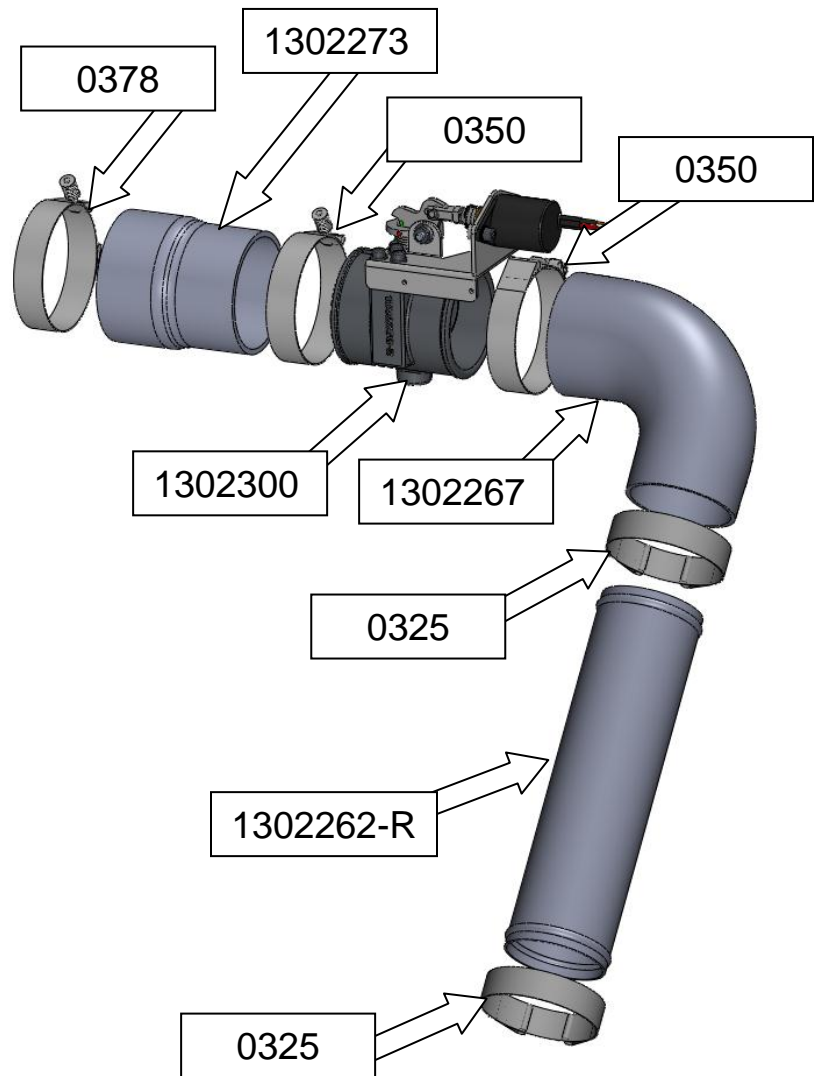

4. Lay out supplied harness over top of the driver's side of the engine.

You will then need to route the switch wires through the firewall (note you will need to remove the switch from the harness to accomplish this).

Choose a highly visible location for the switch and mount it to the dash.

Using a 1/8" drill, drill a pilot hole in the location you have selected for the switch to be mounted.

Finally using a 1/2" UNIBIT drill bit, drill an exact 1/2" round hole.

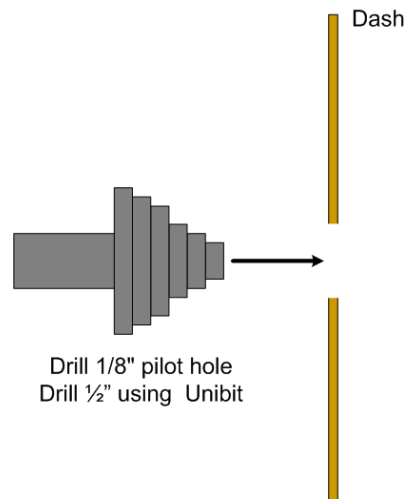
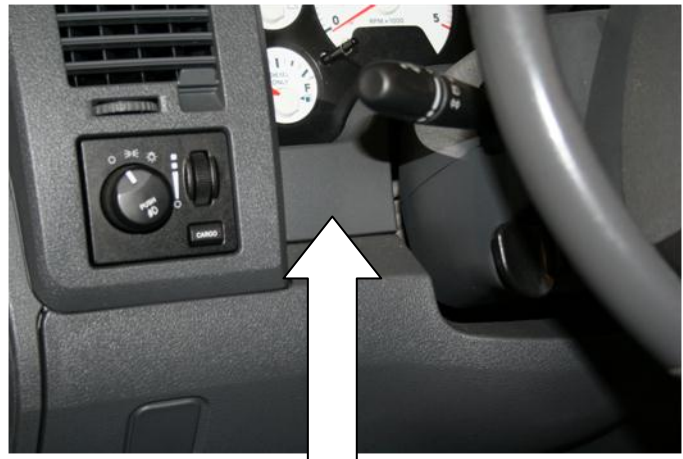

5. Once you have the mounting hole drilled, insert the switch from the backside.

Reinstall the correct wires to the correct switch terminals.

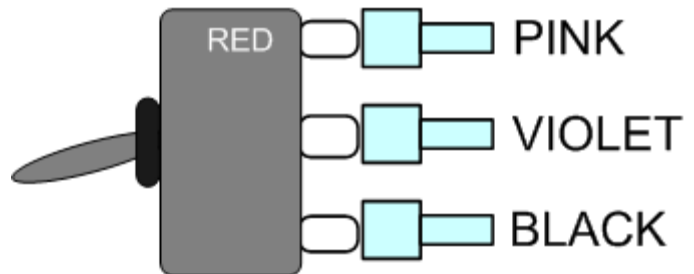

6. Mount the switch so that the groove on thread boss is facing down.

Adjust the HEX washer/nut so that the switch threads do not protrude an unsightly amount.

Then apply the supplied sticker and finally install the round plastic nut.

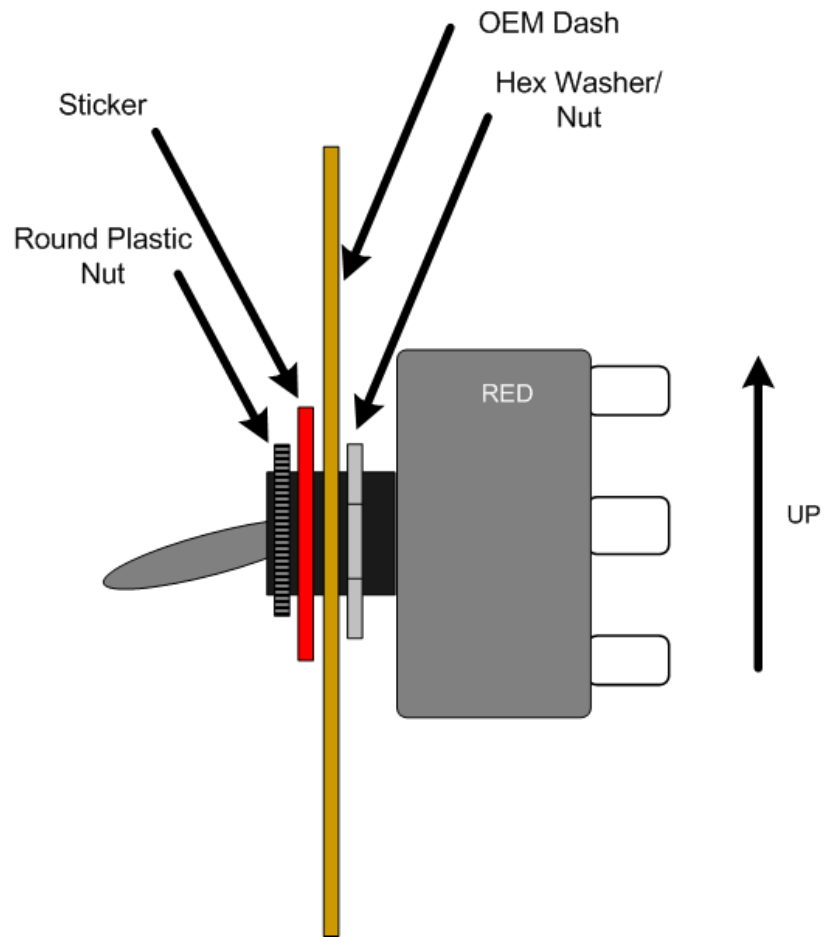

7. Locate and connect the weather pack connector on the wiring harness to the solenoid on the PAS valve.

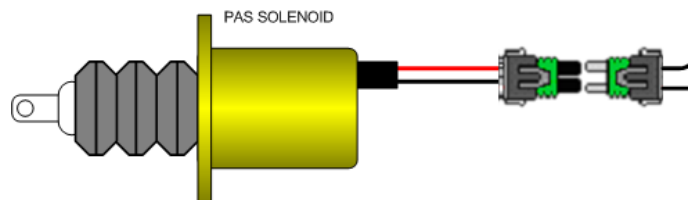

8. On the driver's side of the engine near the bottom, locate the ECM. Then locate connector C1 (closest to front of engine).

Locate Pin 31 (CKP Sensor), the wire will be Brown w/ Light Blue Tracer or on some trucks Light Blue w/ Brown tracer.

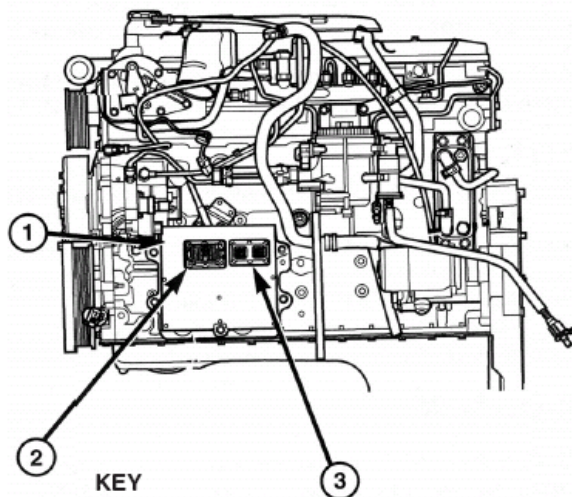

Pin 31	Brown w/Light Blue
--------	--------------------

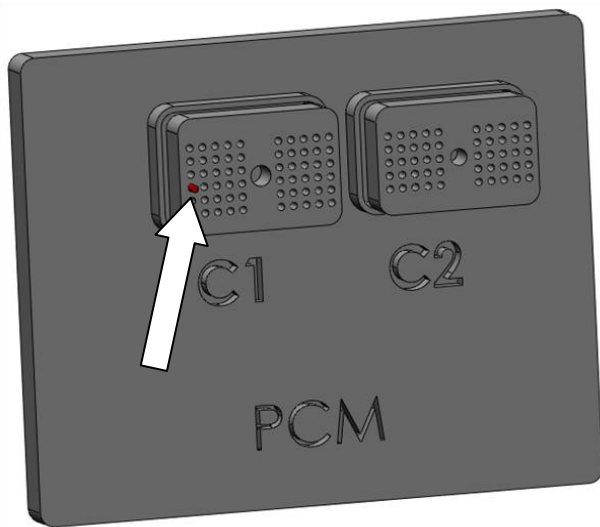

9. Being that the RPM signal is critical you will need to solder the connection.

Using wire strippers create a 1" window/gap in insulation of the wire.

Then strip about 1" of insulation of the RPM signal wire of the BLUE wire from the PAS wiring harness.

Wrap the copper wire around the factory RPM signal wire and solder this connection.

Then use electrical tape to wrap this connection so that it is water tight.

You can also cut the factory crank signal wire and use heat shrink tubing if you would like.

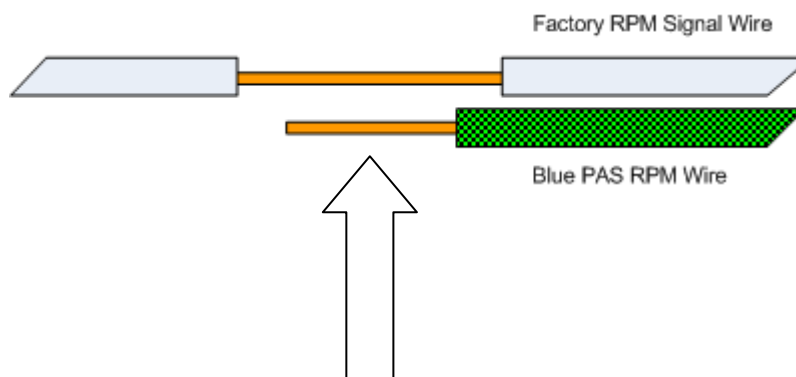

Solder the connection and then wrap and seal with electrical tape

10. Next on the wiring harness connection the BLACK and RED wires to the respective battery connections (Driver's Side Battery).

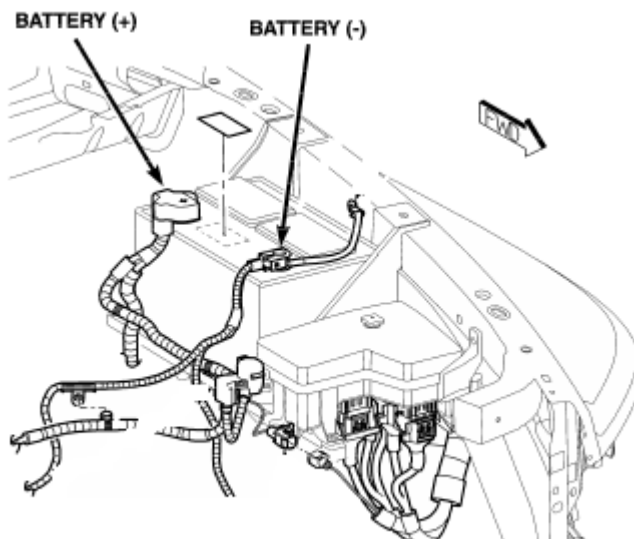

11. For the last connection you will need to locate ignition power. This will power the automatic over speed control box LED switch. Note that they unit can still be activated manually with the switch at any time.

Locate the fuse panel in front of the driver's side battery. Remove the cover.

Locate appropriate fused ignition power circuit (see table below). Install fuse tapper on to fuse #33 and reinstall fuse. Connect yellow lead wire with flag connector to this new connection. Route wire out of fuse box and close lid.

2008-09 Model Year

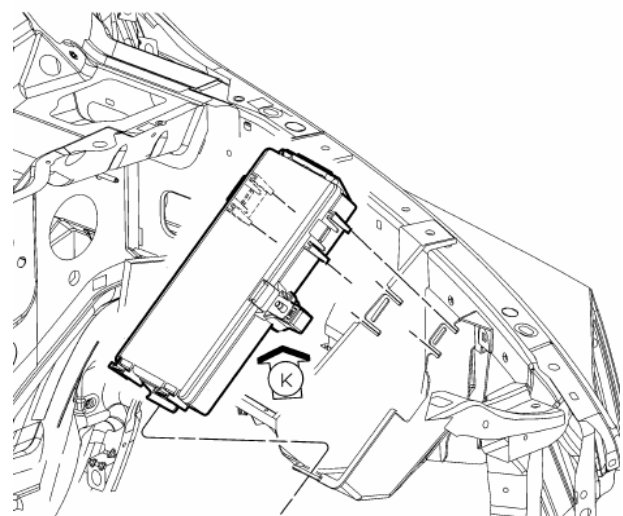
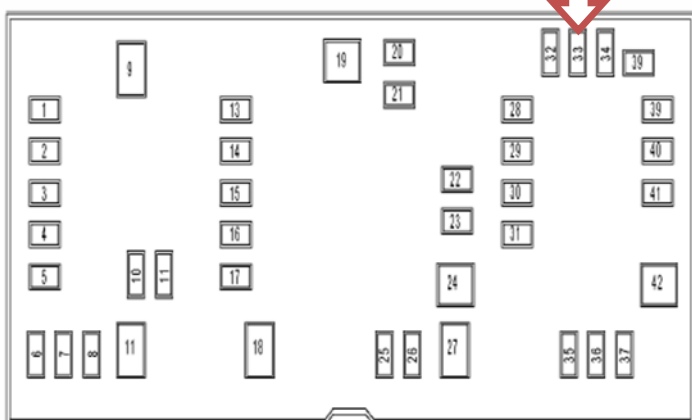

Fuse # 33 (10Amp)

12. With the fuse box closed, mount the control module on top of it using the supplied Velcro.

Be sure to clean both surfaces with rubbing alcohol before apply velcro.

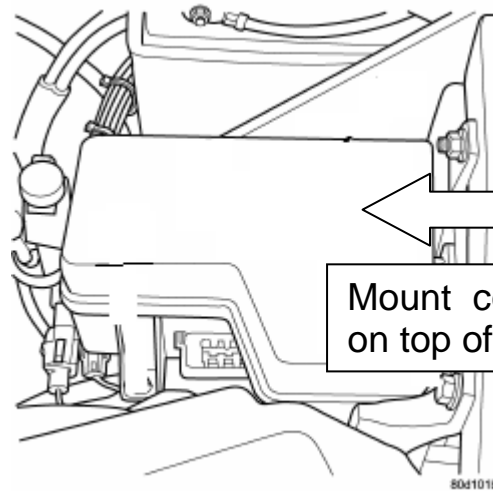

Mount control module on top of fuse box.

13. Double check all wiring connections and ensure wires are routed away from any heat sources and moving parts.

BD Engine Brake Inc.

Plant Address: 33541 MacLure Rd. Abbotsford, BC, Canada V2S 7W2

U.S. Shipping Address: 88-446 Harrison St, Sumas, WA 98295 U.S. Mailing Address: P.O. Box 231, Sumas, WA 98295

Phone: 604-853-6096 | Fax: 604-853-8749 | Internet: www.bd-power.com

INSTALLATION without OVER SPEED ELECTRONICS (1036723-M)

VEHICLE SHOULD BE SAFELY SECURED BEFORE INSTALLATION.

1. Block the wheels of the vehicle to prevent the vehicle from rolling.

Open the hood.

2. Remove Driver's side charge air cooler (CAC) pipe and CAC silicone boot using a 7/16" socket and ratchet.

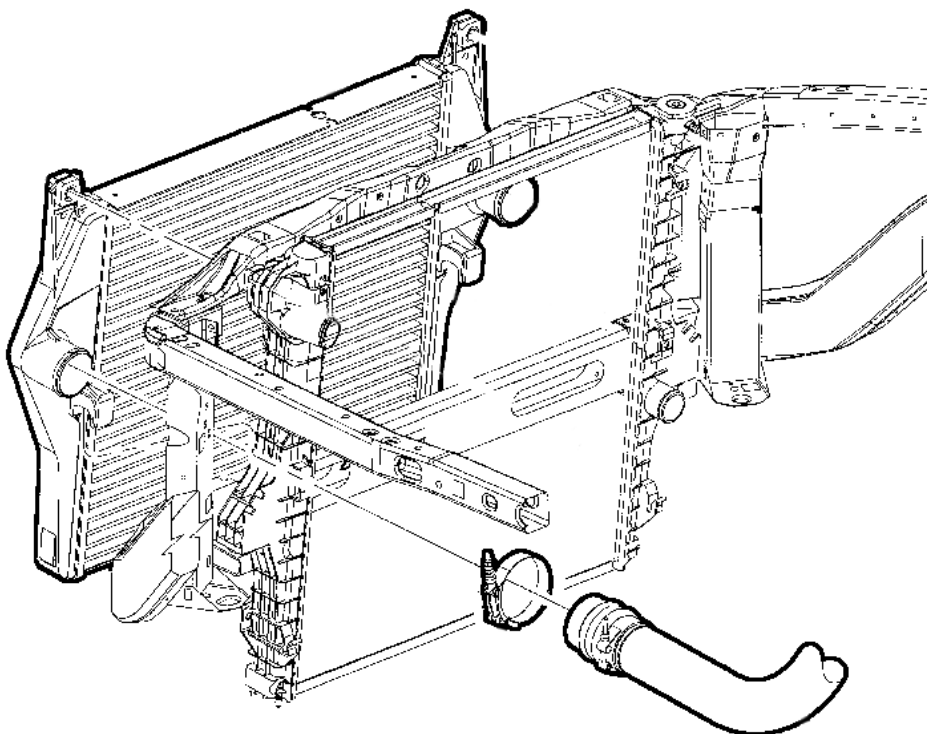

2008-09 6.7L Installation Note

On 2008-09 6.7L vehicles you will notice that the factory silicone intercooler boots are permanently connected to the CAC inlet and outlet tubes. You will need to cut off the swedged pinch ring with a cut off wheel. Be sure not to damage the inlet and outlet pipe in the process.

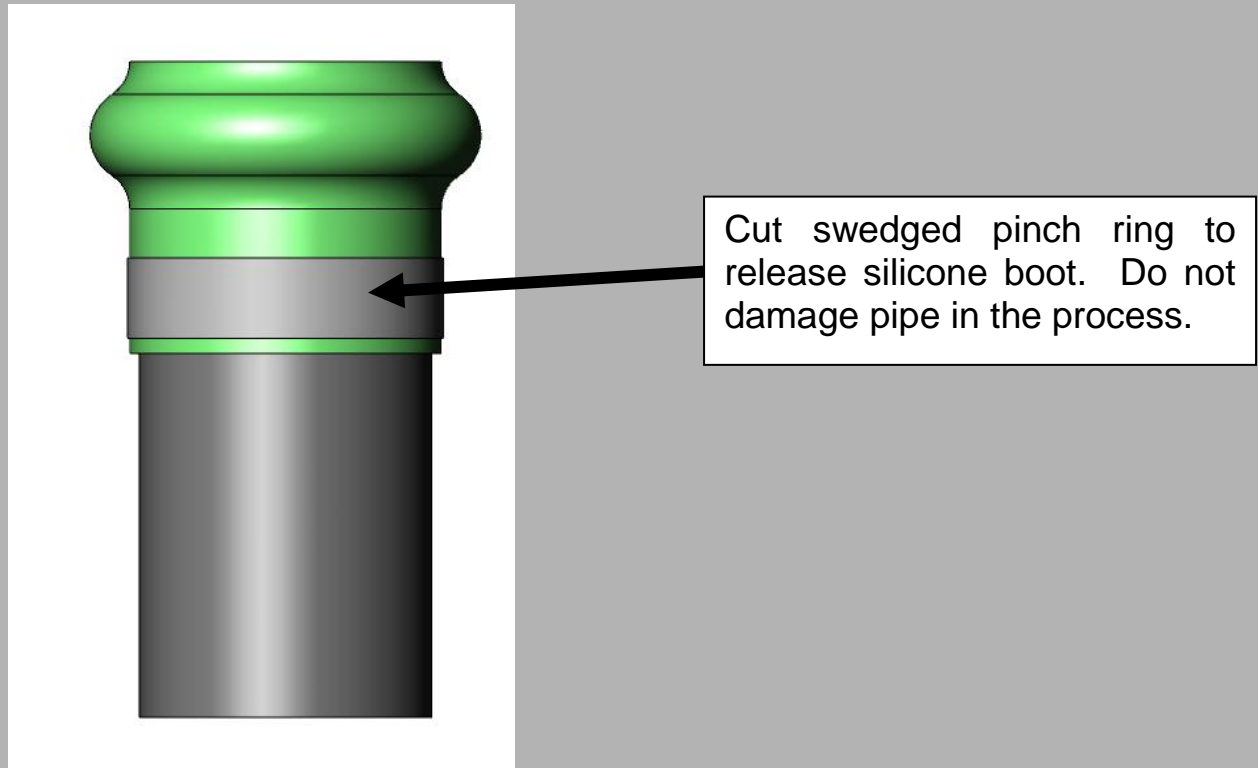

Once the pinch ring has been cut you can slide off the silicone boot.

INSTALLATION without OVER SPEED ELECTRONICS

3. Connect the stock boot to the supplied straight pipe and the 90° boot using the supplied 0325 (1405211) clamps as shown in diagram.

Then connect the 1302273 boot to the PAS valve using the provided 0350 (1407030) clamps.

Note: Leave clamps loose to allow movement.

With both assemblies completed, install the stock boot to the Charge Air Cooler.

Then install the valve assembly with clamp 0378 (1405212) onto the intake horn rotating the solenoid on the valve toward the inner fender.

Finally connect the two assemblies into place using the 0350 (1407030) clamp and tighten all clamps till springs are bound.

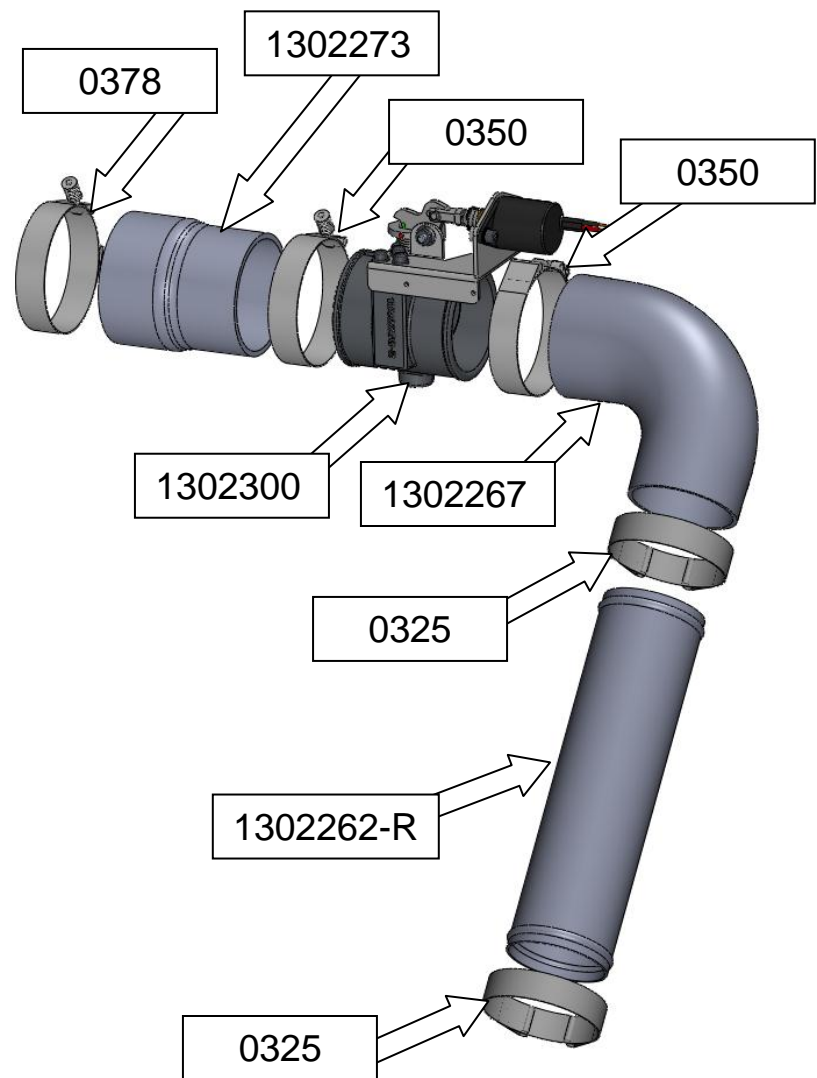

- Lay out supplied harness over top of the driver's side of the engine.

Locate and connect the weather pack connector on the wiring harness to the solenoid on the PAS valve.

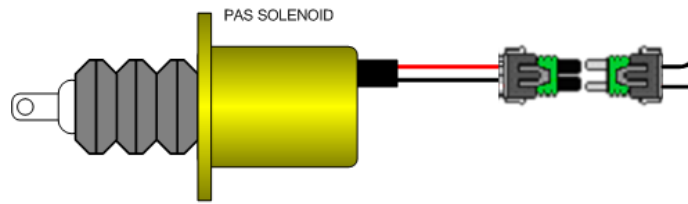

- You will then need to route the switch wires through the firewall.

Choose a highly visible location for the switch and mount it to the dash.

NOTE: You may need to trim the switch wires to length once you have located where the switch is to be mounted.



Using a 1/8" drill, drill a pilot hole in the location you have selected for the switch to be mounted.

Finally using a 1/2" UNIBIT drill bit, drill an exact 1/2" round hole.

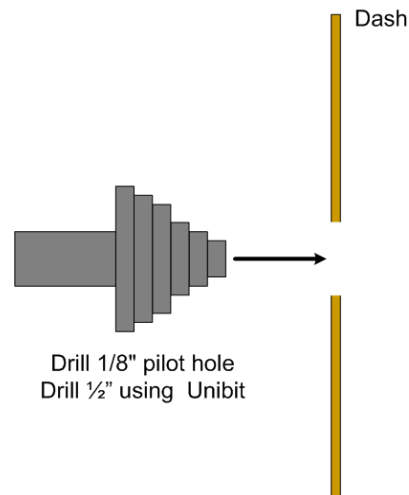

6. Once you have the mounting hole drilled, crimp the switch connectors to the switch wires and install the correct switch wires to the correct switch terminals, then insert the switch into the dash from the backside.

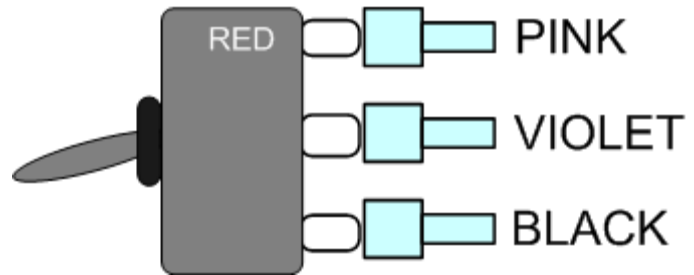

7. Mount the switch so that the groove on thread boss is facing down.

Adjust the HEX washer/nut so that the switch threads do not protrude an unsightly amount.

Then apply the supplied sticker and finally install the round plastic nut.

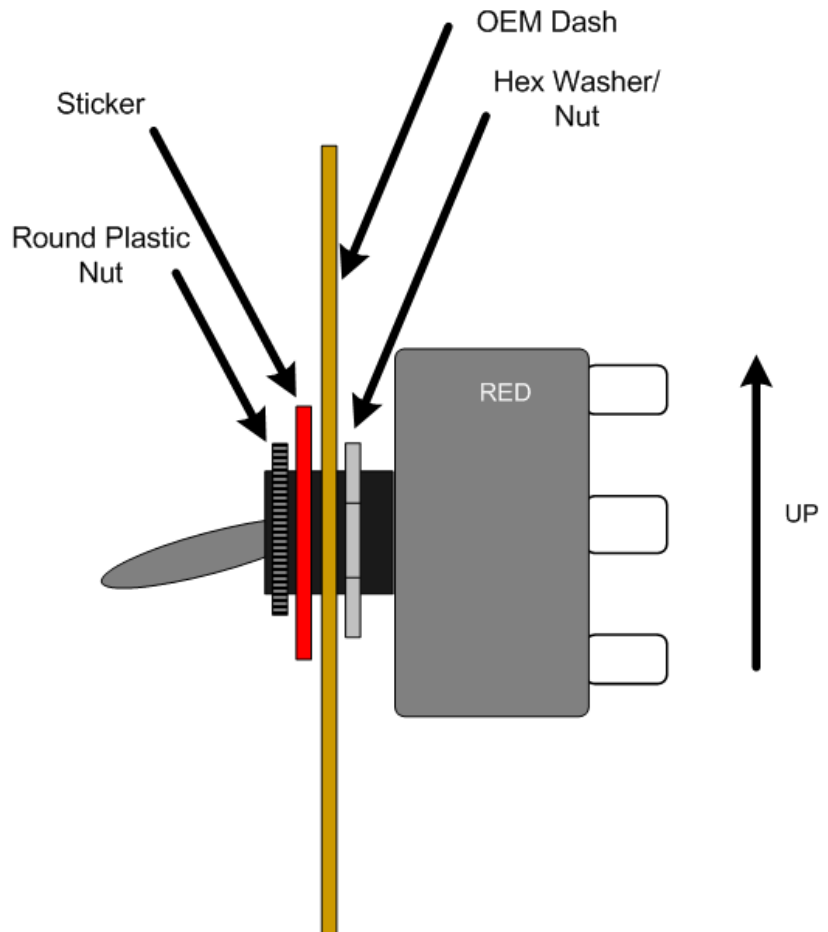

- 8. Next trim the wires to length and crimp the ring terminals to the BLACK and RED wires to connect to the respective battery connections.
(Driver side battery)

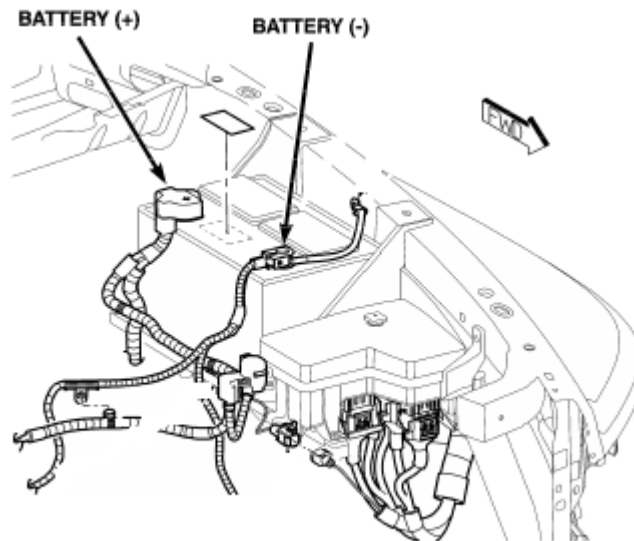

- 9. For the last connection you will need to locate ignition power.

Locate the fuse panel in front of the driver's side battery. Remove the cover.

Locate appropriate fused ignition power circuit (see table below). Install fuse tapper on to fuse #33 and reinstall fuse. Trim the pink wire to length and crimp the flag connector to the wire and connect the pink lead wire with flag connector to this new connection. Route wire out of fuse box and close lid.

2008-09 Model Year

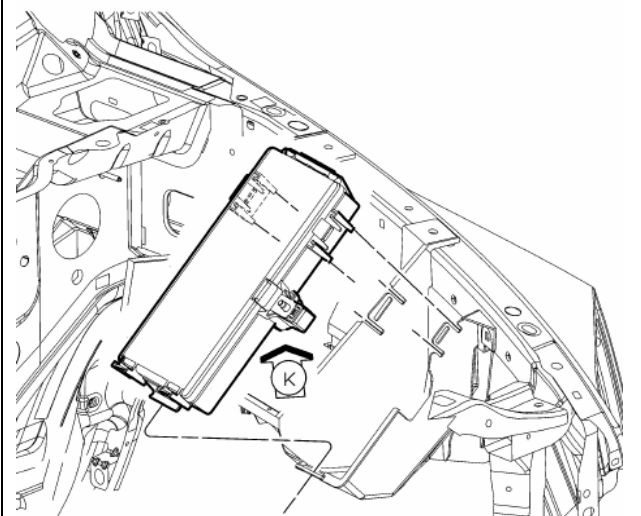
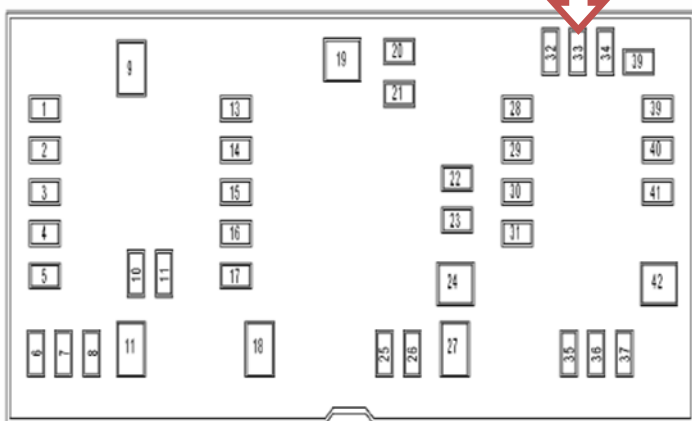

Fuse # 33 (10Amp)

ut OVER SPEED ELECTRONICS

10. Double check all wiring connections and ensure wires are routed away from any heat sources and moving parts. Then install the loom with the supplied tee connector and clips for the loom ends and continue to the testing flow chart without over speed electronics in this manual.

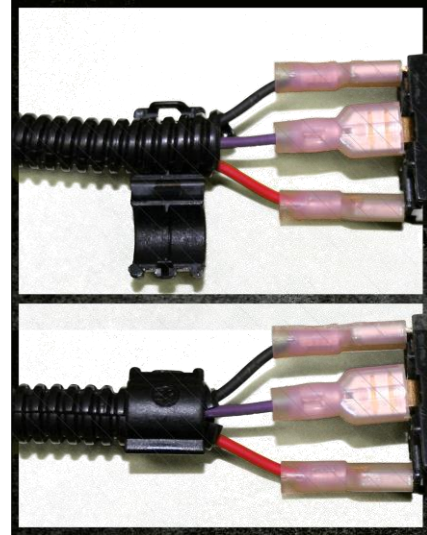
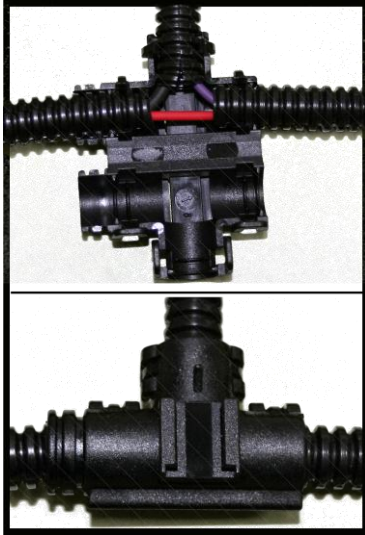

WIRING DIAGRAM with OVER SPEED ELECTRONICS (1036723)

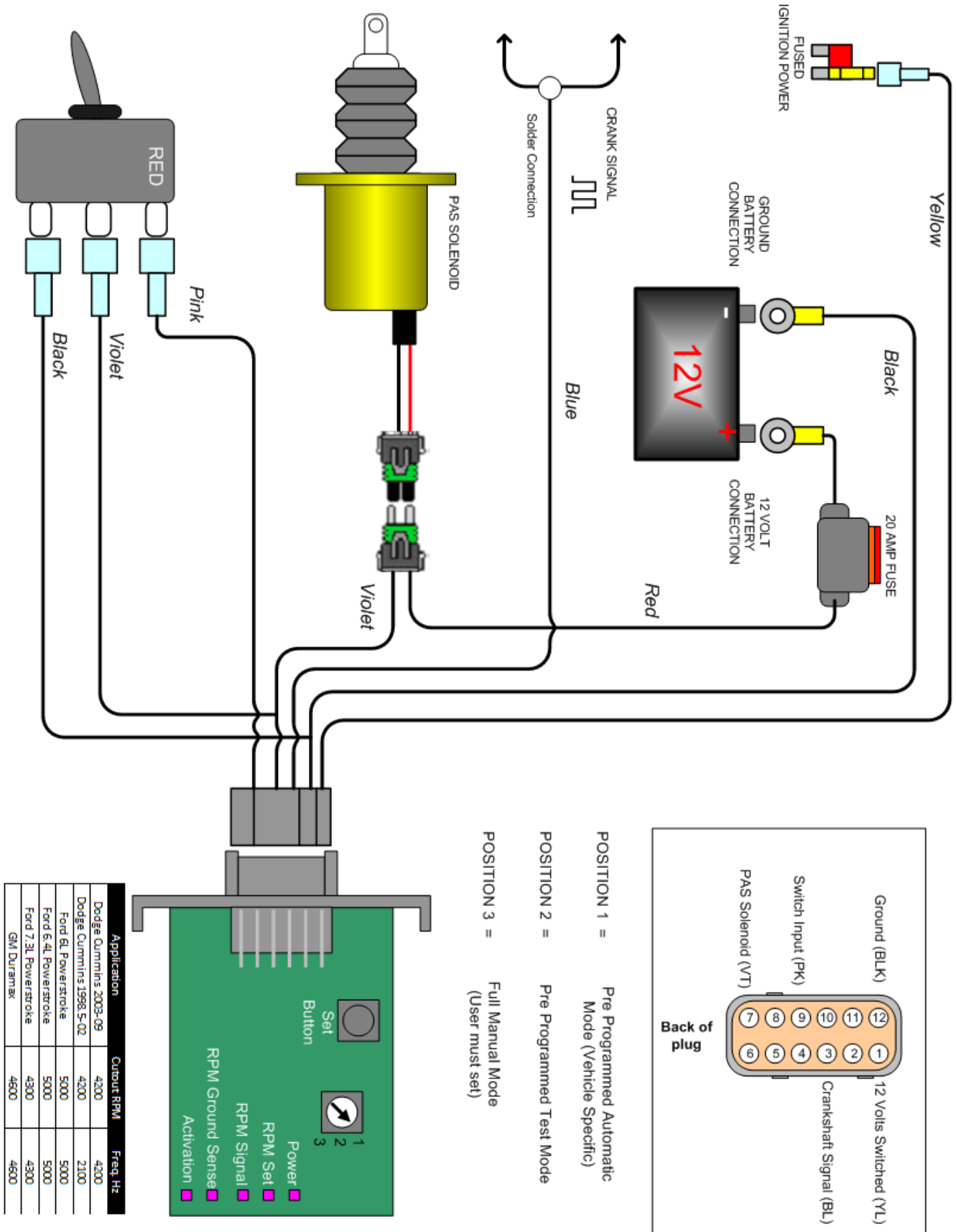

WIRING DIAGRAM without OVER SPEED ELECTRONICS (1036723-M)

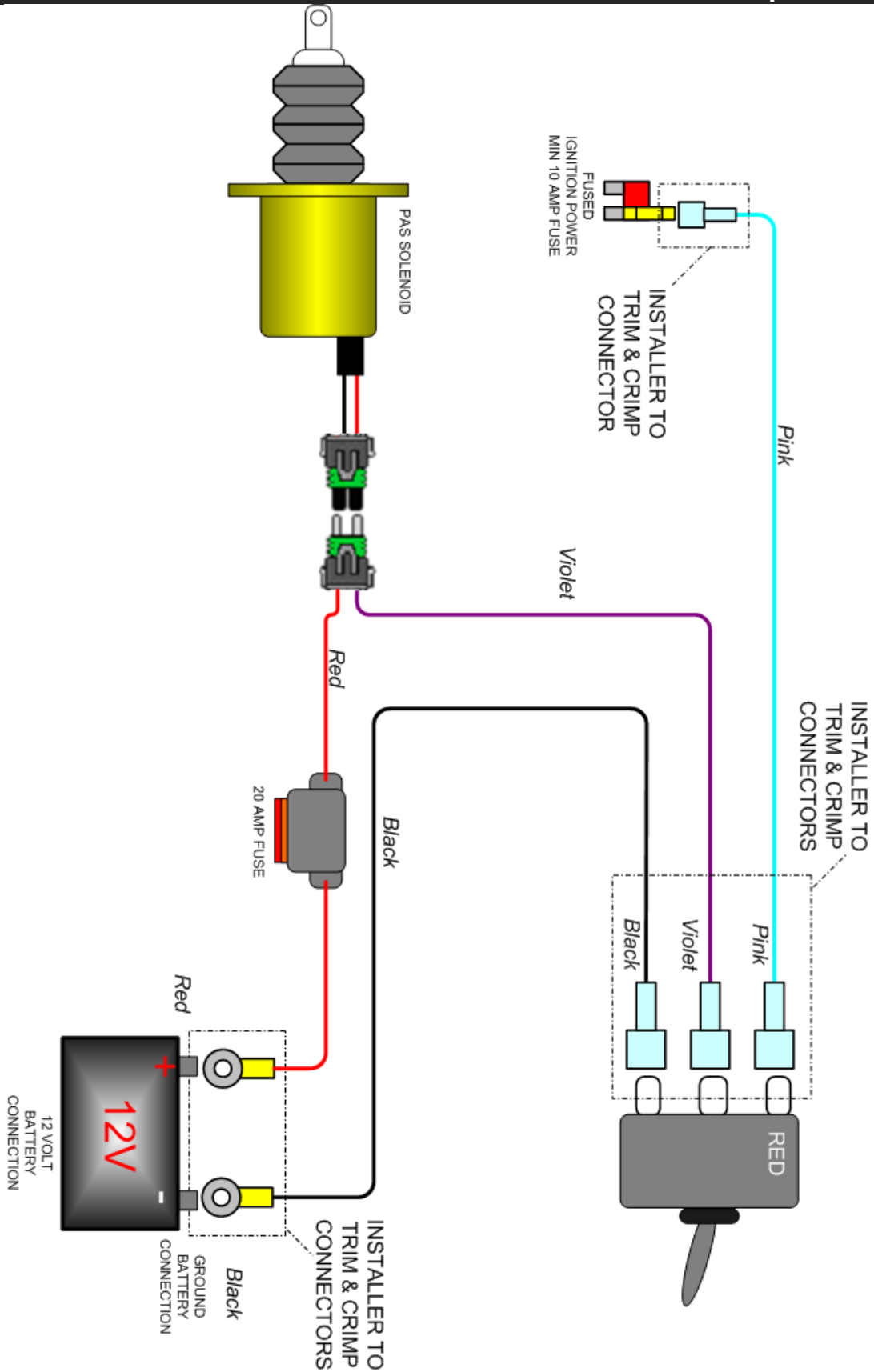

RESETTING THE VALVE

Valve Activated (Closed)

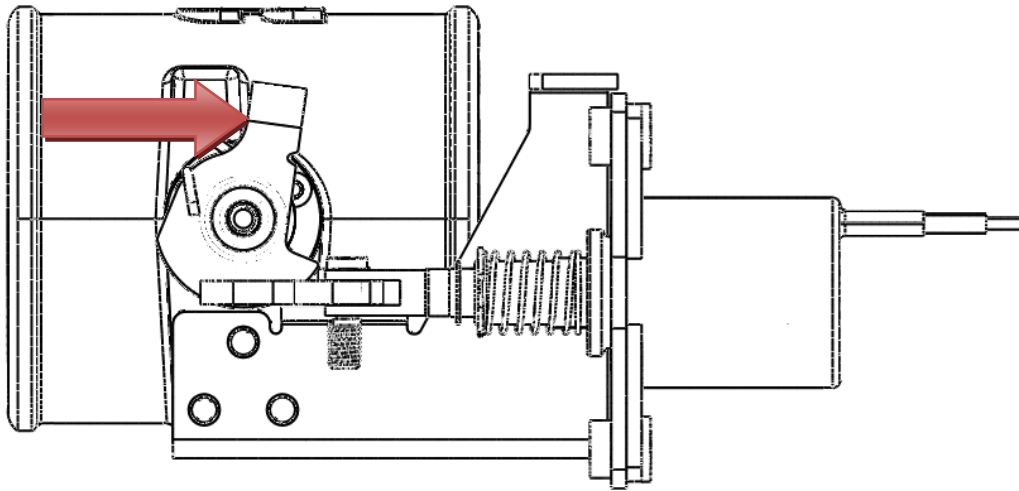

Valve Reset (Open)

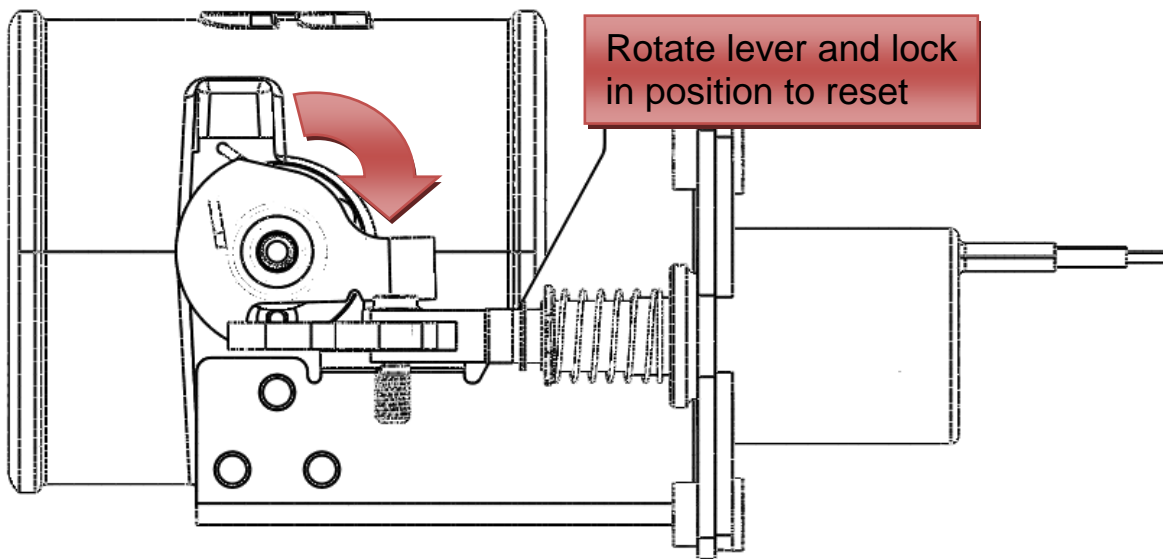

SETUP, TESTING AND VERIFICATION with OVER SPEED ELECTRONICS

Each unit is specifically configured for each model of truck. As in the case of different model years and makes the engine RPM frequency is different.	Engine Idle Speed Frequency
	03-09 Dodge Cummins 600-800 Hz (1:1) ratio

2003-2009 Dodge Cummins	Activation RPM	Activation Freq. (Hz)
PAS Switch Position #1 (Automatic Mode)	4200	4200
PAS Switch Position #2 (Test Mode)	1200	1200
PAS Switch Position #3 (Manual Mode)	User Configured	User Configured

Automatic Mode (Pre Configured RPM)	
Action	Failure/Fix/Notes
1. Turn the ignition key to the on position. You should see the RED light illuminate on the toggle switch.	If the LED does not illuminate, check the wiring to the back of the switch first. Then check entire circuit.
2. Next, start the engine. 3. With the engine idling, activate the toggle switch. You should hear the solenoid activate and the valve close. The engine should die. Once the engine dies the switch should flicker ON and OFF indicating a trip condition.	If the engine does not die, check to make sure the valve actuated. If the valve did not actuate check switch and ground wiring. If valve did actuate but the engine is still running, ensure nothing has contacted the valve mechanism
4. You can now reset the valve, by rotating the upper lever and engaging the solenoid stop.	

5. With the valve reset, remove the outer enclosure from the control module. There are two locking tabs on the sides of the enclosure.

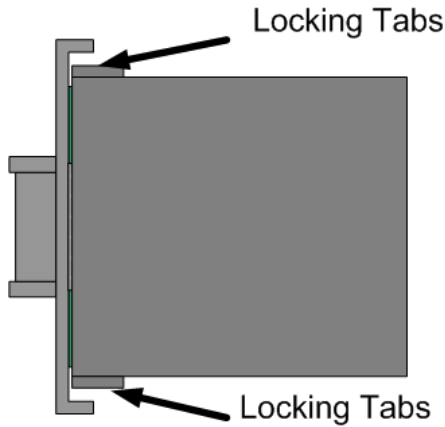

6. Change the position selection switch to position #2 (Auto Test). Slide enclosure cover over circuit board.

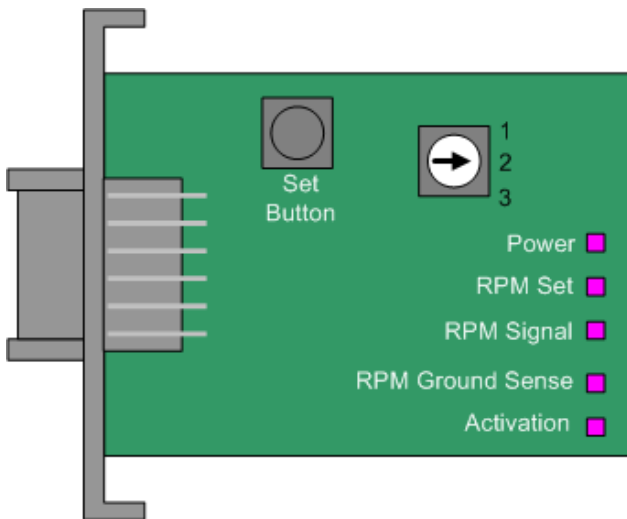

7. Start the vehicle, with the vehicle in park step on the throttle increasing the engine RPM. At 1200RPM the PAS should engage itself automatically, and the engine should stall. Like with all activations the

If the engine did not stall, check to make sure the valve actuated. If the valve did not actuated, double check the engine RPM electrical connection. Check the RPM Signal LED on the circuit

toggle switch should flash.	board, it should flash proportionally to the engine RPM.
<p>8. Reset the valve and reset the mode position switch to position #1</p>	
<p>You are now complete and the unit should function correctly. This test cycle should be completed once a year.</p>	

Manual Mode (User Configured RPM)

Setup

With the control unit, the user/installer has the ability to set their own activation RPM. It is necessary that you chose a low activation RPM first to test the units is operating correctly. Once it has, you will need to set the high limit RPM activation.

Note: When you press the Set button the module will add 25% to the set speed.

1. Open electronic enclosure, by releasing the two locking tabs on the side of the unit.

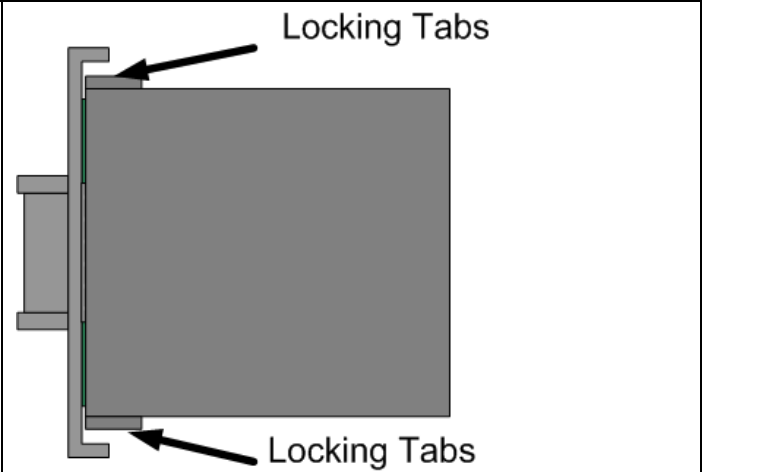

2. Adjust the position switch to Position #3.

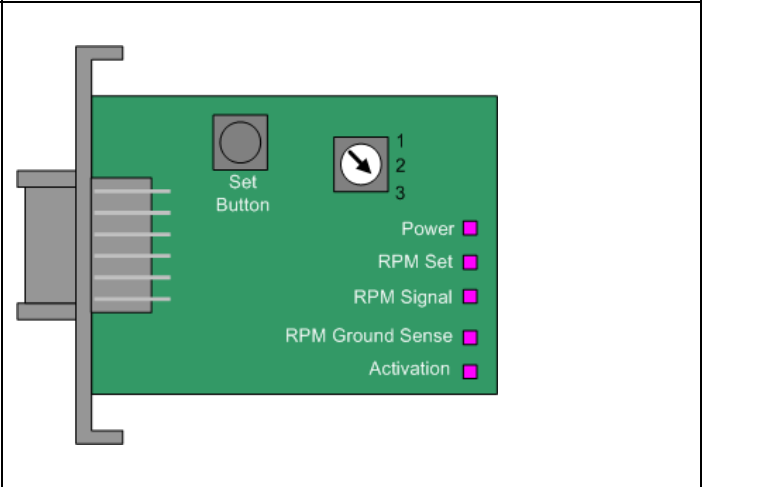
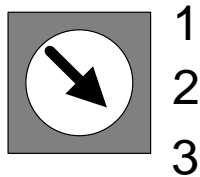

3. Start the engine.

4. Press and hold the RPM SET button.

When you push the SET RPM button will see the "RPM Set" LED illuminate.

5. With another person helping you, have them step on the accelerator with the vehicle in park. Raise the engine RPM to 1200 RPM.

6. Release the SET RPM button.

Upon releasing the button the unit will store the $RPM + 25\%$. So for this example the unit has stored $1200RPM + 25\% = 1500RPM$.

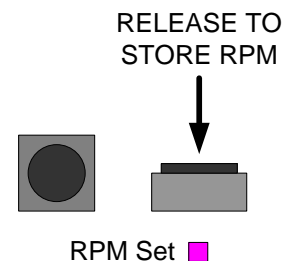
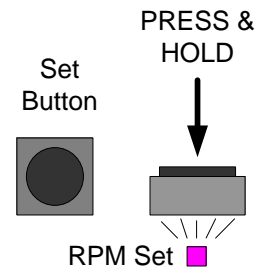

You should see the RPM signal flash proportionally to engine RPM.

7. Now increase the RPM of the engine to test the activation circuit is working correctly. As in this example the valve should activate at 1500RPM.

You should see the ACTIVATION LED flash ON/OFF on activation.

If the valve does not activate check the wiring.

If the valve activates but the engine does not stall, ensure nothing has contacted the valve linkage.

8. With the valve activated the engine should die. Reset the valve and restart the engine.

9. Press and hold the RPM SET button.

When you push the SET RPM button will see the "RPM Set" LED illuminate.

10. With another person helping you, have

BD Engine Brake Inc.

Plant Address: 33541 MacLure Rd. Abbotsford, BC, Canada V2S 7W2

U.S. Shipping Address: 88-446 Harrison St, Sumas, WA 98295 U.S. Mailing Address: P.O. Box 231, Sumas, WA 98295

Phone: 604-853-6096 | Fax: 604-853-8749 | Internet: www.bd-power.com

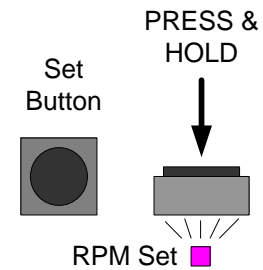
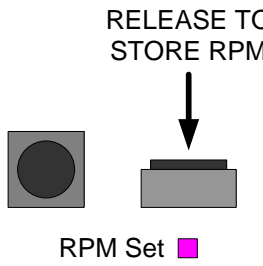
<p>them step on the accelerator with the vehicle in park. Raise the engine RPM to MAXIMUM engine RPM.</p> <p>11. Release the SET RPM button.</p> <p>Upon releasing the button the unit will store the RPM + 25%. So for this example the unit has stored MAXIMUM engine RPM + 25%.</p>	 
<p>12. You can now put the electronic enclosure back together and secure it the fuse box.</p>	
<p>13. With the engine running you will need to test to make sure the manual activation switch is functioning correctly.</p> <p>14. With the engine running, lift the activation switch and the engine should die.</p> <p>15. Reset the valve and you are now complete.</p>	<p>If valve does not activate check the wiring.</p> <p>If the valve activates and the engine does not die ensure nothing has contacted the linkage.</p>
<p>You are now complete the installation, please be sure to complete the test once a year to make sure the unit is functioning correctly.</p>	

TESTING FLOW CHART with OVER SPEED ELECTRONICS

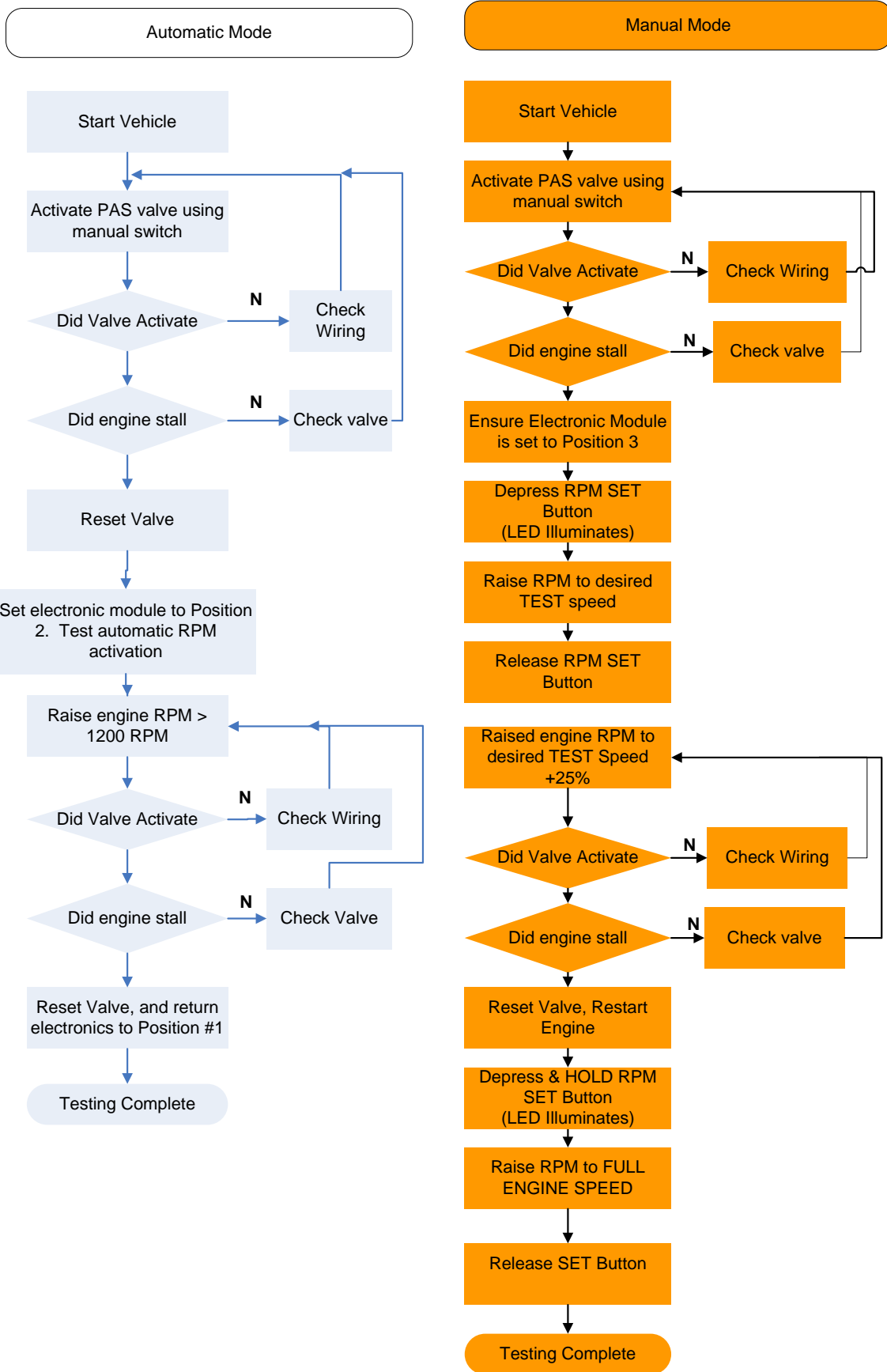

BD Engine Brake Inc.

Plant Address: 33541 MacLure Rd. Abbotsford, BC, Canada V2S 7W2

U.S. Shipping Address: 88-446 Harrison St, Sumas, WA 98295 U.S. Mailing Address: P.O. Box 231, Sumas, WA 98295

Phone: 604-853-6096 | Fax: 604-853-8749 | Internet: www.bd-power.com

TESTING FLOW CHART without OVER SPEED ELECTRONICS

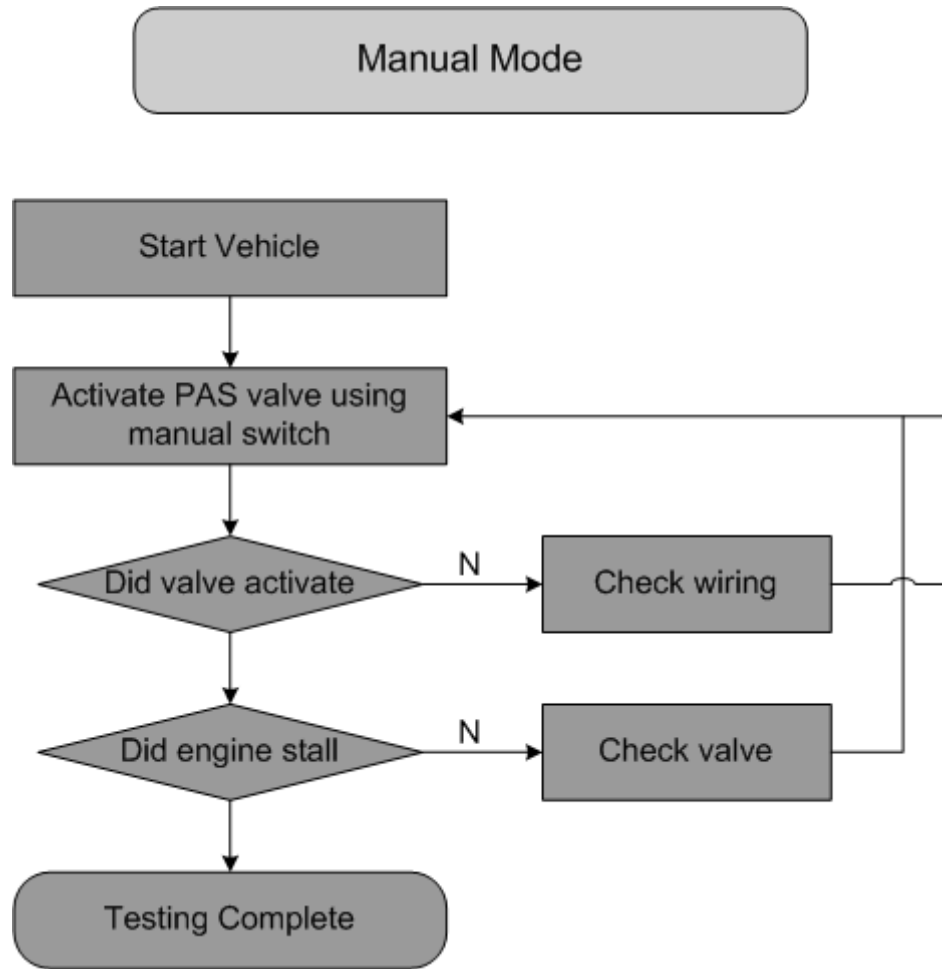

LED OPERATION

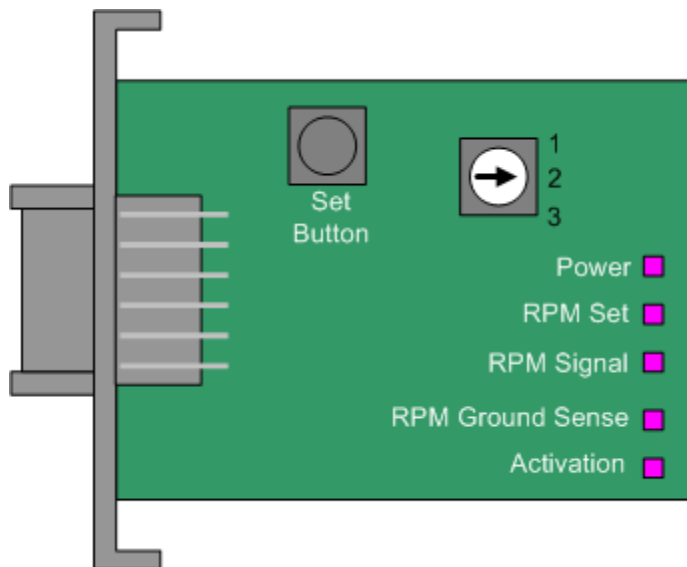

LED	Description
POWER	Illuminates when unit is POWERED
RPM SET	Illuminates when SET Button is Pressed
RPM Signal	Flashes proportional to Engine RPM
Ground Sense	Illuminates when a GROUND signal is sensed on the activation line
Activation	Flashes when a valve activation is command manually (switch) or automatically
Toggle Switch LED	The LED will flash indicating either a problem with the system (Loss of RPM or Power) or an activate valve activation.



Visit our Internet forums at <http://www.dieselpower.com> and share your comments or technical support questions with some of the industry's leading experts in the diesel field.

If you have any technical difficulties, concerns, comments, or complaints, please phone our Technical Support hotline at (800) 887-5030 between 8:30am-5:00pm PST (Pacific Standard Time) Monday to Friday, or post a message on the BD Discussion Forums located at:

<http://forum.bd-power.com/>