



1994-2002 DODGE CUMMINS **2 Low Unloc Differential Kit**

Part# 1030703

OWNER'S MANUAL – LEAVE IN GLOVE BOX
Installation Manual Part # I1030703

Please read entire instruction manual before installation.

Kit Contents



Harness w/ 2 Position Switch



Spool Valve



Black Posi-Tap



Vent Hose



Phillips Screws (x2)



3/16" Barb Splicer (x2)



Resistor – (1/4" Watt – 100 Ohm)



Vacuum Hoses – (2 x 12") , (1 x 18")

Welcome

Thank you for purchasing the BD 2 Low Unloc Differential Kit. This kit is designed to allow the operator to manually disable the front wheel drive mechanism by holding the hubs in the free (2WD) mode with the transfer case in 4WD low range. By allowing the front wheels to be disengaged, maximum torque is available to the rear wheels. This will also allow for sharp “All The Way Over” turns without the front axle u-joint hopping or binding.

With this kit installed, the front wheels will NOT be driven through the transfer case. This allows the operator to have full power and torque while in a high gear reduction applied to the rear axle(s) only.

CAUTION: This setup is to be used ONLY in areas where close, tight turns are required without the steering wheel “HOP” normally associated with 4WD operation.

Tools Required

- Phillips Screwdriver
- Electrical Pliers
- Drill and 15/32” bit (Or Unibit)
- Knife

BD Engine Brake Inc.

Plant Address: 33541 MacLure Rd. Abbotsford, BC, Canada V2S 7W2

U.S. Shipping Address: 88-446 Harrison St, Sumas, WA 98295 U.S. Mailing Address: P.O. Box 231, Sumas, WA 98295

Phone: 604-853-6096 | Fax: 604-853-8749 | Internet: www.bd-power.com

Kit Installation

Mount the 2-Low spool valve bracket onto any free bolt of the Air Inlet Horn.

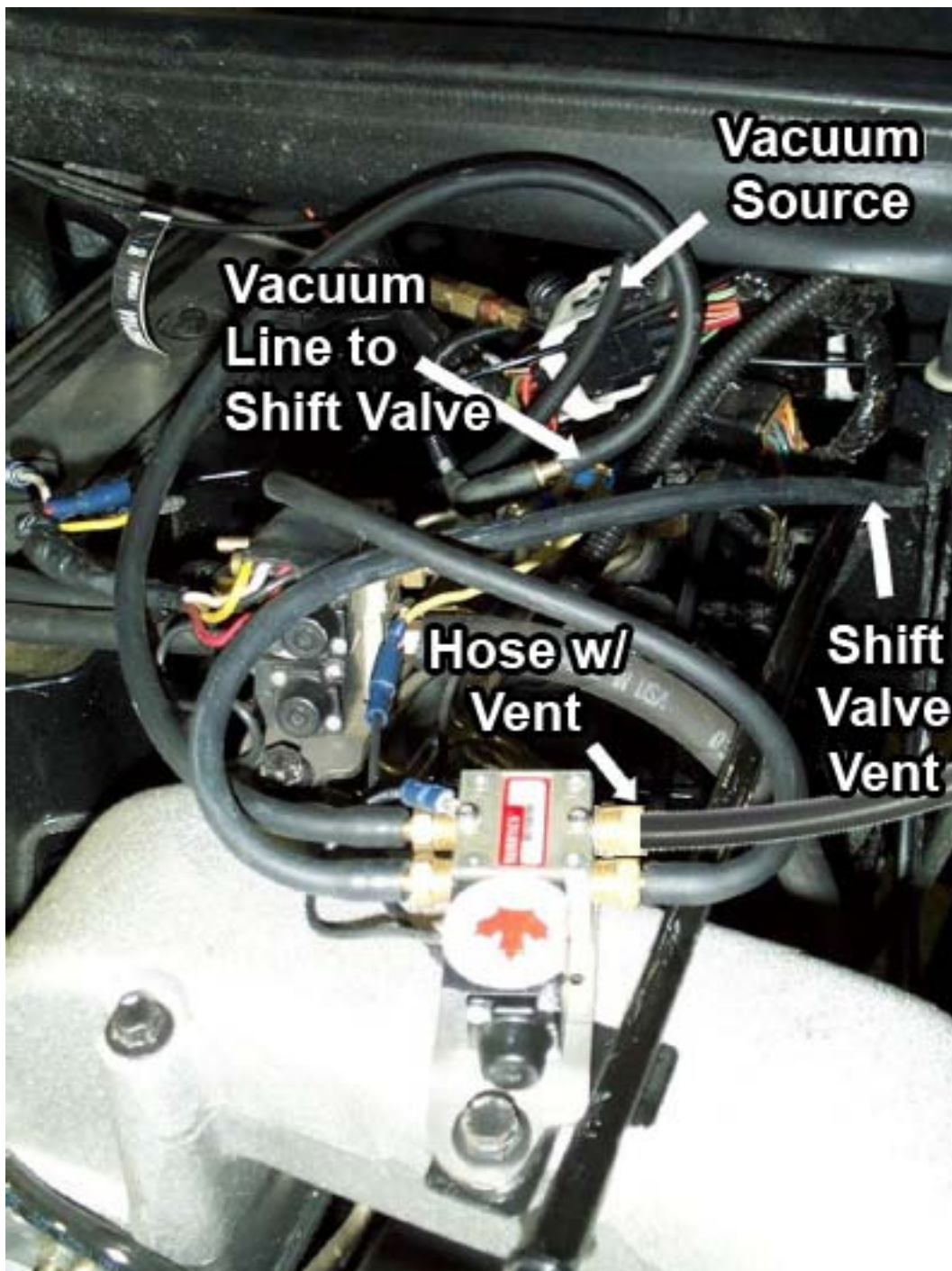

Locate the vacuum source for the front wheel lock actuator where it tees into the main vacuum hose. This is located approximately 10-12" straight behind the intake plenum under the weather stripping of the firewall.

BD Engine Brake Inc.

Plant Address: 33541 MacLure Rd. Abbotsford, BC, Canada V2S 7W2

U.S. Shipping Address: 88-446 Harrison St, Sumas, WA 98295 U.S. Mailing Address: P.O. Box 231, Sumas, WA 98295

Phone: 604-853-6096 | Fax: 604-853-8749 | Internet: www.bd-power.com

HOSE 1: Disconnect the vacuum hose from the source T-fitting located at the center of the firewall. Using one of the short hoses supplied, connect one end onto the male end of the source T-fitting at the firewall and then the other end onto the barb fitting of the control valve marked with a “1”.

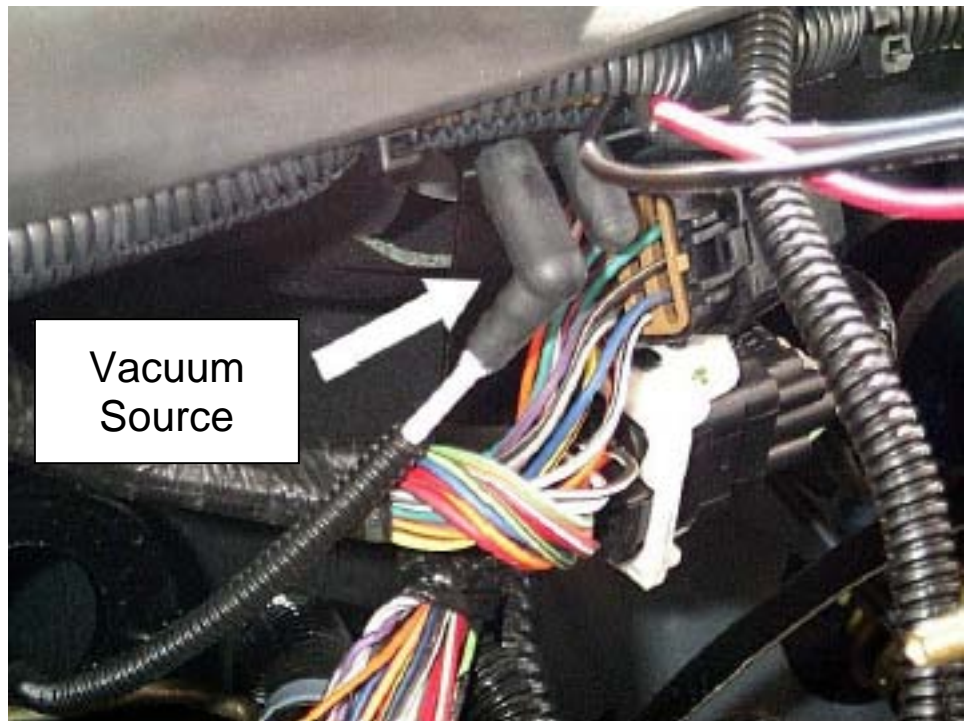

HOSE 2: Using the other short hose supplied, install one end of the barb fitting of the control valve identified with a “2”. Install one of the supplied straight splicer barbs into the other end of this hose and attach it to the vacuum source line removed from the firewall fitting.

HOSE 3: From just behind the rear engine lift eye, locate and remove the vacuum hose vent valve from the vent line of the transfer case hub control switch and install one of the straight barb fittings. Using the longer piece of hose supplied, install one end onto the fitting of the control valve marked with a “4”. Install the other end onto the barb fitting that was installed in the vent hose.

HOSE 4: Install the length of hose that has the brass filter fitted in one end onto the control valve fitting marked with a “3” and secure the filter end up under the hood weather stripping or run into the cab (sheltered from elements to prevent water and dirt from entering the valve).

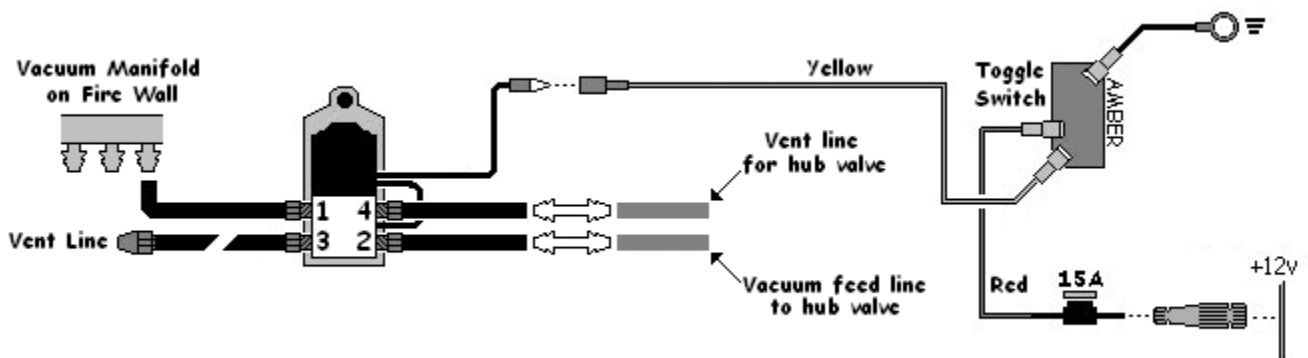

Locate a suitable spot of your choice in the cab for the toggle switch and drill a hole. Insert the switch and secure with the plastic nut.



Run the purple (or yellow) wire through the firewall and plug into the connector on the spool valve. Fasten the black wire to a good ground under the dash.

Install the Posi-Tap connector onto a switched 12-volt power source.

Ensure the 15amp fuse is installed and plugged into the connector.

Operation

To test the function of the 2 Low Kit, start the vehicle and shift the transfer case into the 4-Low range and start moving. The "4WD" dash indicator should come on. Steering all the way over, operate the truck and you should feel the steering hop as the front axle driveline is engaged and has torque applied to it (this is normal).

Stop the truck and with the front wheels relatively straight, turn the 2-Low switch to the ON position. The light on the switch should now be on, indicating operation. Wait approximately 3 seconds for the vacuum to build up and then start to move - the "4WD" indicator on the dash should come off indicating 2WD operation. If you now move with the steering all the way over you should have no steering hop as the front drive axles are prevented from engaging.

****NOTE**:** This setup redirects the front axle vacuum source and vent lines. If the switch is left in the ON position when the transfer case is in 2WD, the front axle lock will stay engaged but no drive will be transferred from the transfer case as the lever is in 2WD position which could cause undue wear on the front axles.