

BD VALVE BODY

For 2004.5-2007 Dodge 5.9L 24V Cummins Trucks
-- Installation Instructions --

	1030423	2004.5-07 Dodge 24V	48RE
--	----------------	---------------------	------

IMPORTANT – READ ALL INSTRUCTIONS BEFORE INSTALLATION.

BD Engine Brake Inc.

Plant Address: 33541 MacLure Rd. Abbotsford, BC, Canada V2S 7W2

U.S. Shipping Address: 88-446 Harrison St, Sumas, WA 98295 U.S. Mailing Address: P.O. Box 231, Sumas, WA 98295

Phone: 604-853-6096 | Fax: 604-853-8749 | Internet: www.bd-power.com

Tools Required

- Inch Pound Torque Wrench
- 7/16", 1/2" & 1 5/16" Socket
- #25 Torx Bit
- Combination Wrench Set including 7/16" & 3/4"
- High Quality Pressure Gauge (0 - 300 psi)
- Voltmeter
- 6" C Clamp

Additional Parts Required (Not Included)

- Mopar ATF+4
- 1 Bottle of Red Lubeguard (Recommended)

All Diesel Rams should be tested prior to engine or transmission performance tuning. Check transmission oil level prior to all work. Pressure testing will produce test results that can help to determine the ability of the transmission to prevent the clutch surfaces from slipping. Slippage will result in premature convertor and transmission wearing characteristics (soft or severe shifting, high transmission temperature).

NOTE – Transmission needs to be at operating temperature.

48RE Transmissions

Transmission Line Pressure	OEM Pressure	BD Pressure	Test #1	Test #2
Transmission in DRIVE w/Engine at idle	55-65psi	90-110psi		
Transmission in DRIVE w/Convertor Locked up @ WOT	110-120psi	170-200psi		

Transmission Shift Points

Transmission Shift Point (RPM)	Before	After
2 nd – 3 rd Shift point (Normal Driving)		
2 nd – 3 rd Shift point (Wide Open Throttle)		

IMPORTANT – IF PRESSURES AND/OR SHIFT POINTS ARE NOT TO SPEC, THE TRANSMISSION MUST BE REPAIRED OR SERVICED BEFORE MODIFICATIONS.

BD Engine Brake Inc.

Plant Address: 33541 MacLure Rd. Abbotsford, BC, Canada V2S 7W2

U.S. Shipping Address: 88-446 Harrison St, Sumas, WA 98295 U.S. Mailing Address: P.O. Box 231, Sumas, WA 98295

Phone: 604-853-6096 | Fax: 604-853-8749 | Internet: www.bd-power.com

Installation

1. Pressure testing is accomplished by inserting a fitting and hose assembly with a good quality gauge into the center 1/8" port on the passenger side of the transmission. Leave the gauge attached for testing later.
2. **VERY IMPORTANT** – Road test with gauge in place and record pressures and shift point RPM's **BEFORE** modifications are carried out to determine the condition of the transmission prior to installing this valve body. **Pressure will only be indicated with transmission in Drive position.**
3. Secure the vehicle with wheel chocks and place the transmission in Neutral.
4. Ensure the valve body has not been damaged in shipping and it is the proper part number for your vehicle.
5. Starting at the transmission, remove the shift cable from the manual lever.
6. Rotate the shift lever to the rear of the vehicle to place the transmission in the PARK position.



BD Engine Brake Inc.

Plant Address: 33541 MacLure Rd. Abbotsford, BC, Canada V2S 7W2

U.S. Shipping Address: 88-446 Harrison St, Sumas, WA 98295 U.S. Mailing Address: P.O. Box 231, Sumas, WA 98295

Phone: 604-853-6096 | Fax: 604-853-8749 | Internet: www.bd-power.com

7. Remove the two (2) bolts holding the TTVA motor to the transmission case.
8. Allow the TTVA to rotate clockwise away from the transmission.

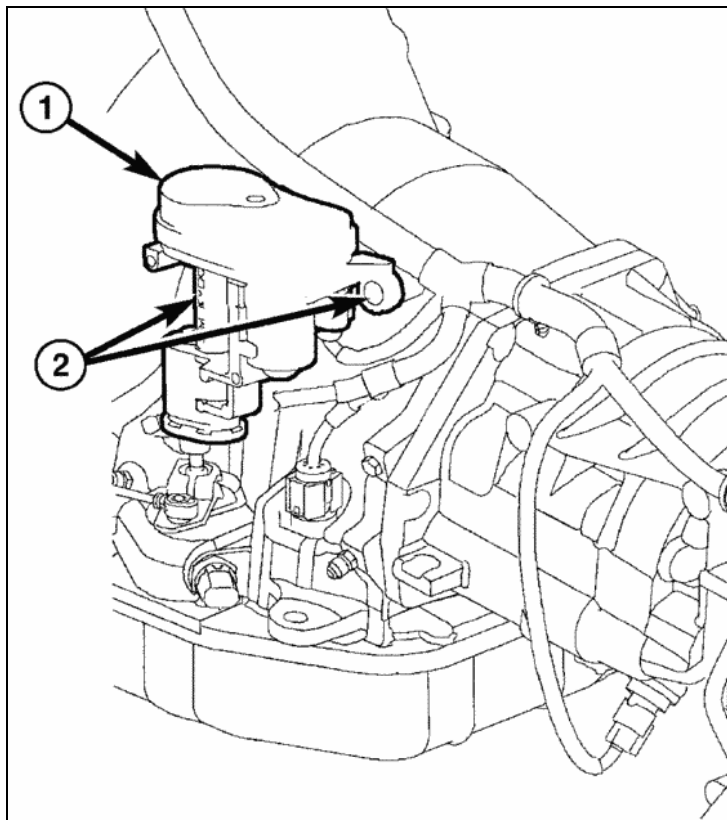

9. Remove the wiring connector (#2) from the TTVA.
10. Lift the TTVA straight upward and off of the throttle valve shaft.

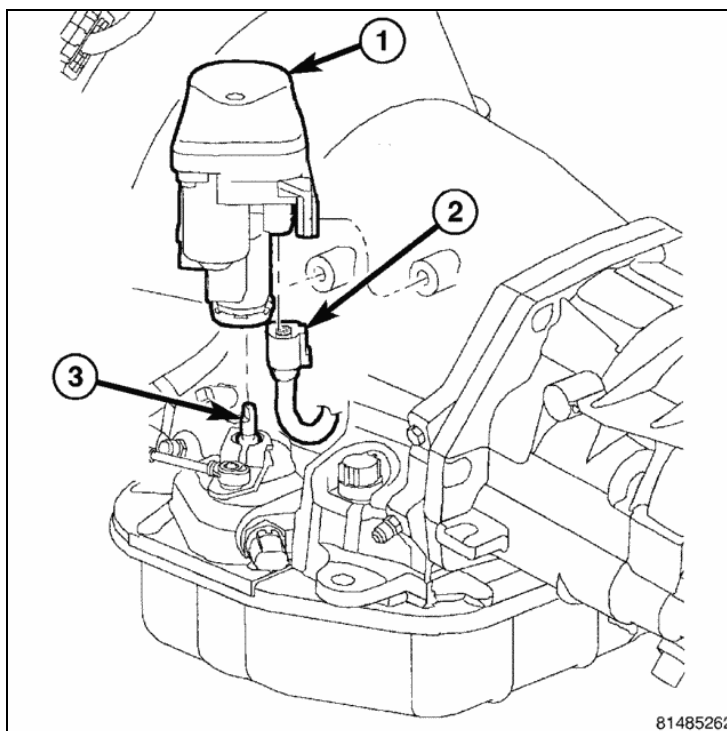

BD Engine Brake Inc.

Plant Address: 33541 MacLure Rd. Abbotsford, BC, Canada V2S 7W2

U.S. Shipping Address: 88-446 Harrison St, Sumas, WA 98295 U.S. Mailing Address: P.O. Box 231, Sumas, WA 98295

Phone: 604-853-6096 | Fax: 604-853-8749 | Internet: www.bd-power.com

11. Loosen the shift lever bolt, and then rotate the lever towards the front of the truck shifting the transmission into 1st / LOW position. This allows for the removal of the Park Rod E-clip without dropping the valve body.

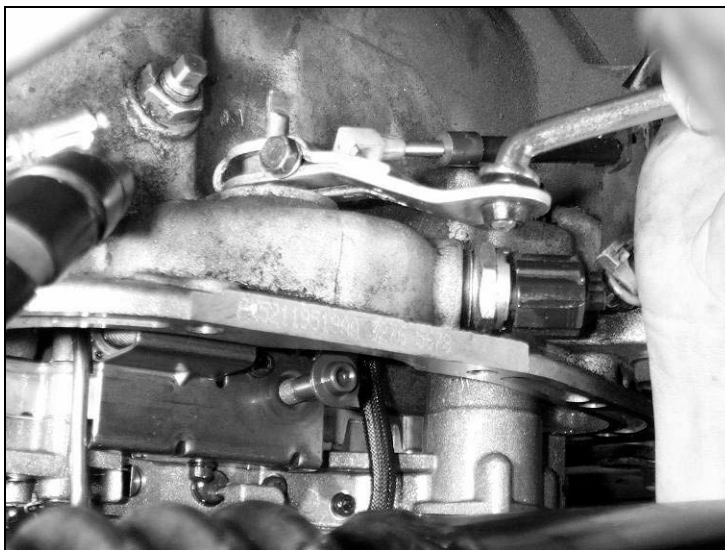

12. Remove the shift lever.

13. Disconnect the wiring connectors from the Neutral Safety switch and Valve Body then remove the Neutral Safety switch from the transmission.

14. Place a large drain pan under transmission, remove the oil pan, drain the transmission oil and then remove the filter.

15. Carefully remove the E-clip from the park rod, leaving the park rod in the transmission.

16. Remove the 10 valve body bolts, remembering the location of the different bolts. **Attaching bolts are different lengths and MUST be reinstalled in the proper location.**

17. When lowering the valve body, gently work it around so that the park rod lever is left in the transmission and ensure the electrical plug is not damaged in the removal process.

18. **CAUTION** - As you lower the valve body, watch for the accumulator piston and spring falling out. They are located above the gov. solenoid



BD Engine Brake Inc.

Plant Address: 33541 MacLure Rd. Abbotsford, BC, Canada V2S 7W2

U.S. Shipping Address: 88-446 Harrison St, Sumas, WA 98295 U.S. Mailing Address: P.O. Box 231, Sumas, WA 98295

Phone: 604-853-6096 | Fax: 604-853-8749 | Internet: www.bd-power.com

19. This is the time to change the 2nd gear band strut to the heavy duty one and install the 2nd gear servo spring we supply. First loosen the band adjusting screw lock nut with a 3/4" wrench, and then unscrew adjuster until the stock strut can be removed.



Stock Band Strut in Place



New BD Band Strut In Place

20. For the next step of the instructions you will need a 6" C Clamp. This 6" C clamp is available from Autozone (#QRCC6) or from Schucks / O'Reilly's (#648641).

The cost on this part is roughly \$10.



21. Using a 6" 'C' Clamp and a 1 5/16" socket (or 32mm), depress servo piston guide into bore of the transmission. *This is a critical step and damage could ruin the transmission.*

DO NOT LET ANYTHING SCORE THE BORE OR THE SHAFT.

BD Engine Brake Inc.

Plant Address: 33541 MacLure Rd. Abbotsford, BC, Canada V2S 7W2

U.S. Shipping Address: 88-446 Harrison St, Sumas, WA 98295 U.S. Mailing Address: P.O. Box 231, Sumas, WA 98295

Phone: 604-853-6096 | Fax: 604-853-8749 | Internet: www.bd-power.com



22. Remove retaining clip. DO NOT LOSE.
23. Loosen C clamp to allow servo piston guide to be removed from bore. Remove clamp, servo piston guide and spring.



24. Add newly supplied spring to back of servo piston guide, along with the original.

BD Engine Brake Inc.

Plant Address: 33541 MacLure Rd. Abbotsford, BC, Canada V2S 7W2

U.S. Shipping Address: 88-446 Harrison St, Sumas, WA 98295 U.S. Mailing Address: P.O. Box 231, Sumas, WA 98295

Phone: 604-853-6096 | Fax: 604-853-8749 | Internet: www.bd-power.com

25. Re-install servo piston guide into bore with both springs. Hold the servo piston guide in place while slowly tightening the C clamp.

Tighten C clamp very slowly up until the servo piston guide ring touches the bore taper.

Help servo piston guide ring into bore with a small blunt screw driver. **DO NOT DAMAGE SERVO PISTON GUIDE RING.**

If servo piston guide ring binds or catches retaining ring groove lightly tap the servo piston guide to release it.



26. Once servo piston guide is depressed far enough you then can install the retaining ring. Once installed you can remove the C clamp.

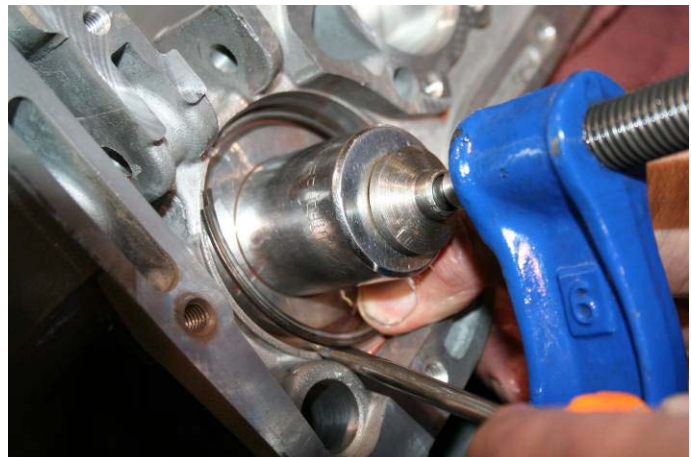

27. Install the new BD strut with tapered side down, towards the pan, and centered in the guides. Torque the band adjustment to 72 inch-lbs, then back it out 2 1/4 turns and then tighten the lock nut. The measurement for the air gap between the band lever and servo piston is 5/16".

BD Engine Brake Inc.

Plant Address: 33541 MacLure Rd. Abbotsford, BC, Canada V2S 7W2

U.S. Shipping Address: 88-446 Harrison St, Sumas, WA 98295 U.S. Mailing Address: P.O. Box 231, Sumas, WA 98295

Phone: 604-853-6096 | Fax: 604-853-8749 | Internet: www.bd-power.com

- 28.** From the old valve body, remove the electrical solenoid and sensor, and then install them on the new BD Valve Body. **We recommend new gov. solenoid & pressure transducer be installed.**

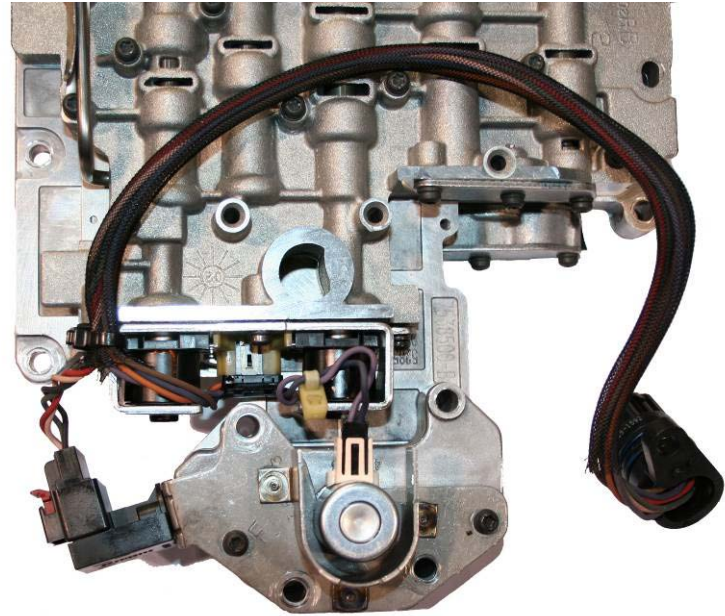

BD Engine Brake Inc.

Plant Address: 33541 MacLure Rd. Abbotsford, BC, Canada V2S 7W2

U.S. Shipping Address: 88-446 Harrison St, Sumas, WA 98295 U.S. Mailing Address: P.O. Box 231, Sumas, WA 98295

Phone: 604-853-6096 | Fax: 604-853-8749 | Internet: www.bd-power.com

VERY IMPORTANT

A modification needs to be made to the pressure transducer switch (the black plastic style switch) for the 2000-2007 model year trucks, before it is installed on the valve body.

To prevent over pressure damage to the transducer, it will need to have a .040 orifice cup plug installed as shown in the illustration. The best method to insert the orifice cup plug is to squeeze it in gently with a vice. (DO NOT USE A HAMMER).

Once installed the orifice cup plug should be flush.

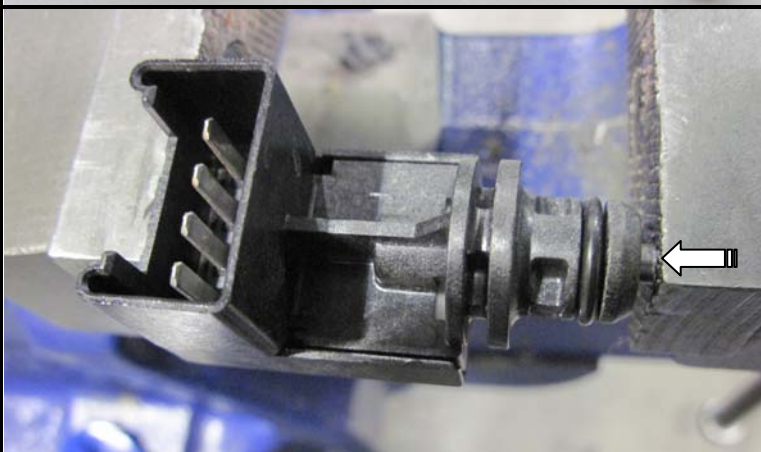
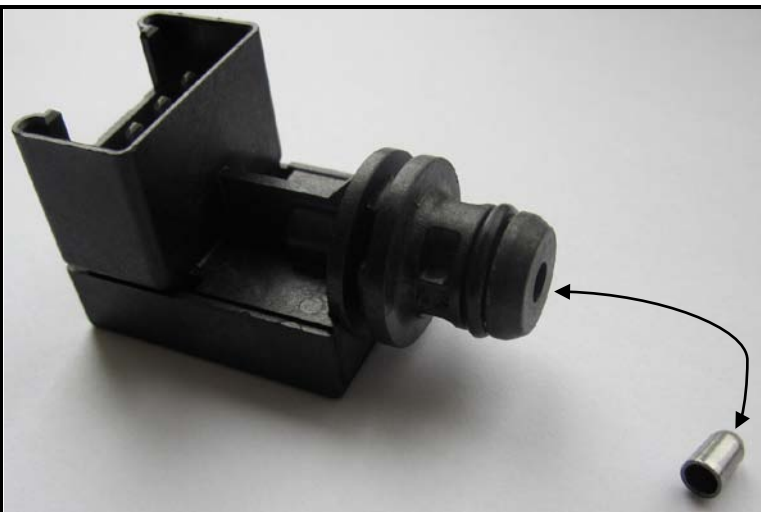

BD Engine Brake Inc.

Plant Address: 33541 MacLure Rd. Abbotsford, BC, Canada V2S 7W2

U.S. Shipping Address: 88-446 Harrison St, Sumas, WA 98295 U.S. Mailing Address: P.O. Box 231, Sumas, WA 98295

Phone: 604-853-6096 | Fax: 604-853-8749 | Internet: www.bd-power.com

29. **IMPORTANT** - Before installing the BD valve body, lubricate the manual-shifting shaft and the O-ring on the electrical connector that fit into the transmission case. Rotate the shift lever all the way forward to place the valve body in the 1st / Low gear position for later attaching of the park rod and E-clip.

30. Place the accumulator piston and spring in the BD valve body, if you cannot balance these parts on the valve body, hold them in place with a supporting tool or wire until the valve body is installed.

31. Once the valve body is in position, insert the Park rod into the Manual shift lever and hold the valve body in place with a couple of bolts.



32. Install the E-clip on the park rod using the flat, slotted end of the Canadian micro-hockey stick.



“Hockey Stick” Tool

BD Engine Brake Inc.

Plant Address: 33541 MacLure Rd. Abbotsford, BC, Canada V2S 7W2

U.S. Shipping Address: 88-446 Harrison St, Sumas, WA 98295 U.S. Mailing Address: P.O. Box 231, Sumas, WA 98295

Phone: 604-853-6096 | Fax: 604-853-8749 | Internet: www.bd-power.com

33. Install the valve body mounting bolts, ensuring the different length bolts are installed in the proper positions, and torque evenly to 10 ft-lbs.
34. Install the manual lever on the outside of the transmission and check for full movement of the detent shift. There must be 5 distinct positions that are felt from Low to Park. Leave in the Neutral position and tighten the retaining bolt.

35. It is now time to re-install the TTVA motor onto the throttle valve shaft.

- a) Position the transmission throttle valve actuator (TTVA) over the throttle valve shaft (#3).
- b) Align the D-shaped opening in the bottom of the TTVA to the throttle valve shaft and install the TTVA onto the shaft.
- c) Install the wiring connector (#2) to the TTVA (#1).

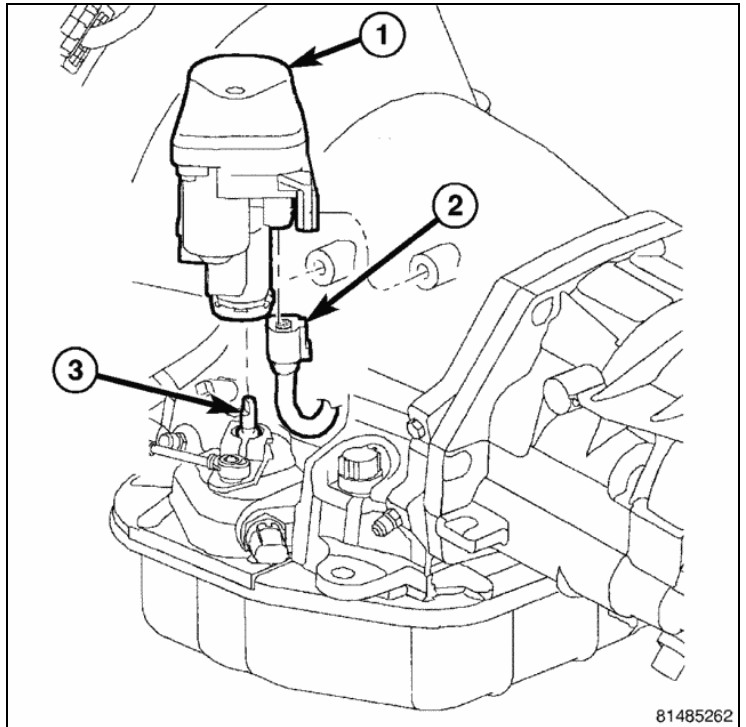

BD Engine Brake Inc.

Plant Address: 33541 MacLure Rd. Abbotsford, BC, Canada V2S 7W2

U.S. Shipping Address: 88-446 Harrison St, Sumas, WA 98295 U.S. Mailing Address: P.O. Box 231, Sumas, WA 98295

Phone: 604-853-6096 | Fax: 604-853-8749 | Internet: www.bd-power.com

- d) Rotate the TTVA (#1) to the transmission case and install the two bolts to hold the TTVA to the transmission.
- e) Tighten the bolts to **8.5 N·m (75 in.lbs.)**.
- f) Initialize the TTVA.

Initialization Procedure:

TURN KEY ON (KOE) THEN LEAVE THE KEY IN THE ON POSITION (KOE) FOR 1 FULL MINUTE.

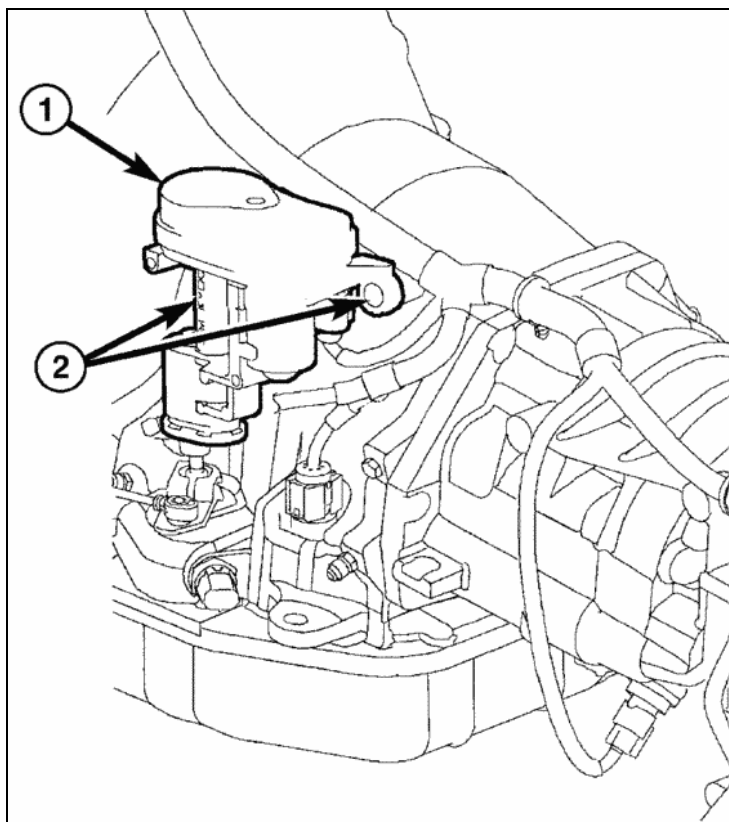

- 36. Install the neutral safety switch. The reverse lights at the back of vehicle should light when shift lever is in the reverse position (key on).
- 37. Install the new filter onto the valve body.
- 38. We suggest you install a BD HD oil pan, which has extra oil capacity, cooling fins, a magnetic drain plug, and adds strength to the transmission case to prevent flexing.
- 39. Install the shift cable to the manual lever on the transmission. Adjustment of the manual shift cable may be needed at this time. Ensure that the wiring harness has some dielectric grease on it and then connect it. Ensure not to bend the pins when attaching the plug.

BD Engine Brake Inc.

Plant Address: 33541 MacLure Rd. Abbotsford, BC, Canada V2S 7W2

U.S. Shipping Address: 88-446 Harrison St, Sumas, WA 98295 U.S. Mailing Address: P.O. Box 231, Sumas, WA 98295

Phone: 604-853-6096 | Fax: 604-853-8749 | Internet: www.bd-power.com

ADJUSTMENTS - GEARSHIFT CABLE THIS MUST BE DONE!!

Check adjustment by starting the engine in PARK and NEUTRAL. Adjustment is CORRECT if the engine starts only in these positions. Adjustment is INCORRECT if the engine starts in one but not both positions. If the engine starts in any position other than PARK or NEUTRAL, or if the engine will not start at all, the transmission range sensor may be faulty.

Gearshift Adjustment Procedure

1. Shift transmission into PARK.
2. Release cable adjuster lock tab (3) (underneath the steering column) to unlock cable.
3. Raise vehicle.
4. Disengage the cable eyelet from the transmission manual shift lever.
5. Verify transmission shift lever is in PARK detent by moving lever fully rearward. Last rearward detent is PARK position.
6. Verify positive engagement of transmission park lock by attempting to rotate propeller shaft. Shaft will not rotate when park lock is engaged.
7. Snap the cable eyelet onto the transmission manual shift lever.
8. Lower vehicle.
9. Lock shift cable by pressing cable adjuster lock tab (3) downward until it snaps into place.
10. Check engine starting. Engine should start only in PARK and NEUTRAL.

BD Engine Brake Inc.

Plant Address: 33541 MacLure Rd. Abbotsford, BC, Canada V2S 7W2

U.S. Shipping Address: 88-446 Harrison St, Sumas, WA 98295 U.S. Mailing Address: P.O. Box 231, Sumas, WA 98295

Phone: 604-853-6096 | Fax: 604-853-8749 | Internet: www.bd-power.com

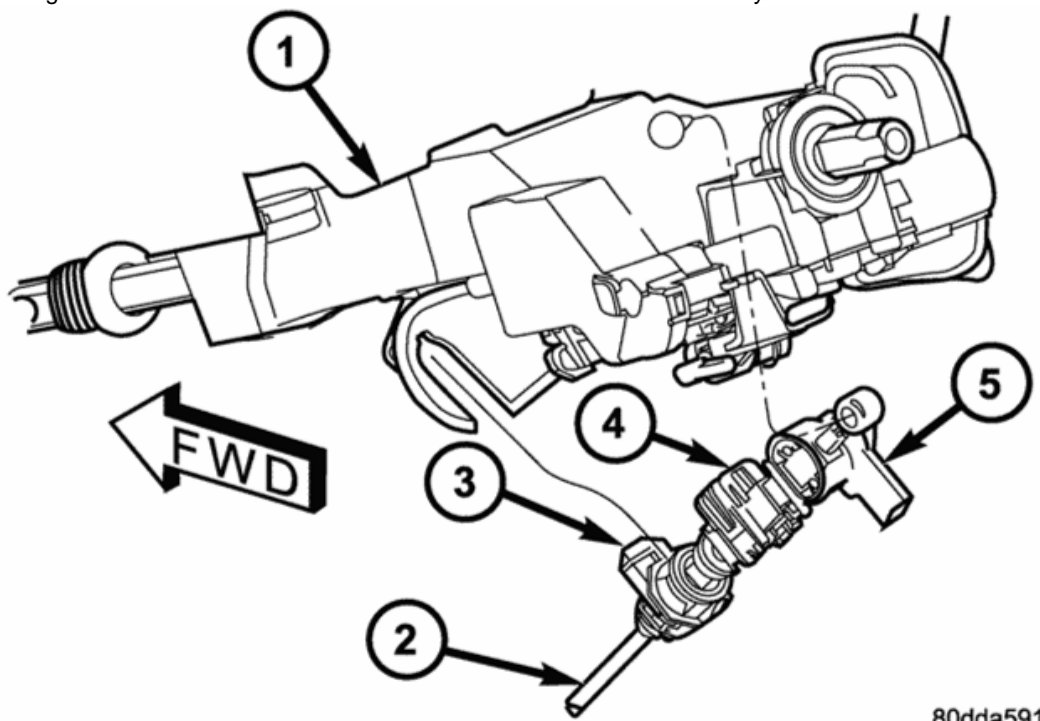

1 - STEERING COLUMN
2 - GEARSHIFT CABLE
3 - GEARSHIFT CABLE LOCK TAB
4 - BTSI SOLENOID LOCK TAB
5 - BTSI CONNECTOR

40. When just the valve body is replaced, fill the transmission with 8 - 9 quarts of ATF. When both the valve body and torque converter are replaced, 15 - 17 quarts are required. **IMPORTANT:** After 8 quarts have been added, start engine and shift through all gears, then check the transmission oil level with the shifter in neutral. Top up and check as required. **DO NOT OVERFILL!**
41. After test drive, check oil levels again. Air locks are common in this transmission.
42. Road test vehicle and check for the wide-open shift points to ensure they are correct and to verify pressures.

BD Engine Brake Inc.

Plant Address: 33541 MacLure Rd. Abbotsford, BC, Canada V2S 7W2

U.S. Shipping Address: 88-446 Harrison St, Sumas, WA 98295 U.S. Mailing Address: P.O. Box 231, Sumas, WA 98295

Phone: 604-853-6096 | Fax: 604-853-8749 | Internet: www.bd-power.com

To recalibrate the TTVA motor you will need to follow the below procedure:

TURN KEY ON, THEN LEAVE THE KEY IN THE ON POSITION (KOEO) FOR 1 FULL MINUTE.

NOTE: A RESISTOR IS NOT USED ON 2005-07 48RE VEHICLES

Questions?

If you require assistance with this kit, please call our Transmission Technical Support Line at (800) 887-5030, Monday to Friday from 8:00-4:00pm Pacific Standard Time (PST). As an alternative, you can post a support question on our technical forum, located at <http://www.bd-power.com/forum/>.



BD Engine Brake Inc.

Plant Address: 33541 MacLure Rd. Abbotsford, BC, Canada V2S 7W2

U.S. Shipping Address: 88-446 Harrison St, Sumas, WA 98295 U.S. Mailing Address: P.O. Box 231, Sumas, WA 98295

Phone: 604-853-6096 | Fax: 604-853-8749 | Internet: www.bd-power.com