

BD VALVE BODY

For 1996-2004 Dodge 5.9L 12V/24V Cummins Trucks

-- Installation Instructions --

1030416	1996-1998 Dodge 12V	47RE
1030417	1998½-1999 Dodge 24V	47RE
1030418	2000-2002 Dodge 24V	47RE
1030419	2003-2004 Dodge 24V	47RE/48RE

PLEASE READ ALL INSTRUCTIONS BEFORE INSTALLATION

BD Engine Brake Inc.

Plant Address: 33541 MacLure Rd. Abbotsford, BC, Canada V2S 7W2

U.S. Shipping Address: 88-446 Harrison St, Sumas, WA 98295 U.S. Mailing Address: P.O. Box 231, Sumas, WA 98295

Phone: 604-853-6096 | Fax: 604-853-8749 | Internet: www.bd-power.com

Tools Required

- Inch Pound Torque Wrench
- 3/8" or 1/2" drive socket sets including 7/16" & 1/2" sockets
- #25 Torx Bit
- Combination Wrench Set including 7/16" & 3/4"
- High quality pressure gauge (0-300psi)
- Voltmeter

Additional Parts Required (Not included)

- Mopar ATF+4
- 1 Bottle of Red Lube Guard (recommended)

Installation Notes

All Diesel Rams should be tested prior to engine or transmission performance tuning. Check transmission oil level prior to all work. Pressure testing will produce test results that can help to determine the ability of the transmission to prevent the clutch surfaces from slipping. Slippage will result in premature converter and transmission wearing characteristics (soft or severe shifting, high transmission temperature).

NOTE - Transmission must be at operating temperature.

47RE Transmissions

Transmission Line Pressure	OEM Pressure	BD Pressure	Test #1	Test #2
Transmission in DRIVE w/Engine at idle	55-65psi	90-110psi		
Transmission in DRIVE w/Convertor Locked up @ WOT	110-120psi	170-180psi		

48RE Transmissions

Transmission Line Pressure	OEM Pressure	BD Pressure	Test #1	Test #2
Transmission in DRIVE w/Engine at idle	55-65psi	90-110psi		
Transmission in DRIVE w/Convertor Locked up @ WOT	110-120psi	170-200psi		

BD Engine Brake Inc.

Plant Address: 33541 MacLure Rd. Abbotsford, BC, Canada V2S 7W2

U.S. Shipping Address: 88-446 Harrison St, Sumas, WA 98295 U.S. Mailing Address: P.O. Box 231, Sumas, WA 98295

Phone: 604-853-6096 | Fax: 604-853-8749 | Internet: www.bd-power.com

Transmission Shift Points

Transmission Shift Point (RPM)	Before	After
2 nd – 3 rd Shift point (Normal Driving)		
2 nd – 3 rd Shift point (Wide Open Throttle)		

IMPORTANT – IF PRESSURES AND/OR SHIFT POINTS ARE NOT TO SPECS, THE TRANSMISSION MUST BE REPAIRED OR SERVICED BEFORE MODIFICATIONS.

BD Engine Brake Inc.

Plant Address: 33541 MacLure Rd. Abbotsford, BC, Canada V2S 7W2

U.S. Shipping Address: 88-446 Harrison St, Sumas, WA 98295 U.S. Mailing Address: P.O. Box 231, Sumas, WA 98295

Phone: 604-853-6096 | Fax: 604-853-8749 | Internet: www.bd-power.com

Pressure Testing

1. Pressure testing is accomplished by inserting a fitting and hose assembly with a good quality gauge into the center 1/8" port on the passenger side of the transmission. Leave the gauge attached for testing later.
2. **VERY IMPORTANT** – Road test with the pressure gauge in place and record pressures and shift point RPM's **BEFORE** modifications are carried out to determine the condition of the transmission prior to installing this valve body. ***Pressure will only be indicated with the transmission in "Drive"***.
3. Secure the vehicle with wheel chocks and place the transmission in Neutral.
4. Ensure the valve body has not been damaged in shipping and it is the proper part number for your vehicle.
5. Starting at the transmission, remove the kick down lever and spring.



6. Rotate the shift lever to the rear of the vehicle to place the transmission in the PARK position.



7. Loosen the shift lever bolt then rotate the lever towards the front of the truck shifting the transmission into 1st / LOW position. This allows for the removal of the Park Rod E-clip without dropping the valve body. Remove shift lever.

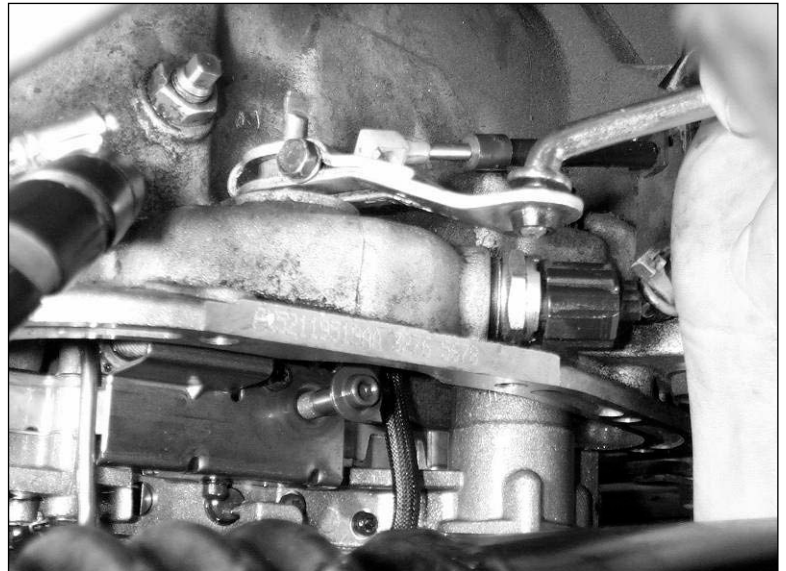

8. Disconnect the wiring connectors from the Neutral Safety switch and Valve Body then remove the Neutral Safety switch from the transmission.
9. Place a large drain pan under the transmission, remove the oil pan, drain the transmission oil and remove the filter.
10. Carefully remove the E-clip from the park rod, leaving the park rod in the transmission.
11. Remove the 10 valve body bolts, remembering the location of the different bolts.

The bolts are different lengths and MUST be re-installed in the proper location.

BD Engine Brake Inc.

Plant Address: 33541 MacLure Rd. Abbotsford, BC, Canada V2S 7W2

U.S. Shipping Address: 88-446 Harrison St, Sumas, WA 98295 U.S. Mailing Address: P.O. Box 231, Sumas, WA 98295

Phone: 604-853-6096 | Fax: 604-853-8749 | Internet: www.bd-power.com

12. When lowering the valve body, gently work it around so that the park rod lever is left in the transmission and ensure that the electrical plug is not damaged in the removal process.

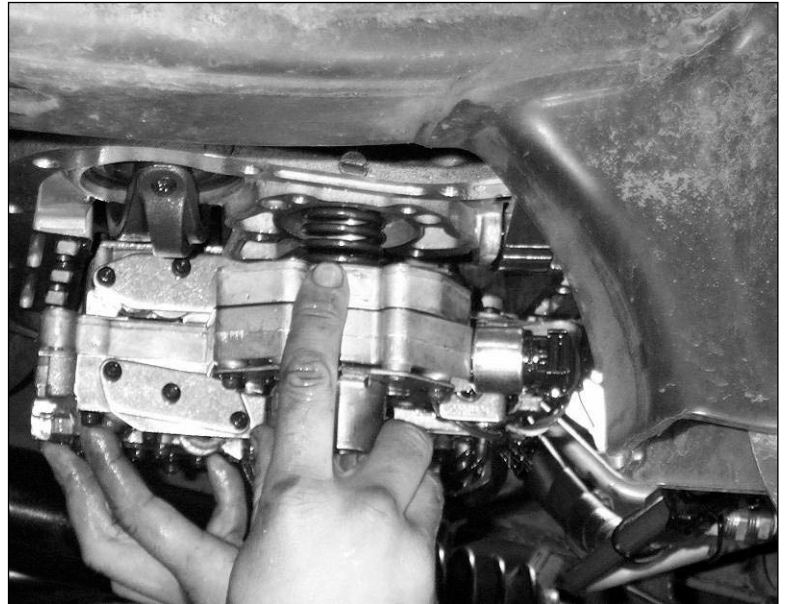

13. **CAUTION** - As you lower the valve body, watch for the accumulator piston and spring falling out. Which is located above the governor solenoid housing.

14. This is the time to change the 2nd gear band strut to the heavy duty one and install the additional 2nd gear servo spring we supply. First loosen the band adjusting screw lock nut with a 3/4" wrench, and then unscrew the adjuster until the stock strut can be removed.

15. For the next step of the instructions you will need a 6" C Clamp. This 6" C clamp is available from Autozone (#QRCC6) or from Schucks / O'Reilly's (#648641).



The cost on this part is roughly \$10.

16. Using a 6" 'C' Clamp and a 1 5/16" socket (or 32mm), depress servo piston guide into bore of the transmission. *This is a critical step and damage could ruin the transmission.*

DO NOT LET ANYTHING SCORE THE BORE OR THE SHAFT.



17. Remove retaining clip. DO NOT LOSE.

18. Loosen C clamp to allow servo piston guide to be removed from bore. Remove clamp, servo piston guide and spring.



19. Add newly supplied spring to back of servo piston guide, along with the original.

20. Re-install servo piston guide into bore with both springs. Hold the servo piston guide in place while slowly tightening the C clamp.

Tighten C clamp very slowly up until the servo piston guide ring touches the bore taper.

Help servo piston guide ring into bore with a small blunt screw driver. **DO NOT DAMAGE SERVO PISTON GUIDE RING.**

If servo piston guide ring binds or catches retaining ring groove lightly tap the servo piston guide to release it.



21. Once servo piston guide is depressed far enough you then can install the retaining ring. Once installed you can remove the C clamp.

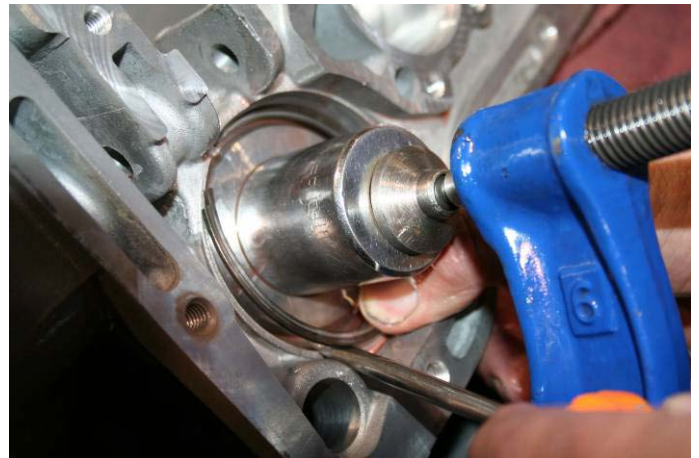



Stock Band Strut in place



New BD Band Strut in place

22. Install the new BD strut with tapered side down, towards the pan, and center in the guides. Torque the band adjustment to 72 inch-lbs, then back out 2 1/4 turns and tighten lock nut. The measurement for the air gap between the band lever and servo piston is 5/16".

NOTE – it is recommended that a new gov. solenoid & pressure transducer be installed at this time.

INSERTING THE DIODE INTO THE VALVE BODY

Cut the Pin #4 sensor ground wire (pink wire) and Pin #3 sensor signal wire (green wire) on the valve body wiring harness and slide the heat shrink tube over one side to seal the connection once completed.

Strip wire ends and install the diode with supplied butt connectors as shown.

**Important* ensure the black stripe on the diode goes towards Pin #4 sensor signal wire (pink wire).*

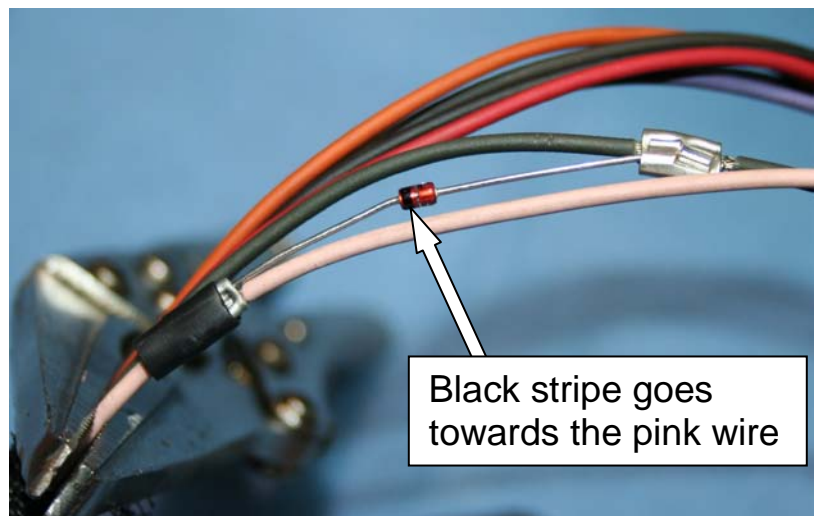

Crimp the butt connectors into place and solder to ensure a good connection.

Move the heat shrink over the connection and apply heat to seal the connection.

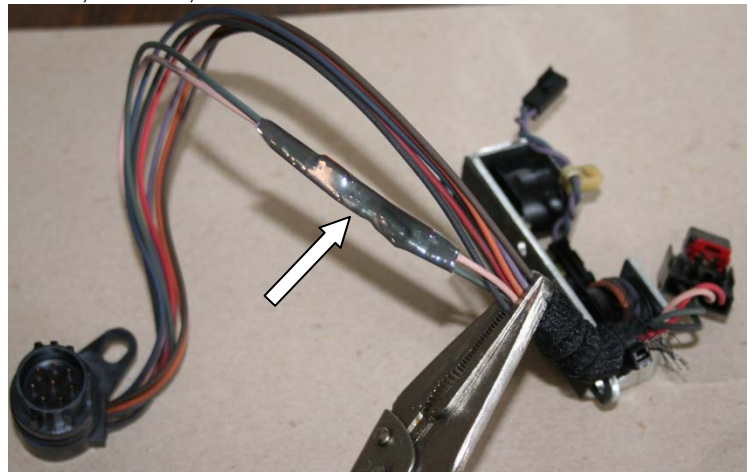

VERY IMPORTANT

A modification needs to be made to the pressure transducer switch (the black plastic style switch) for the 2000-2007 model year trucks, before it is installed on the valve body.

To prevent over pressure damage to the transducer, it will need to have a .040 orifice cup plug installed as shown in the illustration. The best method to insert the orifice cup plug is to squeeze it in gently with a vice. (DO NOT USE A HAMMER).

Once installed the orifice cup plug should be flush.

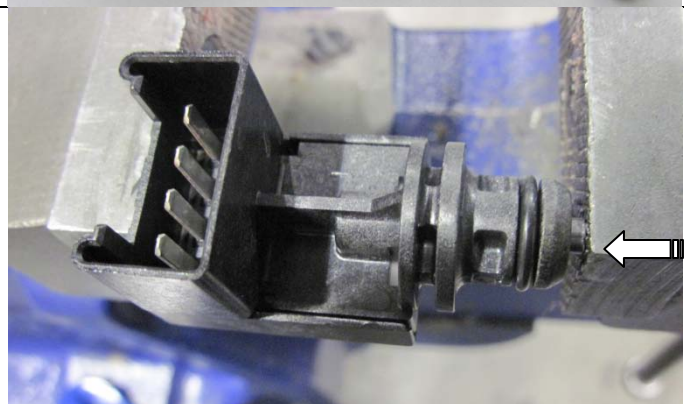
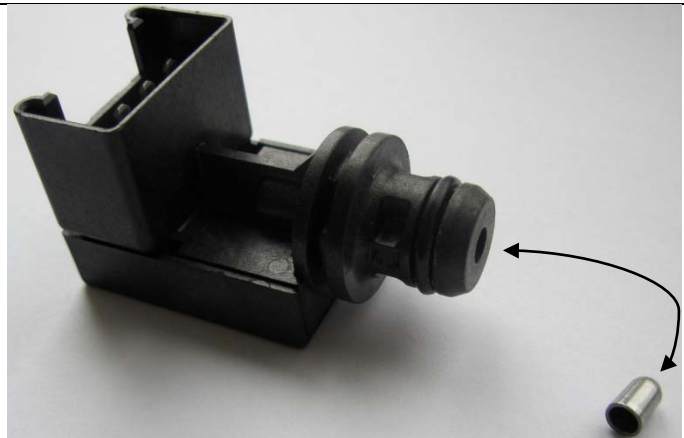

23. **IMPORTANT** - Before installing the BD Valve Body, lubricate the manual-shifting shaft and the O-ring on the electrical connector that fits into the transmission case. Rotate the shift lever all the way forward to place the valve body into 1st / Low gear position so that the park rod and E-clip can be attached later.

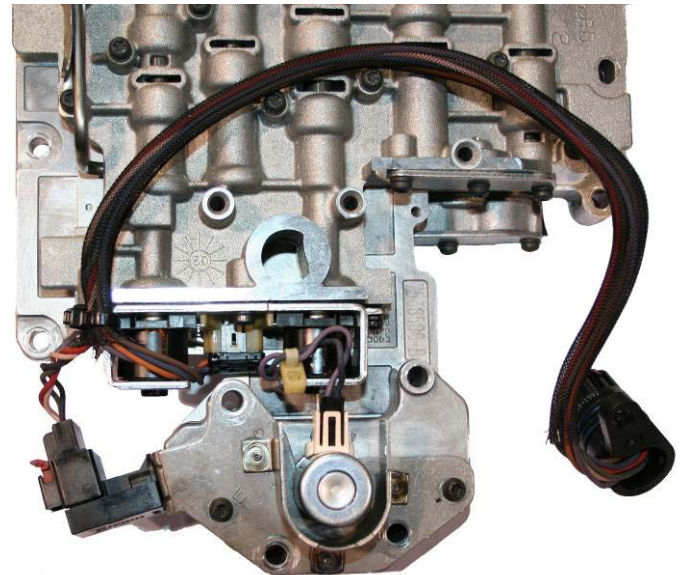
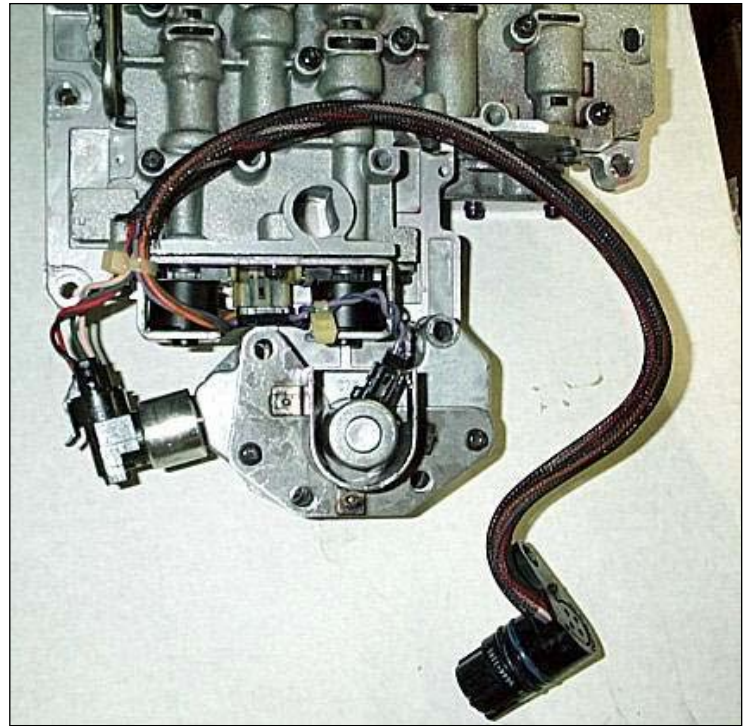

24. Place the accumulator piston and spring into the BD Valve Body. If you cannot balance these parts on the valve body, hold them in place with a supporting tool or wire until the Valve Body is installed.

25. Once the valve body is in position, insert

BD Engine Brake Inc.

Plant Address: 33541 MacLure Rd. Abbotsford, BC, Canada V2S 7W2

U.S. Shipping Address: 88-446 Harrison St, Sumas, WA 98295 U.S. Mailing Address: P.O. Box 231, Sumas, WA 98295

Phone: 604-853-6096 | Fax: 604-853-8749 | Internet: www.bd-power.com

the park rod into the manual shift lever and hold the valve body in place with a couple of bolts.

26. Install the E-clip on the park rod using the flat, slotted end of the Canadian micro-hockey stick.



“Hockey Stick” Tool



27. Install the valve body mounting bolts, ensuring that the varying length bolts are installed into the proper positions, and then torque evenly to 10 lbs-ft.
28. Install the manual lever on the outside of the transmission and check for full movement of the detent shift. There must be 5 distinct positions that are felt from Low (1st) to Park. Leave the transmission in the neutral position and tighten the retaining bolt. Re-install the kick down lever and spring.

BD Engine Brake Inc.

Plant Address: 33541 MacLure Rd. Abbotsford, BC, Canada V2S 7W2

U.S. Shipping Address: 88-446 Harrison St, Sumas, WA 98295 U.S. Mailing Address: P.O. Box 231, Sumas, WA 98295

Phone: 604-853-6096 | Fax: 604-853-8749 | Internet: www.bd-power.com

29. Install the neutral safety switch. The reverse lights at the rear of vehicle should illuminate when the shift lever is in the reverse position (key on).

30. Install the new supplied filter on the valve body.

31. We suggest that you install a BD HD oil pan, which has extra oil capacity, cooling fins, a magnetic drain plug, and adds strength to the transmission case to prevent flexing.

32. Install the shift linkage to the manual lever on the transmission be sure manual shift linkage is adjusted correctly. The kick-down cable can now be attached to the ball socket. Ensure that the wiring harness has some dielectric grease on it and connect it. Ensure not to bend the pins when attaching the plug.

33. When just the valve body is being replaced, the transmission will need ~8-9 quarts of ATF+4. When both the valve body and torque converter are being replaced, ~15-17 quarts are required. **IMPORTANT:** After 8 quarts have been added, start the engine and shift through all gears, and then check the transmission oil level with the shifter in neutral. Top up and check as required. **DO NOT OVERFILL!**

34. After your test drive, check the oil levels again. Air locks are common in this transmission.

35. Road test the vehicle to verify pressures and to check for the wide-open shift points to ensure that they are correct.

These pressures will vary according to the position of the kick down cable adjustment. Engine RPM DOES NOT affect line pressure.

CAUTION – PRESSURE SETTINGS THAT ARE TOO HIGH CAN RESULT IN SEVERE SHIFTS, LIMP MODE, or 2ND OR 3RD GEAR STARTS.

BD Engine Brake Inc.

Plant Address: 33541 MacLure Rd. Abbotsford, BC, Canada V2S 7W2

U.S. Shipping Address: 88-446 Harrison St, Sumas, WA 98295 U.S. Mailing Address: P.O. Box 231, Sumas, WA 98295

Phone: 604-853-6096 | Fax: 604-853-8749 | Internet: www.bd-power.com

Kick Down Cable Adjustment

The adjustment of the kick down cable is one of the most critical adjustments that affect the operation of the transmission.

The BD Performance Valve Body is not stock, therefore the factory specifications for this adjustment are used only as a guide.

Your drivability and performance demands will determine your shift points and pressure adjustments.

Kick down cable adjustments are for Full Throttle shift points & passing gear only. Light throttle shift points should be adjusted on the valve body throttle valve stop.



The kick down cable is located underneath the plastic cover as indicated above.

The plastic cover is held in place by 2 plastic Phillips head screws. Only light pressure is required to remove them. Do not lose the screws or washers when you remove them.

BD Engine Brake Inc.

Plant Address: 33541 MacLure Rd. Abbotsford, BC, Canada V2S 7W2

U.S. Shipping Address: 88-446 Harrison St, Sumas, WA 98295 U.S. Mailing Address: P.O. Box 231, Sumas, WA 98295

Phone: 604-853-6096 | Fax: 604-853-8749 | Internet: www.bd-power.com

Adjust cable so the kickdown lever is pulled all the way back, to it's furthest travel, at wide open throttle. Check this with engine off & pushing throttle pedal to floor.

Adjust the cable forward (towards the radiator), to make the transmission shift earlier.

Adjust the cable back to the rear (towards the firewall), to make the transmission shift later.

Install the plastic cover when complete. Cable should be set midway or with an 1/8" of deflection. Any further adjustment can be made from the starting point.

BD Engine Brake Inc.

Plant Address: 33541 MacLure Rd. Abbotsford, BC, Canada V2S 7W2

U.S. Shipping Address: 88-446 Harrison St, Sumas, WA 98295 U.S. Mailing Address: P.O. Box 231, Sumas, WA 98295

Phone: 604-853-6096 | Fax: 604-853-8749 | Internet: www.bd-power.com

Gear Shift Cable Adjustment – Very Important 48re 2003-2007

ADJUSTMENTS - GEARSHIFT CABLE THIS MUST BE DONE!!

Check adjustment by starting the engine in PARK and NEUTRAL. Adjustment is CORRECT if the engine starts only in these positions. Adjustment is INCORRECT if the engine starts in one but not both positions. If the engine starts in any position other than PARK or NEUTRAL, or if the engine will not start at all, the transmission range sensor may be faulty.

Gearshift Adjustment Procedure

1. Shift transmission into PARK.
2. Release cable adjuster lock tab (3) (underneath the steering column) to unlock cable.
3. Raise vehicle.
4. Disengage the cable eyelet from the transmission manual shift lever.
5. Verify transmission shift lever is in PARK detent by moving lever fully rearward. Last rearward detent is PARK position.
6. Verify positive engagement of transmission park lock by attempting to rotate propeller shaft. Shaft will not rotate when park lock is engaged.
7. Snap the cable eyelet onto the transmission manual shift lever.
8. Lower vehicle.
9. Lock shift cable by pressing cable adjuster lock tab (3) downward until it snaps into place.
10. Check engine starting. Engine should start only in PARK and NEUTRAL.

BD Engine Brake Inc.

Plant Address: 33541 MacLure Rd. Abbotsford, BC, Canada V2S 7W2

U.S. Shipping Address: 88-446 Harrison St, Sumas, WA 98295 U.S. Mailing Address: P.O. Box 231, Sumas, WA 98295

Phone: 604-853-6096 | Fax: 604-853-8749 | Internet: www.bd-power.com

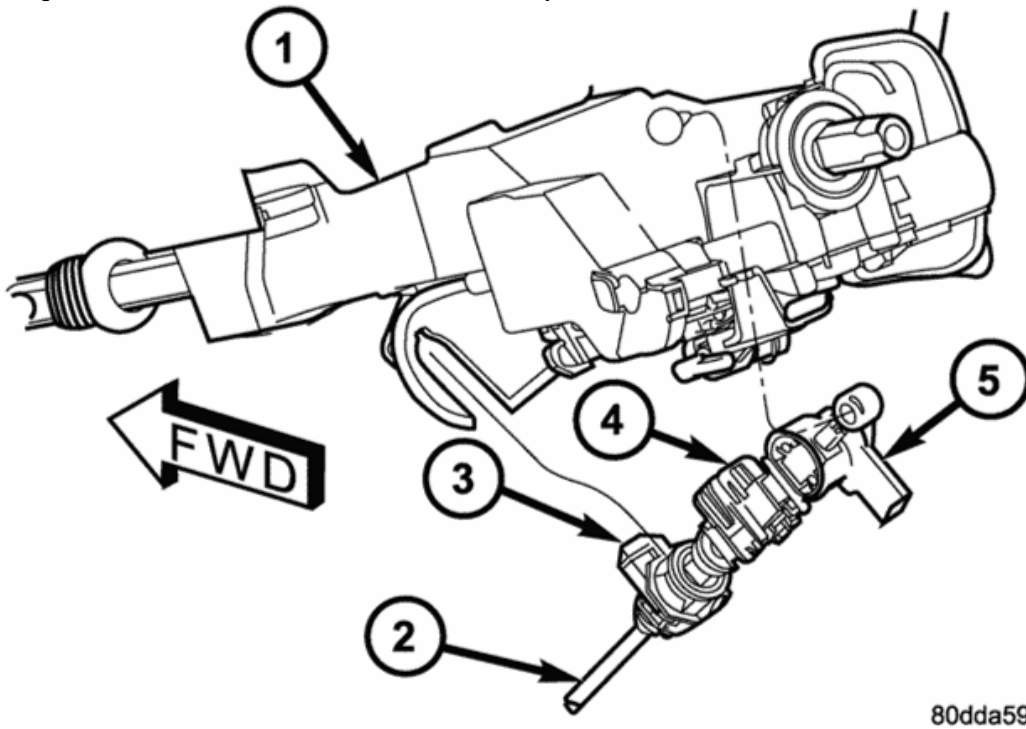

1 - STEERING COLUMN
2 - GEARSHIFT CABLE
3 - GEARSHIFT CABLE LOCK TAB
4 - BTSI SOLENOID LOCK TAB
5 - BTSI CONNECTOR

BD Engine Brake Inc.

Plant Address: 33541 MacLure Rd. Abbotsford, BC, Canada V2S 7W2

U.S. Shipping Address: 88-446 Harrison St, Sumas, WA 98295 U.S. Mailing Address: P.O. Box 231, Sumas, WA 98295

Phone: 604-853-6096 | Fax: 604-853-8749 | Internet: www.bd-power.com

Questions?

If you require assistance with this kit, please call our Transmission Technical Support Line at (800) 887-5030, Monday to Friday from 8:00-4:00pm Pacific Standard Time (PST). As an alternative, you can post a support question on our technical forum, located at <http://www.bd-power.com/forum/> .



BD Engine Brake Inc.

Plant Address: 33541 MacLure Rd. Abbotsford, BC, Canada V2S 7W2

U.S. Shipping Address: 88-446 Harrison St, Sumas, WA 98295 U.S. Mailing Address: P.O. Box 231, Sumas, WA 98295

Phone: 604-853-6096 | Fax: 604-853-8749 | Internet: www.bd-power.com